

Request For Quotation

Order the parts you need from our real-time inventory database. Simply complete a request for quotation form with your part information and a sales representative will respond to you with price and availability.

[Request For Quotation](#)

Your free datasheet starts on the next page.

More datasheets and data books are available from our homepage: <http://www.datasheetarchive.com>



PIC18F1220/1320

Data Sheet

18/20/28-Pin High Performance,
Enhanced FLASH Microcontrollers
with 10-bit A/D and nanoWatt Technology

Note the following details of the code protection feature on PICmicro[®] MCUs.

- The PICmicro family meets the specifications contained in the Microchip Data Sheet.
- Microchip believes that its family of PICmicro microcontrollers is one of the most secure products of its kind on the market today, when used in the intended manner and under normal conditions.
- There are dishonest and possibly illegal methods used to breach the code protection feature. All of these methods, to our knowledge, require using the PICmicro microcontroller in a manner outside the operating specifications contained in the data sheet. The person doing so may be engaged in theft of intellectual property.
- Microchip is willing to work with the customer who is concerned about the integrity of their code.
- Neither Microchip nor any other semiconductor manufacturer can guarantee the security of their code. Code protection does not mean that we are guaranteeing the product as “unbreakable”.
- Code protection is constantly evolving. We at Microchip are committed to continuously improving the code protection features of our product.

If you have any further questions about this matter, please contact the local sales office nearest to you.

Information contained in this publication regarding device applications and the like is intended through suggestion only and may be superseded by updates. It is your responsibility to ensure that your application meets with your specifications. No representation or warranty is given and no liability is assumed by Microchip Technology Incorporated with respect to the accuracy or use of such information, or infringement of patents or other intellectual property rights arising from such use or otherwise. Use of Microchip's products as critical components in life support systems is not authorized except with express written approval by Microchip. No licenses are conveyed, implicitly or otherwise, under any intellectual property rights.

Trademarks

The Microchip name and logo, the Microchip logo, KEELOQ, MPLAB, PIC, PICmicro, PICSTART and PRO MATE are registered trademarks of Microchip Technology Incorporated in the U.S.A. and other countries.

FilterLab, microID, MXDEV, MXLAB, PICMASTER, SEEVAL and The Embedded Control Solutions Company are registered trademarks of Microchip Technology Incorporated in the U.S.A.

dsPIC, dsPICDEM.net, ECONOMONITOR, FanSense, FlexROM, fuzzyLAB, In-Circuit Serial Programming, ICSP, ICEPIC, microPort, Migratable Memory, MPASM, MPLIB, MPLINK, MPSIM, PICC, PICDEM, PICDEM.net, rPIC, Select Mode and Total Endurance are trademarks of Microchip Technology Incorporated in the U.S.A. and other countries.

Serialized Quick Turn Programming (SQTP) is a service mark of Microchip Technology Incorporated in the U.S.A.

All other trademarks mentioned herein are property of their respective companies.

© 2002, Microchip Technology Incorporated, Printed in the U.S.A., All Rights Reserved.

 Printed on recycled paper.

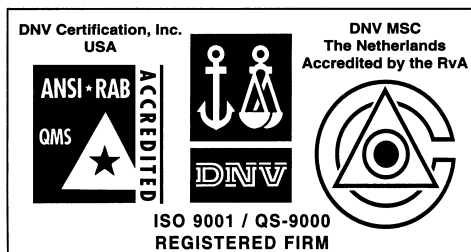

Microchip received QS-9000 quality system certification for its worldwide headquarters, design and wafer fabrication facilities in Chandler and Tempe, Arizona in July 1999 and Mountain View, California in March 2002. The Company's quality system processes and procedures are QS-9000 compliant for its PICmicro[®] 8-bit MCUs, KEELOQ[®] code hopping devices, Serial EEPROMs, microperipherals, non-volatile memory and analog products. In addition, Microchip's quality system for the design and manufacture of development systems is ISO 9001 certified.



MICROCHIP

PIC18F1220/1320

18/20/28-Pin High Performance, Enhanced FLASH MCUs with 10-bit A/D and nanoWatt Technology

Low Power Features:

- Power Managed modes:
 - RUN CPU on, peripherals on
 - IDLE CPU off, peripherals on
 - SLEEP CPU off, peripherals off
- Power Consumption modes:
 - PRI_RUN 150 μ A, 1 MHz, 2V
 - PRI_IDLE 37 μ A, 1 MHz, 2V
 - SEC_RUN 14 μ A, 32 kHz, 2V
 - SEC_IDLE 5.8 μ A, 32 kHz, 2V
 - RC_RUN 110 μ A, 1 MHz, 2V
 - RC_IDLE 52 μ A, 1 MHz, 2V
 - SLEEP 0.1 μ A, 1 MHz, 2V
- Timer1 oscillator 1.1 μ A, 32 kHz, 2V
- Watchdog Timer 2.1 μ A
- Two-speed Oscillator Start-up

Oscillators:

- Four Crystal modes:
 - LP, XT, HS up to 25 MHz
 - HSPLL 4 - 10 MHz (16 - 40 MHz internal)
- Two External RC modes, up to 4 MHz
- Two External Clock modes, up to 40 MHz
- Internal oscillator block:
 - 8 user selectable frequencies: 31 kHz, 125 kHz, 250 kHz, 500 kHz, 1 MHz, 2 MHz, 4 MHz, 8 MHz
 - 125 kHz - 8 MHz calibrated to 1%
 - Two modes select one or two I/O pins
 - OSCTUNE - Allows user to shift frequency
- Secondary oscillator using Timer1 @ 32 kHz
- Fail-Safe Clock Monitor
 - Allows for safe shutdown if peripheral clock stops

Peripheral Highlights:

- High current sink/source 25 mA/25 mA
- Three external interrupts
- Enhanced Capture/Compare/PWM (ECCP) module:
 - One, two, or four PWM outputs
 - Selectable polarity
 - Programmable dead-time
 - Auto shutdown and auto restart
 - Capture is 16-bit, max resolution 6.25 ns (T_{cy}/16)
 - Compare is 16-bit, max resolution 100 ns (T_{cy})
- Compatible 10-bit, up to 13-channel Analog-to-Digital Converter module (A/D) with programmable acquisition time
- Dual analog comparators
- Enhanced USART module:
 - Supports RS-485, RS-232, and LIN 1.2
 - Auto wake-up on START bit
 - Auto baud detect

Special Microcontroller Features:

- 100,000 erase/write cycle Enhanced FLASH program memory typical
- 1,000,000 erase/write cycle Data EEPROM memory typical
- FLASH/Data EEPROM Retention: > 40 years
- Self-programmable under software control
- Priority levels for interrupts
- 8 X 8 Single Cycle Hardware Multiplier
- Extended Watchdog Timer (WDT):
 - Programmable period from 41 ms to 131s
 - 2% stability over V_{DD} and Temperature
- Single supply 5V In-Circuit Serial Programming™ (ICSP™) via two pins
- In-Circuit Debug (ICD) via two pins
- Wide operating voltage range: 2.0V to 5.5V

Device	Program Memory		Data Memory		I/O	10-bit A/D (ch)	ECCP (PWM)	EUSART	Comparators	Timers 8/16-bit
	FLASH (bytes)	# Single Word Instructions	SRAM (bytes)	EEPROM (bytes)						
PIC18F1220	4K	2048	256	256	16	7	1	Y	2	1/3
PIC18F1320	8K	4096	256	256	16	7	1	Y	2	1/3

PIC18F1220/1320

Pin Diagrams

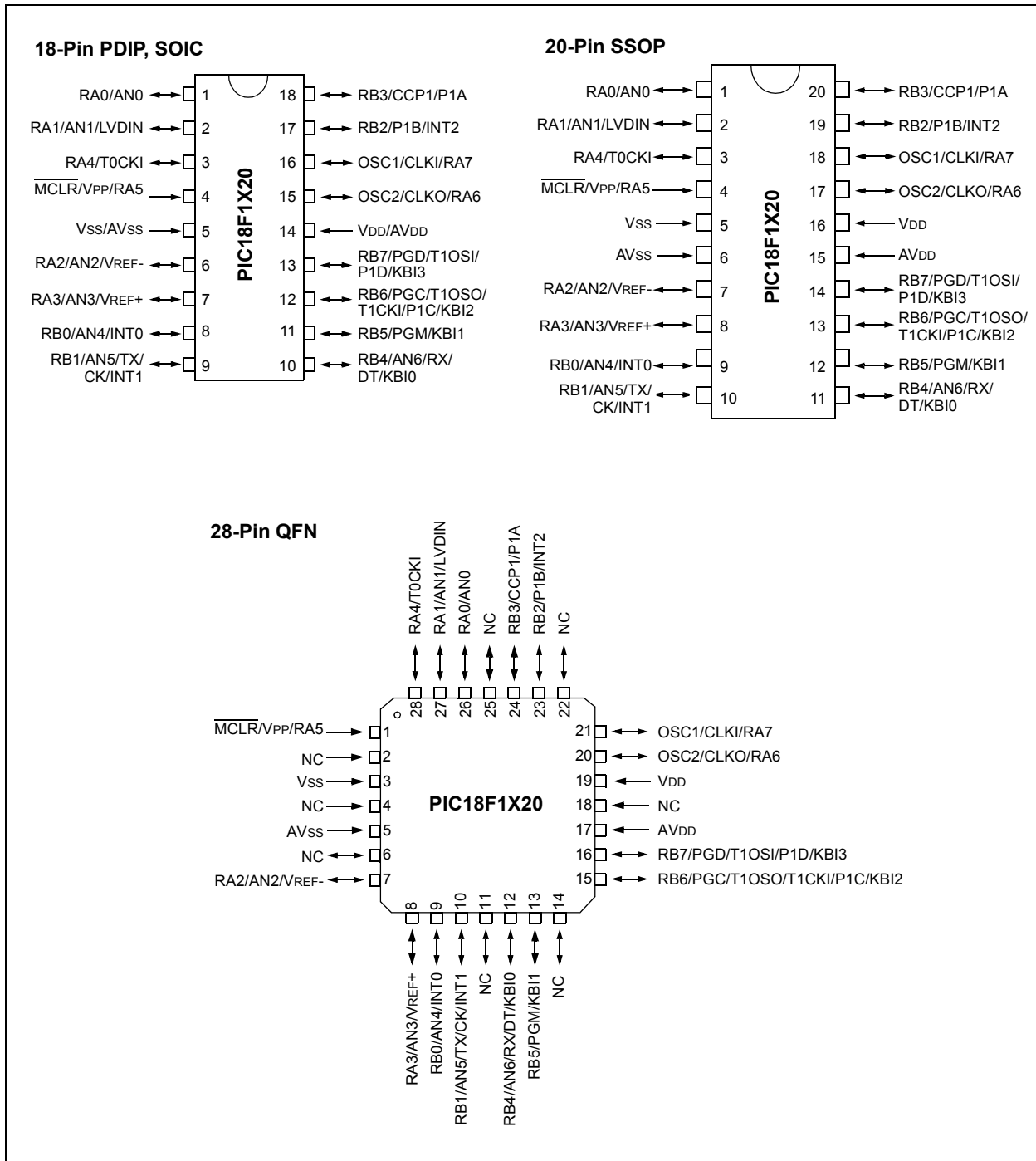

Table of Contents

1.0	Device Overview	5
2.0	Oscillator Configurations	11
3.0	Power Managed Modes	19
4.0	Reset	33
5.0	Memory Organization	43
6.0	FLASH Program Memory	59
7.0	Data EEPROM Memory	69
8.0	8 X 8 Hardware Multiplier	73
9.0	Interrupts	75
10.0	I/O Ports	89
11.0	Timer0 Module	101
12.0	Timer1 Module	105
13.0	Timer2 Module	111
14.0	Timer3 Module	113
15.0	Enhanced Capture/Compare/PWM (ECCP) Module.....	117
16.0	Enhanced Universal Synchronous Asynchronous Receiver Transmitter (USART)	133
17.0	10-bit Analog-to-Digital Converter (A/D) Module.....	155
18.0	Low Voltage Detect	165
19.0	Special Features of the CPU.....	171
20.0	Instruction Set Summary	189
21.0	Development Support.....	231
22.0	Electrical Characteristics	237
23.0	Preliminary DC and AC Characteristics Graphs and Tables.....	263
24.0	Packaging Information.....	267
Appendix A: Revision History.....		273
Appendix B: Device Differences		273
Appendix C: Conversion Considerations		274
Appendix D: Migration from Baseline to Enhanced Devices.....		274
Appendix E: Migration from Mid-range to Enhanced Devices		275
Appendix F: Migration from High-end to Enhanced Devices		275
Index		277
On-Line Support.....		285
Systems Information and Upgrade Hot Line		285
Reader Response		286
PIC18F1220/1320 Product Identification System		287

TO OUR VALUED CUSTOMERS

It is our intention to provide our valued customers with the best documentation possible to ensure successful use of your Microchip products. To this end, we will continue to improve our publications to better suit your needs. Our publications will be refined and enhanced as new volumes and updates are introduced.

If you have any questions or comments regarding this publication, please contact the Marketing Communications Department via E-mail at docerrors@mail.microchip.com or fax the **Reader Response Form** in the back of this data sheet to (480) 792-4150. We welcome your feedback.

Most Current Data Sheet

To obtain the most up-to-date version of this data sheet, please register at our Worldwide Web site at:

<http://www.microchip.com>

You can determine the version of a data sheet by examining its literature number found on the bottom outside corner of any page. The last character of the literature number is the version number, (e.g., DS30000A is version A of document DS30000).

Errata

An errata sheet, describing minor operational differences from the data sheet and recommended workarounds, may exist for current devices. As device/documentation issues become known to us, we will publish an errata sheet. The errata will specify the revision of silicon and revision of document to which it applies.

To determine if an errata sheet exists for a particular device, please check with one of the following:

- Microchip's Worldwide Web site; <http://www.microchip.com>
- Your local Microchip sales office (see last page)
- The Microchip Corporate Literature Center; U.S. FAX: (480) 792-7277

When contacting a sales office or the literature center, please specify which device, revision of silicon and data sheet (include literature number) you are using.

Customer Notification System

Register on our web site at www.microchip.com/cn to receive the most current information on all of our products.

1.0 DEVICE OVERVIEW

This document contains device specific information for the following devices:

- PIC18F1220
- PIC18F1320

This family offers the advantages of all PIC18 micro-controllers – namely, high computational performance at an economical price – with the addition of high endurance Enhanced FLASH program memory. On top of these features, the PIC18F1220/1320 family introduces design enhancements that make these micro-controllers a logical choice for many high performance, power sensitive applications.

1.1 New Core Features

1.1.1 NANOWATT TECHNOLOGY

All of the devices in the PIC18F1220/1320 family incorporate a range of features that can significantly reduce power consumption during operation. Key items include:

- **Alternate RUN Modes:** By clocking the controller from the Timer1 source or the Internal Oscillator block, power consumption during code execution can be reduced by as much as 90%.
- **Multiple IDLE Modes:** The controller can also run with its CPU core disabled, but the peripherals still active. In these states, power consumption can be reduced even further, to as little as 4% of normal operation requirements.
- **On-the-fly Mode Switching:** The Power Managed modes are invoked by user code during operation, allowing the user to incorporate power saving ideas into their application's software design.
- **Lower Consumption in Key Modules:** The power requirements for both Timer1 and the Watchdog Timer have been reduced by up to 80%, with typical values of 1.1 and 2.1 μ A, respectively.

1.1.2 MULTIPLE OSCILLATOR OPTIONS AND FEATURES

All of the devices in the PIC18F1220/1320 family offer nine different oscillator options, allowing the users a wide range of choices in developing application hardware. These include:

- Four Crystal modes, using crystals or ceramic resonators.
- Two External Clock modes, offering the option of using two pins (oscillator input and a divide-by-4 clock output), or one pin (oscillator input, with the second pin re-assigned as general I/O).
- Two external RC Oscillator modes, with the same pin options as the External Clock modes.
- An internal oscillator block which provides an 8 MHz clock ($\pm 2\%$ accuracy) and an INTRC source (approximately 31 kHz, stable over temperature and VDD), as well as a range of 6 user selectable clock frequencies (from 125 kHz to 4 MHz) for a total of 8 clock frequencies.

Besides its availability as a clock source, the internal oscillator block provides a stable reference source that gives the family additional features for robust operation:

- **Fail-Safe Clock Monitor:** This option constantly monitors the main clock source against a reference signal provided by the internal oscillator. If a clock failure occurs, the controller is switched to the internal oscillator block, allowing for continued low speed operation, or a safe application shutdown.
- **Two-Speed Start-up:** This option allows the internal oscillator to serve as the clock source from Power-on Reset, or wake-up from SLEEP mode, until the primary clock source is available. This allows for code execution during what would otherwise be the clock start-up interval, and can even allow an application to perform routine background activities and return to SLEEP without returning to full power operation.

1.2 Other Special Features

- **Memory Endurance:** The Enhanced FLASH cells for both program memory and data EEPROM are rated to last for many thousands of erase/write cycles – up to 100,000 for program memory and 1,000,000 for EEPROM. Data retention without refresh is conservatively estimated to be greater than 40 years.
- **Self-programmability:** These devices can write to their own program memory spaces under internal software control. By using a bootloader routine located in the protected Boot Block at the top of program memory, it becomes possible to create an application that can update itself in the field.
- **Enhanced CCP module:** In PWM mode, this module provides 1, 2 or 4 modulated outputs for controlling half-bridge and full-bridge drivers. Other features include Auto Shutdown, for disabling PWM outputs on interrupt or other select conditions, and Auto Restart, to re-activate outputs once the condition has cleared.
- **Enhanced USART:** This serial communication module features automatic wake-up on START bit and automatic baud rate detection, and supports RS-232, RS-485, and LIN 1.2 protocols, making it ideally suited for use in Local Interconnect Network (LIN) bus applications.
- **10-bit A/D Converter:** This module incorporates Programmable Acquisition Time, allowing for a channel to be selected and a conversion to be initiated without waiting for a sampling period and thus, reduce code overhead.
- **Extended Watchdog Timer (WDT):** This enhanced version incorporates a 16-bit prescaler, allowing a time-out range from 4 ms to over 2 minutes, that is stable across operating voltage and temperature.

PIC18F1220/1320

1.3 Details on Individual Family Members

Devices in the PIC18F1220/1320 family are available in 18-pin, 20-pin, and 28-pin packages. A block diagram for this device family is shown in Figure 1-1.

The devices are differentiated from each other only in the amount of on-chip FLASH program memory (4 Kbytes for the PIC18F1220 device, 8 Kbytes for PIC18F1320). These and other features are summarized in Table 1-1.

A block diagram of the PIC18F1220/1320 device architecture is provided in Figure 1-1. The pinouts for this device family are listed in Table 1-2.

TABLE 1-1: DEVICE FEATURES

Features	PIC18F1220	PIC18F1320
Operating Frequency	DC - 40 MHz	DC - 40 MHz
Program Memory (Bytes)	4096	8192
Program Memory (Instructions)	2048	4096
Data Memory (Bytes)	256	256
Data EEPROM Memory (Bytes)	256	256
Interrupt Sources	15	15
I/O Ports	Ports A, B	Ports A, B
Timers	4	4
Enhanced Capture/Compare/PWM Modules	1	1
Serial Communications	Enhanced USART	Enhanced USART
10-bit Analog-to-Digital Module	7 input channels	7 input channels
RESETS (and Delays)	POR, BOR, RESET Instruction, Stack Full, Stack Underflow (PWRT, OST), MCLR (optional), WDT	POR, BOR, RESET Instruction, Stack Full, Stack Underflow (PWRT, OST), MCLR (optional), WDT
Programmable Low Voltage Detect	Yes	Yes
Programmable Brown-out Reset	Yes	Yes
Instruction Set	75 Instructions	75 Instructions
Packages	18-pin SDIP 18-pin SOIC 20-pin SSOP 28-pin QFN	18-pin SDIP 18-pin SOIC 20-pin SSOP 28-pin QFN

PIC18F1220/1320

FIGURE 1-1: PIC18F1220/1320 BLOCK DIAGRAM

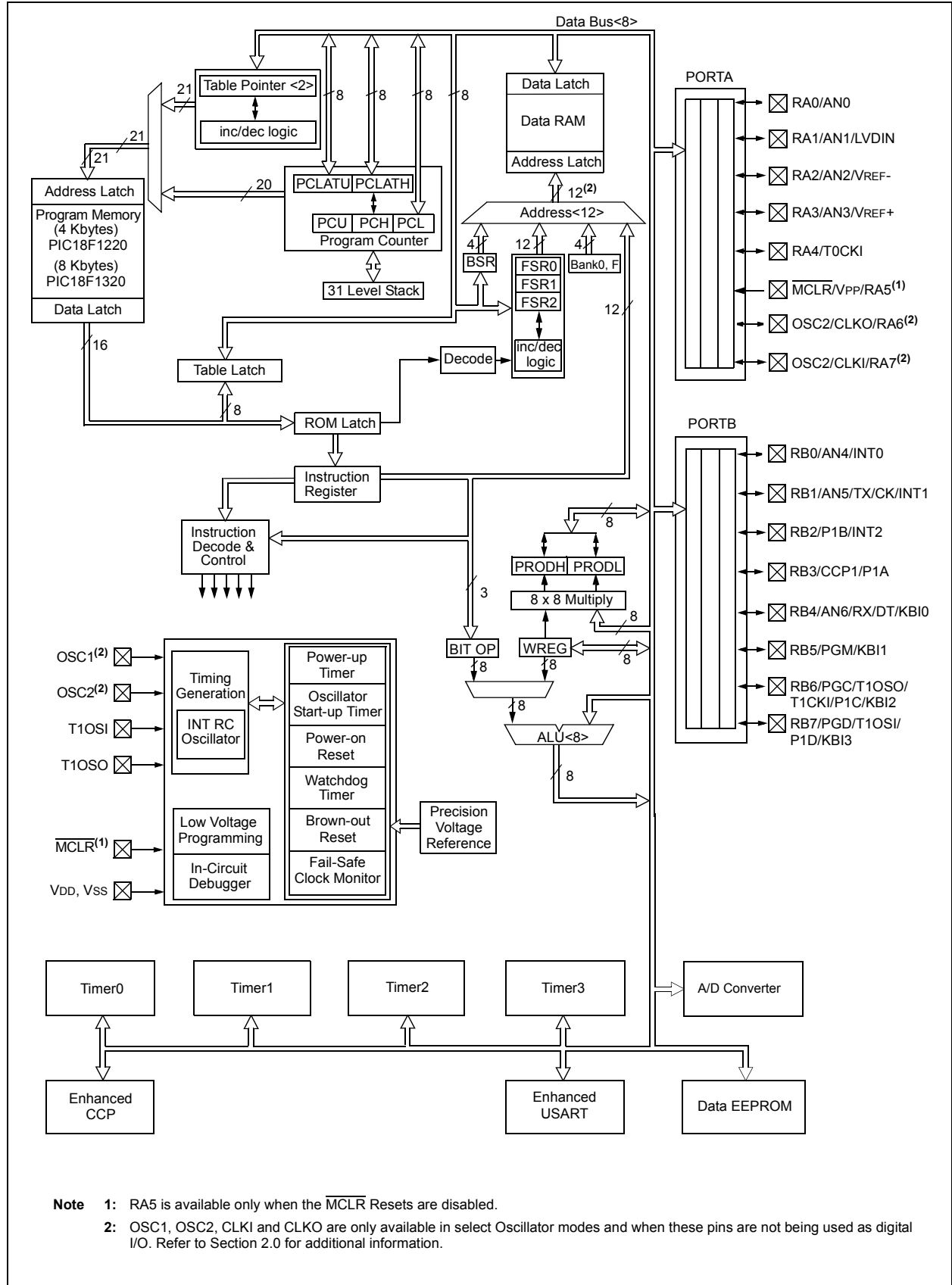

PIC18F1220/1320

TABLE 1-2: PIC18F1220/1320 PINOUT I/O DESCRIPTIONS

Pin Name	Pin Number			Pin Type	Buffer Type	Description
	PDIP/ SOIC	SSOP	QFN			
MCLR/VPP/RA5 MCLR	4	4	1	I	ST	Master Clear (input) or programming voltage (input). Master Clear (Reset) input. This pin is an active low RESET to the device.
VPP				P	—	Programming voltage input.
RA5				I	ST	Digital input.
OSC1/CLKI/RA7 OSC1	16	18	21	I	ST	Oscillator crystal or external clock input. Oscillator crystal input or external clock source input. ST buffer when configured in RC mode, CMOS otherwise.
CLKI				I	CMOS	External clock source input. Always associated with pin function OSC1. (See related OSC1/CLKI, OSC2/CLKO pins.)
RA7				I/O	ST	General purpose I/O pin.
OSC2/CLKO/RA6 OSC2	15	17	20	O	—	Oscillator crystal or clock output. Oscillator crystal output. Connects to crystal or resonator in Crystal Oscillator mode.
CLKO				O	—	In RC, EC and INTRC modes, OSC2 pin outputs CLKO, which has 1/4 the frequency of OSC1 and denotes instruction cycle rate.
RA6				I/O	ST	General purpose I/O pin.
RA0/AN0 RA0 AN0	1	1	26	I/O I	ST Analog	PORTA is a bi-directional I/O port. Digital I/O. Analog input 0.
RA1/AN1/LVDIN RA1 AN1 LVDIN	2	2	27	I/O I I	ST Analog Analog	Digital I/O. Analog input 1. Low Voltage Detect input.
RA2/AN2/VREF- RA2 AN2 VREF-	6	7	7	I/O I I	ST Analog Analog	Digital I/O. Analog input 2. A/D Reference Voltage (Low) input.
RA3/AN3/VREF+ RA3 AN3 VREF+	7	8	8	I/O I I	ST Analog Analog	Digital I/O. Analog input 3. A/D Reference Voltage (High) input.
RA4/T0CKI RA4 T0CKI	3	3	28	I/O I	ST/OD ST	Digital I/O. Open drain when configured as output. Timer0 external clock input.
RA5						See the MCLR/VPP/RA5 pin.
RA6						See the OSC2/CLKO/RA6 pin.
RA7						See the OSC1/CLKI/RA7 pin.

Legend: TTL = TTL compatible input

ST = Schmitt Trigger input with CMOS levels

O = Output

OD = Open Drain (no P diode to VDD)

CMOS = CMOS compatible input or output

I = Input

P = Power

PIC18F1220/1320

TABLE 1-2: PIC18F1220/1320 PINOUT I/O DESCRIPTIONS (CONTINUED)

Pin Name	Pin Number			Pin Type	Buffer Type	Description
	PDIP/ SOIC	SSOP	QFN			
RB0/AN4/INT0 RB0 AN4 INT0	8	9	9	I/O I I	TTL Analog ST	PORTB is a bi-directional I/O port. PORTB can be software programmed for internal weak pull-ups on all inputs. Digital I/O. Analog input 4. External interrupt 0.
RB1/AN5/TX/CK/INT1 RB1 AN5 TX CK INT1	9	10	10	I/O I O I/O I	TTL Analog — ST ST	Digital I/O. Analog input 5. USART Asynchronous Transmit USART Synchronous Clock (see related RX/DT). External interrupt 1.
RB2/P1B/INT2 RB2 P1B INT2	17	19	23	I/O O I	TTL — ST	Digital I/O. Enhanced CCP1 output. External interrupt 2.
RB3/CCP1/P1A RB3 CCP1 P1A	18	20	24	I/O I/O O	TTL ST —	Digital I/O. Capture1 input, Compare1 output, PWM1 output. Enhanced CCP1 output.
RB4/AN6/RX/DT/KBI0 RB4 AN6 RX DT KBI0	10	11	12	I/O I I I/O I	TTL Analog ST ST TTL	Digital I/O. Analog input 6. USART Asynchronous Receive. USART Synchronous Data (see related TX/CK). Interrupt-on-change pin.
RB5/PGM/KBI1 RB5 PGM KBI1	11	12	13	I/O I/O I	TTL ST TTL	Digital I/O. Low Voltage ICSP programming enable pin. Interrupt-on-change pin.
RB6/PGC/T1OSO/ T1CKI/P1C/KBI2 RB6 PGC T1OSO T1CKI P1C KBI2	12	13	15	I/O I/O O I O I	TTL ST — ST — TTL	Digital I/O. In-Circuit Debugger and ICSP programming clock pin. Timer1 oscillator output. Timer1 external clock output. Enhanced CCP1 output. Interrupt-on-change pin.
RB7/PGD/T1OSI/ P1D/KBI3 RB7 PGD T1OSI P1D KBI3	13	14	16	I/O I/O I O I	TTL ST CMOS — TTL	Digital I/O. In-Circuit Debugger and ICSP programming data pin. Timer1 oscillator input. Enhanced CCP1 output. Interrupt-on-change pin.
Vss	5	5, 6	3, 5	P	—	Ground reference for logic and I/O pins.
VDD	14	15, 16	17, 19	P	—	Positive supply for logic and I/O pins.

Legend: TTL = TTL compatible input
 ST = Schmitt Trigger input with CMOS levels
 O = Output
 OD = Open Drain (no P diode to VDD)
 CMOS = CMOS compatible input or output
 I = Input
 P = Power

PIC18F1220/1320

NOTES:

2.0 OSCILLATOR CONFIGURATIONS

2.1 Oscillator Types

The PIC18F1220 and PIC18F1320 devices can be operated in ten different Oscillator modes. The user can program the configuration bits FOSC3:FOSC0 in Configuration Register 1H to select one of these ten modes:

1. LP Low Power Crystal
2. XT Crystal/Resonator
3. HS High Speed Crystal/Resonator
4. HSPLL High Speed Crystal/Resonator with PLL enabled
5. RC External Resistor/Capacitor with Fosc/4 output on RA6
6. RCIO External Resistor/Capacitor with I/O on RA6
7. INTIO1 Internal Oscillator with Fosc/4 output on RA6 and I/O on RA7
8. INTIO2 Internal Oscillator with I/O on RA6 and RA7
9. EC External Clock with Fosc/4 output
10. ECIO External Clock with I/O on RA6

2.2 Crystal Oscillator/Ceramic Resonators

In XT, LP, HS or HSPLL Oscillator modes, a crystal or ceramic resonator is connected to the OSC1 and OSC2 pins to establish oscillation. Figure 2-1 shows the pin connections.

The oscillator design requires the use of a parallel cut crystal.

Note: Use of a series cut crystal may give a frequency out of the crystal manufacturers specifications.

FIGURE 2-1: CRYSTAL/CERAMIC RESONATOR OPERATION (XT, LP, HS OR HSPLL CONFIGURATION)

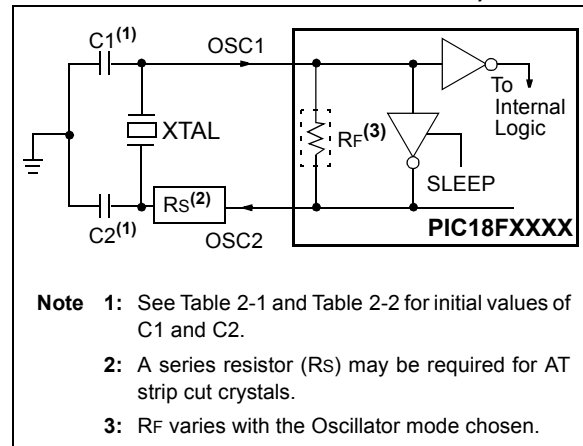

- Note**
- 1: See Table 2-1 and Table 2-2 for initial values of C1 and C2.
 - 2: A series resistor (Rs) may be required for AT strip cut crystals.
 - 3: Rf varies with the Oscillator mode chosen.

TABLE 2-1: CAPACITOR SELECTION FOR CERAMIC RESONATORS

Typical Capacitor Values Used:			
Mode	Freq	OSC1	OSC2
XT	455 kHz	56 pF	56 pF
	2.0 MHz	47 pF	47 pF
	4.0 MHz	33 pF	33 pF
HS	8.0 MHz	27 pF	27 pF
	16.0 MHz	22 pF	22 pF

Capacitor values are for design guidance only.

These capacitors were tested with the resonators listed below for basic start-up and operation. **These values are not optimized.**

Different capacitor values may be required to produce acceptable oscillator operation. The user should test the performance of the oscillator over the expected VDD and temperature range for the application.

See the notes on page 12 for additional information.

Resonators Used:	
455 kHz	4.0 MHz
2.0 MHz	8.0 MHz
16.0 MHz	

PIC18F1220/1320

TABLE 2-2: CAPACITOR SELECTION FOR CRYSTAL OSCILLATOR

Osc Type	Crystal Freq	Typical Capacitor Values Tested:	
		C1	C2
LP	32 kHz	33 pF	33 pF
	200 kHz	15 pF	15 pF
XT	1 MHz	33 pF	33 pF
	4 MHz	27 pF	27 pF
HS	4 MHz	27 pF	27 pF
	8 MHz	22 pF	22 pF
	20 MHz	15 pF	15 pF

Capacitor values are for design guidance only.

These capacitors were tested with the crystals listed below for basic start-up and operation. **These values are not optimized.**

Different capacitor values may be required to produce acceptable oscillator operation. The user should test the performance of the oscillator over the expected VDD and temperature range for the application.

See the notes following this table for additional information.

Crystals Used:

32 kHz	4 MHz
200 kHz	8 MHz
1 MHz	20 MHz

- Note 1:** Higher capacitance increases the stability of oscillator, but also increases the start-up time.
- 2:** When operating below 3V VDD, or when using certain ceramic resonators at any voltage, it may be necessary to use the HS mode or switch to a crystal oscillator.
- 3:** Since each resonator/crystal has its own characteristics, the user should consult the resonator/crystal manufacturer for appropriate values of external components.
- 4:** Rs may be required to avoid overdriving crystals with low drive level specification.
- 5:** Always verify oscillator performance over the VDD and temperature range that is expected for the application.

An external clock source may also be connected to the OSC1 pin in the HS mode, as shown in Figure 2-2.

FIGURE 2-2: EXTERNAL CLOCK INPUT OPERATION (HS OSC CONFIGURATION)

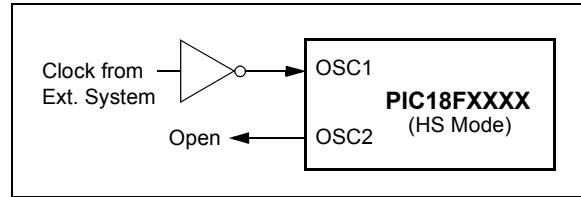

2.3 HSPLL

A Phase Locked Loop (PLL) circuit is provided as an option for users who wish to use a lower frequency crystal oscillator circuit, or to clock the device up to its highest rated frequency from a crystal oscillator. This may be useful for customers who are concerned with EMI due to high frequency crystals.

The HSPLL mode makes use of the HS mode oscillator for frequencies up to 10 MHz. A PLL then multiplies the oscillator output frequency by 4 to produce an internal clock frequency up to 40 MHz.

The PLL is enabled only when the oscillator configuration bits are programmed for HSPLL mode. If programmed for any other mode, the PLL is not enabled.

FIGURE 2-3: PLL BLOCK DIAGRAM

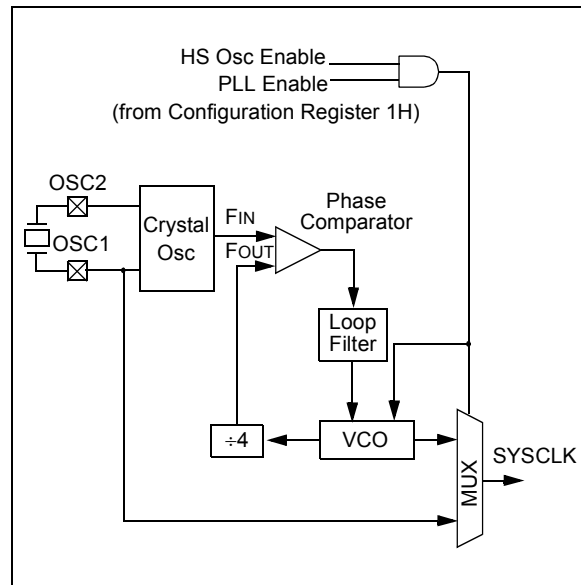

2.4 External Clock Input

The EC and ECIO Oscillator modes require an external clock source to be connected to the OSC1 pin. There is no oscillator start-up time required after a Power-on Reset, or after an exit from SLEEP mode.

In the EC Oscillator mode, the oscillator frequency divided by 4 is available on the OSC2 pin. This signal may be used for test purposes, or to synchronize other logic. Figure 2-4 shows the pin connections for the EC Oscillator mode.

FIGURE 2-4: EXTERNAL CLOCK INPUT OPERATION (EC CONFIGURATION)

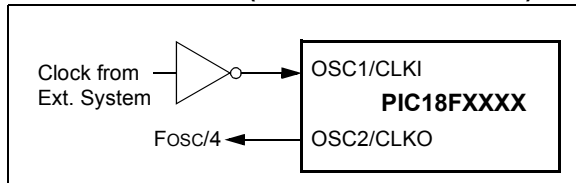

The ECIO Oscillator mode functions like the EC mode, except that the OSC2 pin becomes an additional general purpose I/O pin. The I/O pin becomes bit 6 of PORTA (RA6). Figure 2-5 shows the pin connections for the ECIO Oscillator mode.

FIGURE 2-5: EXTERNAL CLOCK INPUT OPERATION (ECIO CONFIGURATION)

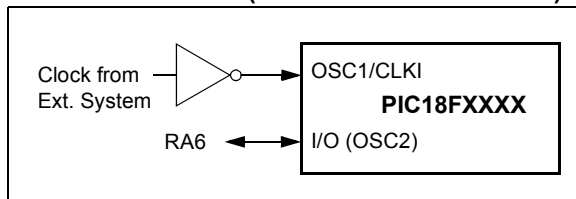

2.5 RC Oscillator

For timing insensitive applications, the "RC" and "RCIO" device options offer additional cost savings. The RC oscillator frequency is a function of the supply voltage, the resistor (R_{EXT}) and capacitor (C_{EXT}) values and the operating temperature. In addition to this, the oscillator frequency will vary from unit to unit due to normal manufacturing variation. Furthermore, the difference in lead frame capacitance between package types will also affect the oscillation frequency, especially for low C_{EXT} values. The user also needs to take into account variation, due to tolerance of external R and C components used. Figure 2-6 shows how the R/C combination is connected.

In the RC Oscillator mode, the oscillator frequency divided by 4 is available on the OSC2 pin. This signal may be used for test purposes, or to synchronize other logic.

FIGURE 2-6: RC OSCILLATOR MODE

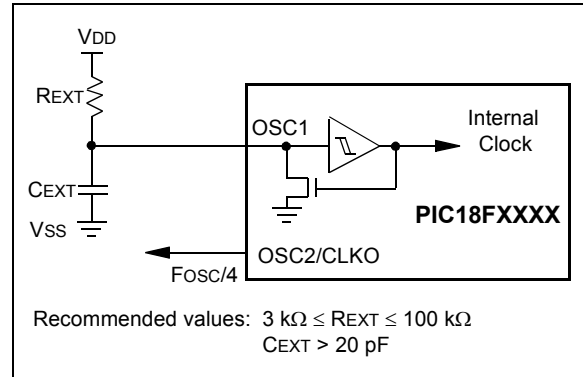

The RCIO Oscillator mode (Figure 2-7) functions like the RC mode, except that the OSC2 pin becomes an additional general purpose I/O pin. The I/O pin becomes bit 6 of PORTA (RA6).

FIGURE 2-7: RCIO OSCILLATOR MODE

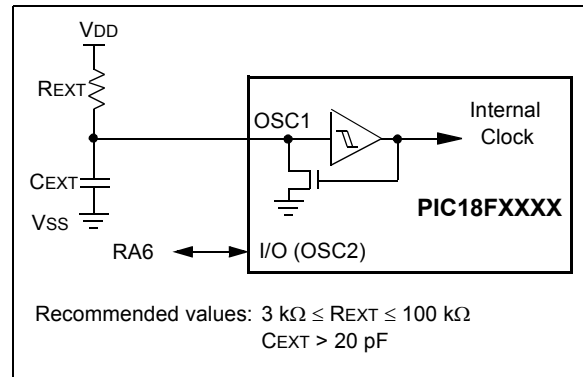

PIC18F1220/1320

2.6 Internal Oscillator Block

The PIC18F1220/1320 devices include an internal oscillator block, which generates two different clock signals; either can be used as the system's clock source. This can eliminate the need for external oscillator circuits on the OSC1 and/or OSC2 pins.

The main output (INTOSC) is an 8 MHz clock source, which can be used to directly drive the system clock. It also drives a postscaler, which can provide a range of clock frequencies from 125 kHz to 4 MHz. The INTOSC output is enabled when a system clock frequency from 125 kHz to 8 MHz is selected.

The other clock source is the internal RC oscillator (INTRC), which provides a 31 kHz output. The INTRC oscillator is enabled by selecting the internal oscillator block as the system clock source, or when any of the following are enabled:

- Power-up Timer
- Fail-Safe Clock Monitor
- Watchdog Timer
- Two-Speed Start-up

These features are discussed in greater detail in Section 19.0 ("Special Features of the CPU").

The clock source frequency (INTOSC direct, INTRC direct or INTOSC postscaler) is selected by configuring the IRCF bits of the OSCCON register (Register 2-2).

2.6.1 INTIO MODES

Using the internal oscillator as the clock source can eliminate the need for up to two external oscillator pins, which can then be used for digital I/O. Two distinct configurations are available:

- In INTIO1 mode, the OSC2 pin outputs Fosc/4, while OSC1 functions as RA7 for digital input and output.
- In INTIO2 mode, OSC1 functions as RA7 and OSC2 functions as RA6, both for digital input and output.

2.6.2 INTRC OUTPUT FREQUENCY

The internal oscillator block is calibrated at the factory to produce an INTOSC output frequency of 8.0 MHz (see Table 22.5). This changes the frequency of the INTRC source from its nominal 31.25 kHz. Peripherals and features that depend on the INTRC source will be affected by this shift in frequency.

Once set during factory calibration, the INTRC frequency will remain within $\pm 2\%$ as temperature and VDD change across their full specified operating ranges.

2.6.3 OSCTUNE REGISTER

The internal oscillator's output has been calibrated at the factory, but can be adjusted in the user's application. This is done by writing to the OSCTUNE register (Register 2-1). The tuning sensitivity is constant throughout the tuning range.

When the OSCTUNE register is modified, the INTOSC and INTRC frequencies will begin shifting to the new frequency. The INTRC clock will reach the new frequency within 8 clock cycles (approximately $8 * 32 \mu\text{s} = 256 \mu\text{s}$). The INTOSC clock will stabilize within 1 ms. Code execution continues during this shift. There is no indication that the shift has occurred. Operation of features that depend on the INTRC clock source frequency, such as the WDT, Fail-Safe Clock Monitor and peripherals, will also be affected by the change in frequency.

REGISTER 2-1: OSCTUNE: OSCILLATOR TUNING REGISTER

	U-0	U-0	R/W-0	R/W-0	R/W-0	R/W-0	R/W-0	R/W-0
	—	—	TUN5	TUN4	TUN3	TUN2	TUN1	TUN0
bit 7								bit 0

bit 7-6 **Unimplemented:** Read as '0'
 bit 5-0 **TUN<5:0>:** Frequency Tuning bits

011111 = Maximum frequency

• •
 • •

000001

000000 = Center frequency. Oscillator module is running at the calibrated frequency.

111111

• •
 • •

100000 = Minimum frequency

Legend:			
R = Readable bit	W = Writable bit	U = Unimplemented bit, read as '0'	
-n = Value at POR	'1' = Bit is set	'0' = Bit is cleared	x = Bit is unknown

2.7 Clock Sources and Oscillator Switching

Like previous PIC18 devices, the PIC18F1220/1320 devices include a feature that allows the system clock source to be switched from the main oscillator to an alternate low frequency clock source. PIC18F1220/1320 devices offer two alternate clock sources. When enabled, these give additional options for switching to the various Power Managed Operating modes.

Essentially, there are three clock sources for these devices:

- Primary oscillators
- Secondary oscillators
- Internal oscillator block

The **primary oscillators** include the external Crystal and Resonator modes, the external RC modes, the external Clock modes and the internal oscillator block. The particular mode is defined on POR by the contents of Configuration Register 1H. The details of these modes are covered earlier in this chapter.

The **secondary oscillators** are those external sources not connected to the OSC1 or OSC2 pins. These sources may continue to operate even after the controller is placed in a Power Managed mode.

PIC18F1220/1320 devices offer only the Timer1 oscillator as a secondary oscillator. This oscillator, in all Power Managed modes, is often the time-base for functions such as a real-time clock.

Most often, a 32.768 kHz watch crystal is connected between the RC0/T1OSO and RC1/T1OSI pins. Like the LP mode oscillator circuit, loading capacitors are also connected from each pin to ground.

The Timer1 oscillator is discussed in greater detail in Section 12.2.

In addition to being a primary clock source, the **internal oscillator block** is available as a Power Managed mode clock source. The INTRC source is also used as the clock source for several special features, such as the WDT and Fail-Safe Clock Monitor.

The clock sources for the PIC18F1220/1320 devices are shown in Figure 2-8. See Section 12.0 for further details of the Timer1 oscillator. See Section 19.1 for Configuration Register details.

PIC18F1220/1320

2.7.1 OSCILLATOR CONTROL REGISTER

The OSCCON register (Register 2-2) controls several aspects of the system clock's operation, both in full power operation and in Power Managed modes.

The System Clock Select bits, SCS1:SCS0, select the clock source that is used when the device is operating in Power Managed modes. The available clock sources are the primary clock (defined in Configuration Register 1H), the secondary clock (Timer1 oscillator), and the internal oscillator block. The clock selection has no effect until a SLEEP instruction is executed and the device enters a Power Managed mode of operation. The SCS bits are cleared on all forms of RESET.

The Internal Oscillator Select bits, IRCF2:IRCF0, select the frequency output of the internal oscillator block that is used to drive the system clock. The choices are the INTRC source, the INTOSC source (8 MHz), or one of the six frequencies derived from the INTOSC postscaler (125 kHz to 4 MHz). If the internal oscillator block is supplying the system clock, changing the states of these bits will have an immediate change on the internal oscillator's output.

The OSTS, IOFS and T1RUN bits indicate which clock source is currently providing the system clock. The OSTS indicates that the Oscillator Start-up Timer has timed out, and the primary clock is providing the system clock in Primary Clock modes. The IOFS bit indicates

when the internal oscillator block has stabilized, and is providing the system clock in RC clock modes. The T1RUN bit (T1CON<6>) indicates when the Timer1 oscillator is providing the system clock in Secondary Clock modes. In Power Managed modes, only one of these three bits will be set at any time. If none of these bits are set, the INTRC is providing the system clock, or the internal oscillator block has just started and is not yet stable.

The IDLEN bit controls the selective shutdown of the controller's CPU in Power Managed modes. The uses of these bits are discussed in more detail in Section 3.0 ("Power Managed Modes").

Note 1: The Timer1 oscillator must be enabled to select the secondary clock source. The Timer1 oscillator is enabled by setting the T1OSCEN bit in the Timer1 Control register (T1CON<3>). If the Timer1 oscillator is not enabled, then any attempt to select a secondary clock source when executing a SLEEP instruction will be ignored.

2: It is recommended that the Timer1 oscillator be operating and stable before executing the SLEEP instruction, or a very long delay may occur while the Timer1 oscillator starts.

FIGURE 2-8: PIC18F1220/1320 CLOCK DIAGRAM

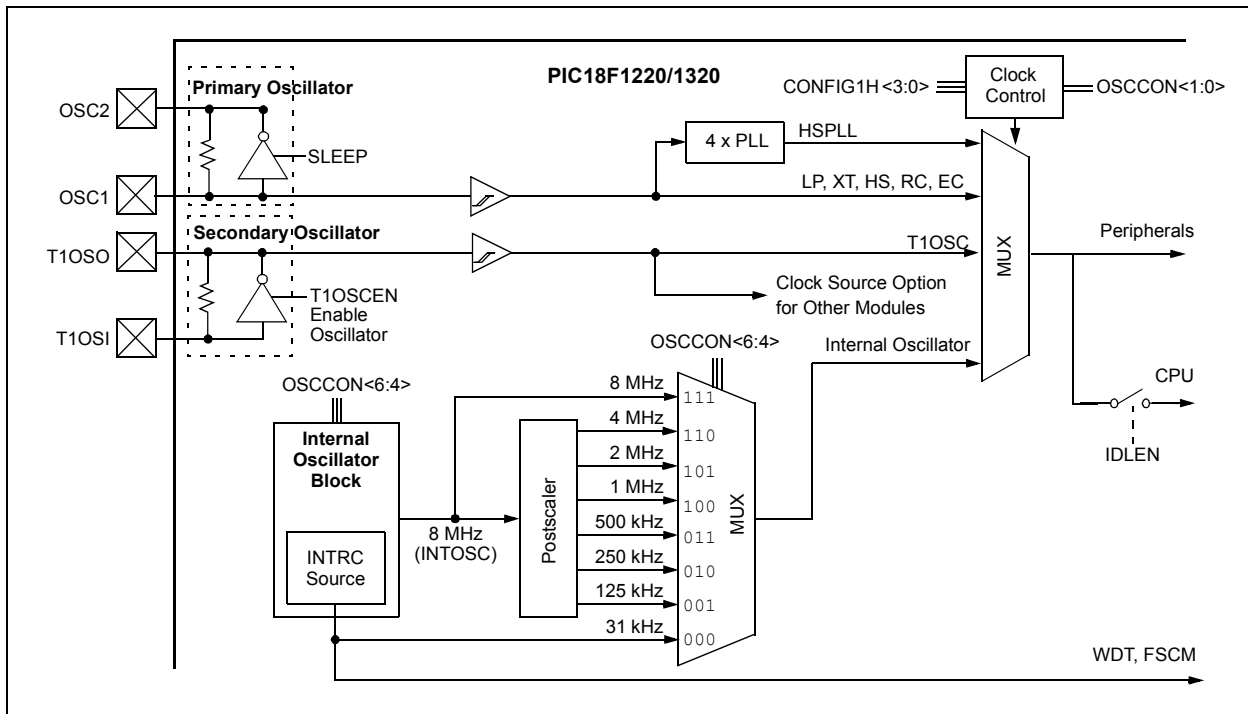

REGISTER 2-2: OSCCON REGISTER

R/W-0	R/W-0	R/W-0	R/W-0	R ⁽¹⁾	R-0	R/W-0	R/W-0
IDLEN	IRCF2	IRCF1	IRCF0	OSTS	IOFS	SCS1	SCS0
bit 7							bit 0

- bit 7 **IDLEN:** IDLE Enable bits
 1 = IDLE mode enabled; CPU core is not clocked in Power Managed modes
 0 = RUN mode enabled; CPU core is clocked in Power Managed modes
- bit 6-4 **IRCF2:IRCF0:** Internal Oscillator Frequency Select bits
 111 = 8 MHz (8 MHz source drives clock directly)
 110 = 4 MHz
 101 = 2 MHz
 100 = 1 MHz
 011 = 500 kHz
 010 = 250 kHz
 001 = 125 kHz
 000 = 31 kHz (INTRC source drives clock directly)
- bit 3 **OSTS:** Oscillator Start-up Time-out Status bit
 1 = Oscillator start-up time-out timer has expired; primary oscillator is running
 0 = Oscillator start-up time-out timer is running; primary oscillator is not ready
- bit 2 **IOFS:** INTOSC Frequency Stable bit
 1 = INTOSC frequency is stable
 0 = INTOSC frequency is not stable
- bit 1-0 **SCS1:SCS0:** System Clock Select bits
 1x = Internal oscillator block (RC modes)
 01 = Timer1 oscillator (Secondary modes)
 00 = Primary oscillator (SLEEP and PRI_IDLE modes)

Note 1: Depends on state of the IESO bit in Configuration Register 1H.

Legend:			
R = Readable bit	W = Writable bit	U = Unimplemented bit, read as '0'	
- n = Value at POR	'1' = Bit is set	'0' = Bit is cleared	x = Bit is unknown

PIC18F1220/1320

2.7.2 OSCILLATOR TRANSITIONS

The PIC18F1220/1320 devices contain circuitry to prevent clocking “glitches” when switching between clock sources. A short pause in the system clock occurs during the clock switch. The length of this pause is between 8 and 9 clock periods of the new clock source. This ensures that the new clock source is stable and that its pulse width will not be less than the shortest pulse width of the two clock sources.

Clock transitions are discussed in greater detail in Section 3.1.2, “Entering Power Managed Modes”.

2.8 Effects of Power Managed Modes on the Various Clock Sources

When the device executes a `SLEEP` instruction, the system is switched to one of the Power Managed modes, depending on the state of the `IDLEN` and `SCS1:SCS0` bits of the `OSCCON` register. See Section 3.0 (“Power Managed Modes”) for details.

When `PRI_IDLE` mode is selected, the designated primary oscillator continues to run without interruption. For all other Power Managed modes, the oscillator using the `OSC1` pin is disabled. The `OSC1` pin (and `OSC2` pin, if used by the oscillator) will stop oscillating.

In Secondary Clock modes (`SEC_RUN` and `SEC_IDLE`), the `Timer1` oscillator is operating and providing the system clock. The `Timer1` oscillator may also run in all Power Managed modes if required to clock `Timer1` or `Timer3`.

In Internal Oscillator modes (`RC_RUN` and `RC_IDLE`), the internal oscillator block provides the system clock source. The `INTRC` output can be used directly to provide the system clock and may be enabled to support various special features, regardless of the Power Managed mode (see Sections 19.2 through 19.4). The `INTOSC` output at 8 MHz may be used directly to clock the system, or may be divided down first. The `INTOSC` output is disabled if the system clock is provided directly from the `INTRC` output.

If the `SLEEP` mode is selected, all clock sources are stopped. Since all the transistor switching currents have been stopped, `SLEEP` mode achieves the lowest current consumption of the device (only leakage currents).

Enabling any on-chip feature that will operate during `SLEEP` will increase the current consumed during `SLEEP`. The `INTRC` is required to support `WDT` operation. The `Timer1` oscillator may be operating to support a real-time clock. Other features may be operating that do not require a system clock source (i.e., `SSP` slave, `PSP`, `INTn` pins, `A/D` conversions, and others).

2.9 Power-up Delays

Power-up delays are controlled by two timers, so that no external `RESET` circuitry is required for most applications. The delays ensure that the device is kept in `RESET` until the device power supply is stable under normal circumstances, and the primary clock is operating and stable. For additional information on power-up delays, see Sections 4.1 through 4.5.

The first timer is the Power-up Timer (`PWRT`), which provides a fixed delay on power-up (parameter 33, Table 22-7), if enabled in Configuration Register 2L. The second timer is the Oscillator Start-up Timer (`OST`), intended to keep the chip in `RESET` until the crystal oscillator is stable (`LP`, `XT` and `HS` modes). The `OST` does this by counting 1024 oscillator cycles before allowing the oscillator to clock the device.

When the `HSPLL` Oscillator mode is selected, the device is kept in `RESET` for an additional 2 ms following the `HS` mode `OST` delay, so the `PLL` can lock to the incoming clock frequency.

There is a delay of 5 to 10 μ s following `POR` while the controller becomes ready to execute instructions. This delay runs concurrently with any other delays. This may be the only delay that occurs when any of the `EC`, `RC`, or `INTIO` modes are used as the primary clock source.

TABLE 2-3: OSC1 AND OSC2 PIN STATES IN SLEEP MODE

OSC Mode	OSC1 Pin	OSC2 Pin
RC, INTIO1	Floating, external resistor should pull high	At logic low (clock/4 output)
RCIO, INTIO2	Floating, external resistor should pull high	Configured as PORTA, bit 6
ECIO	Floating, pulled by external clock	Configured as PORTA, bit 6
EC	Floating, pulled by external clock	At logic low (clock/4 output)
LP, XT, and HS	Feedback inverter disabled at quiescent voltage level	Feedback inverter disabled at quiescent voltage level

Note: See Table 4-1 in Section 4.0, for time-outs due to `SLEEP` and `MCLR` Reset.

3.0 POWER MANAGED MODES

The PIC18F1220/1320 devices offer a total of six Operating modes for more efficient power management. These provide a variety of options for selective power conservation in applications where resources may be limited (i.e., battery powered devices).

There are three categories of Power Managed modes:

- SLEEP mode
- IDLE modes
- RUN modes

These categories define which portions of the device are clocked and sometimes, what speed. The RUN and IDLE modes may use any of the three available clock sources (Primary, Secondary or INTOSC multiplexer); the SLEEP mode does not use a clock source.

The clock switching feature offered in other PIC18 devices (i.e., using the Timer1 oscillator in place of the primary oscillator), and the SLEEP mode offered by all PICmicro® devices (where all system clocks are stopped) are both offered in the PIC18F1220/1320 devices (SEC_RUN and SLEEP modes, respectively). However, additional Power Managed modes are available that allow the user greater flexibility in determining what portions of the device are operating. The Power Managed modes are event driven; that is, some specific event must occur for the device to enter or (more particularly) exit these Operating modes.

For PIC18F1220/1320 devices, the Power Managed modes are invoked by using the existing SLEEP instruction. All modes exit to PRI_RUN mode when triggered by an interrupt, a RESET, or a WDT time-out (PRI_RUN mode is the normal Full Power Execution mode; the CPU and peripherals are clocked by the primary oscillator source). In addition, Power Managed RUN modes may also exit to SLEEP mode, or their corresponding IDLE mode.

3.1 Selecting Power Managed Modes

Selecting a Power Managed mode requires deciding if the CPU is to be clocked or not, and selecting a clock source. The IDLEN bit controls CPU clocking, while the SC1:SCS0 bits select a clock source. The individual modes, bit settings, clock sources, and affected modules are summarized in Table 3-1.

3.1.1 CLOCK SOURCES

The clock source is selected by setting the SCS bits of the OSCCON register (Register 2-2). Three clock sources are available for use in Power Managed IDLE modes: the primary clock (as configured in Configuration Register 1H), the secondary clock (Timer1 oscillator), and the internal oscillator block. The secondary and internal oscillator block sources are available for the Power Managed modes (PRI_RUN mode is the normal Full Power Execution mode; the CPU and peripherals are clocked by the primary oscillator source).

TABLE 3-1: POWER MANAGED MODES

Mode	OSCCON Bits		Module Clocking		Available Clock and Oscillator Source
	IDLEN <7>	SCS1:SCS0 <1:0>	CPU	Peripherals	
SLEEP	0	00	Off	Off	None - All clocks are disabled
PRI_RUN	0	00	Clocked	Clocked	Primary - LP, XT, HS, HSPLL, RC, EC, INTRC ⁽¹⁾ This is the normal Full Power Execution mode.
SEC_RUN	0	01	Clocked	Clocked	Secondary - Timer1 Oscillator
RC_RUN	0	1X	Clocked	Clocked	Internal Oscillator Block ⁽¹⁾
PRI_IDLE	1	00	Off	Clocked	Primary - LP, XT, HS, HSPLL, RC, EC
SEC_IDLE	1	01	Off	Clocked	Secondary - Timer1 Oscillator
RC_IDLE	1	1X	Off	Clocked	Internal Oscillator Block ⁽¹⁾

Note 1: Includes INTOSC and INTOSC postscaler, as well as the INTRC source.

PIC18F1220/1320

3.1.2 ENTERING POWER MANAGED MODES

In general, entry, exit, and switching between Power Managed clock sources requires clock source switching. In each case, the sequence of events is the same.

Any change in the Power Managed mode begins with loading the OSCCON register and executing a `SLEEP` instruction. The `SCS1:SCS0` bits select one of three power managed clock sources; the primary clock (as defined in Configuration Register 1H), the secondary clock (the Timer1 oscillator), and the internal oscillator block (used in RC modes). Modifying the `SCS` bits will have no effect until a `SLEEP` instruction is executed. Entry to the Power Managed mode is triggered by the execution of a `SLEEP` instruction.

Figure 3-5 shows how the system is clocked while switching from the primary clock to the Timer1 oscillator. When the `SLEEP` instruction is executed, clocks to the device are stopped at the beginning of the next instruction cycle. Eight clock cycles from the new clock source are counted to synchronize with the new clock source. After 8 clock pulses from the new clock source are counted, clocks from the new clock source resume clocking the system. The actual length of the pause is between 8 and 9 clock periods from the new clock source. This ensures that the new clock source is stable and that its pulse width will not be less than the shortest pulse width of the two clock sources.

Three bits indicate the current clock source: `OSTS` and `IOFS` in the `OSCCON` register, and `T1RUN` in the `T1CON` register. Only one of these bits will be set while in a Power Managed mode. When the `OSTS` bit is set, the primary clock is providing the system clock. When the `IOFS` bit is set, the `INTOSC` output is providing a stable 8 MHz clock source and is providing the system clock. When the `T1RUN` bit is set, the Timer1 oscillator is providing the system clock. If none of these bits are set, then either the `INTRC` clock source is clocking the system, or the `INTOSC` source is not yet stable.

If the internal oscillator block is configured as the primary clock source in Configuration Register 1H, then both the `OSTS` and `IOFS` bits may be set when in `PRI_RUN` or `PRI_IDLE` modes. This indicates that the primary clock (`INTOSC` output) is generating a stable 8 MHz output. Entering an RC Power Managed mode (same frequency) would clear the `OSTS` bit.

Note 1: Caution should be used when modifying a single `IRCF` bit. If `VDD` is less than 3V, it is possible to select a higher clock speed than is supported by the low `VDD`. Improper device operation may result if the `VDD/FOSC` specifications are violated.

2: Executing a `SLEEP` instruction does not necessarily place the device into `SLEEP` mode; executing a `SLEEP` instruction is simply a trigger to place the controller into a Power Managed mode selected by the `OSCCON` register, one of which is `SLEEP` mode.

3.1.3 MULTIPLE SLEEP COMMANDS

The Power Managed mode that is invoked with the `SLEEP` instruction is determined by the settings of the `IDLEN` and `SCS` bits at the time the instruction is executed. If another `SLEEP` instruction is executed, the device will enter the Power Managed mode specified by these same bits at that time. If the bits have changed, the device will enter the new Power Managed mode specified by the new bit settings.

3.1.4 COMPARISONS BETWEEN RUN AND IDLE MODES

Clock source selection for the `RUN` modes is identical to the corresponding `IDLE` modes. When a `SLEEP` instruction is executed, the `SCS` bits in the `OSCCON` register are used to switch to a different clock source. As a result, if there is a change of clock source at the time a `SLEEP` instruction is executed, a clock switch will occur.

In `IDLE` modes, the CPU is not clocked and is not running. In `RUN` modes, the CPU is clocked and executing code. This difference modifies the operation of the `WDT` when it times out. In `IDLE` modes, a `WDT` time-out results in a wake from Power Managed modes. In `RUN` modes, a `WDT` time-out results in a `WDT Reset` (see Table 3-2).

During a wake-up from an `IDLE` mode, the CPU starts executing code by entering the corresponding `RUN` mode, until the primary clock becomes ready. When the primary clock becomes ready, the clock source is automatically switched to the primary clock. The `IDLEN` and `SCS` bits are unchanged during and after the wake-up.

Figure 3-2 shows how the system is clocked during the clock source switch. The example assumes the device was in `SEC_IDLE` or `SEC_RUN` mode when a wake is triggered (the primary clock was configured in `HSPLL` mode).

TABLE 3-2: COMPARISON BETWEEN POWER MANAGED MODES

Power Managed Mode	CPU is clocked by ...	WDT time-out causes a ...	Peripherals are clocked by ...	Clock during Wake-up (while primary becomes ready)
SLEEP	Not clocked (not running)	Wake-up	Not clocked	None, or INTOSC multiplexer if Two-Speed Start-up or Fail-Safe Clock Monitor are enabled
Any IDLE mode	Not clocked (not running)	Wake-up	Primary, Secondary, or INTOSC multiplexer	Unchanged from IDLE mode (CPU operates as in corresponding RUN mode)
Any RUN mode	Secondary, or INTOSC multiplexer	RESET	Secondary, or INTOSC multiplexer	Unchanged from RUN mode

3.2 SLEEP Mode

The Power Managed SLEEP mode in the PIC18F1220/1320 devices is identical to that offered in all other PICmicro microcontrollers. It is entered by clearing the IDLEN and SCS1:SCS0 bits (this is the RESET state), and executing the SLEEP instruction. This shuts down the primary oscillator, and the OSTS bit is cleared (see Figure 3-1).

When a wake event occurs in SLEEP mode (by interrupt, RESET, or WDT time-out), the system will not be clocked until the primary clock source becomes ready (see Figure 3-2), or it will be clocked from the internal oscillator block if either the Two-Speed Start-up or the Fail-Safe Clock Monitor are enabled (see Section 19.0, "Special Features of the CPU"). In either case, the OSTS bit is set when the primary clock is providing the system clocks. The IDLEN and SCS bits are not affected by the wake-up.

3.3 IDLE Modes

The IDLEN bit allows the microcontroller's CPU to be selectively shutdown while the peripherals continue to operate. Clearing IDLEN allows the CPU to be clocked. Setting IDLEN disables clocks to the CPU, effectively stopping program execution (see Register 2-2). The peripherals continue to be clocked regardless of the setting of the IDLEN bit.

There is one exception to how the IDLEN bit functions. When all the low power OSCCON bits are cleared (IDLEN:SCS1:SCS0 = 000), the device enters SLEEP mode upon the execution of the SLEEP instruction. This is both the RESET state of the OSCCON register, and the setting that selects SLEEP mode. This maintains compatibility with other PICmicro devices that do not offer Power Managed modes.

If the IDLE Enable bit, IDLEN (OSCCON<7>), is set to a '1' when a SLEEP instruction is executed, the peripherals will be clocked from the clock source selected using the SCS1:SCS0 bits; however, the CPU will not be clocked. Since the CPU is not executing instructions, the only exits from any of the IDLE modes are by interrupt, WDT time-out or a RESET.

When a wake event occurs, CPU execution is delayed approximately 10 μs while it becomes ready to execute code. When the CPU begins executing code, it is clocked by the same clock source as was selected in the Power Managed mode (i.e., when waking from RC_IDLE mode, the internal oscillator block will clock the CPU and peripherals until the primary clock source becomes ready – this is essentially RC_RUN mode). This continues until the primary clock source becomes ready. When the primary clock becomes ready, the OSTS bit is set, and the system clock source is switched to the primary clock (see Figure 3-4). The IDLEN and SCS bits are not affected by the wake-up.

While in any IDLE mode or the SLEEP mode, a WDT time-out will result in a WDT wake-up to full power operation.

PIC18F1220/1320

FIGURE 3-1: TIMING TRANSITION FOR ENTRY TO SLEEP MODE

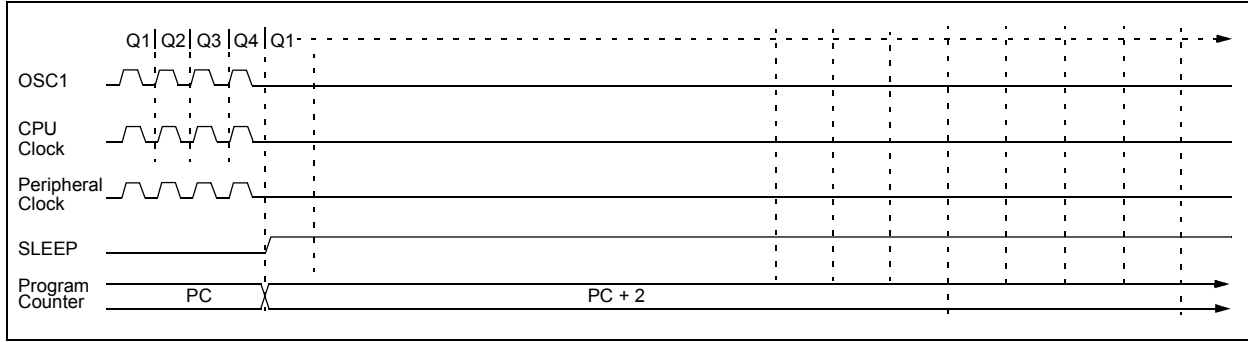
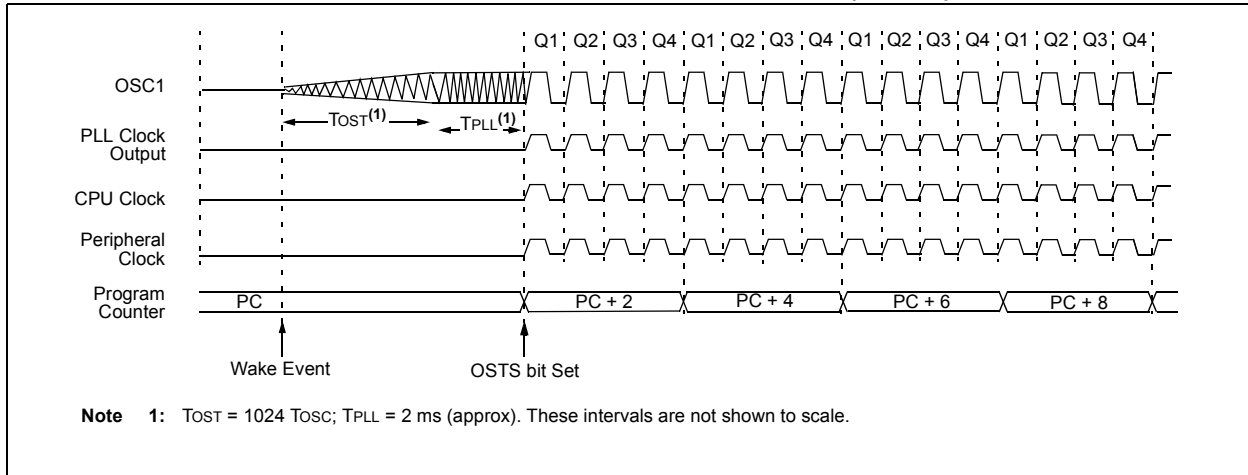

FIGURE 3-2: TRANSITION TIMING FOR WAKE FROM SLEEP (HSPLL)



3.3.1 PRI_IDLE MODE

This mode is unique among the three Low Power IDLE modes, in that it does not disable the primary system clock. For timing sensitive applications, this allows for the fastest resumption of device operation with its more accurate primary clock source, since the clock source does not have to “warm up” or transition from another oscillator.

PRI_IDLE mode is entered by setting the IDLEN bit, clearing the SCS bits, and executing a `SLEEP` instruction. Although the CPU is disabled, the peripherals continue to be clocked from the primary clock source specified in Configuration Register 1H. The OSTS bit remains set in PRI_IDLE mode (see Figure 3-3).

When a wake event occurs, the CPU is clocked from the primary clock source. A delay of approximately 10 μs is required between the wake event and code execution starts. This is required to allow the CPU to become ready to execute instructions. After the wake-up, the OSTS bit remains set. The IDLEN and SCS bits are not affected by the wake-up (see Figure 3-4).

FIGURE 3-3: TRANSITION TIMING TO PRI_IDLE MODE

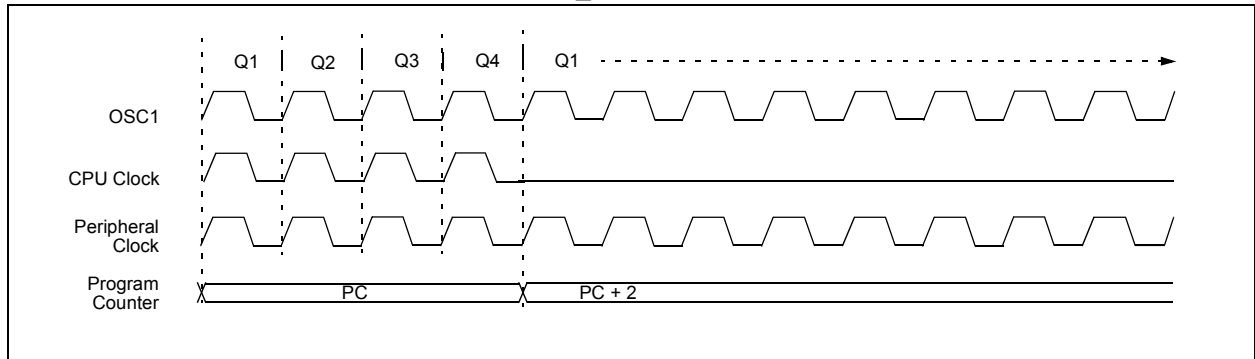
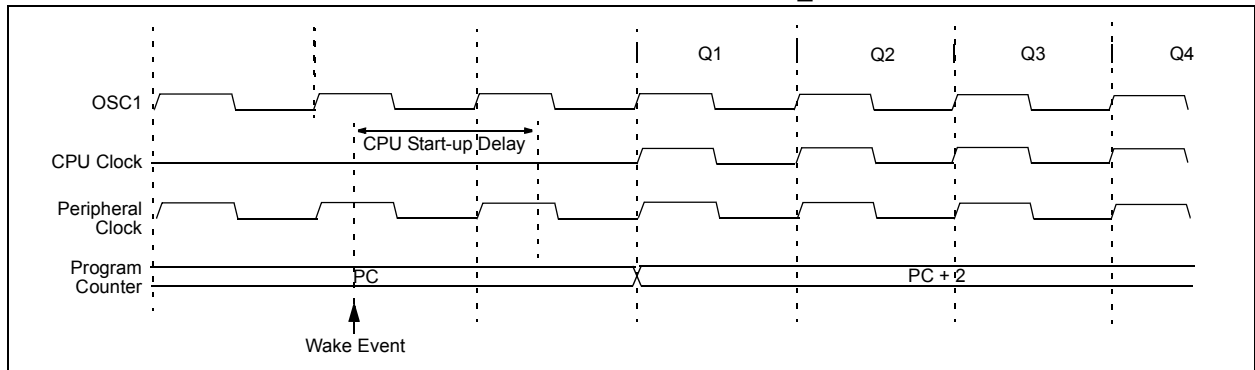

FIGURE 3-4: TRANSITION TIMING FOR WAKE FROM PRI_IDLE MODE



PIC18F1220/1320

3.3.2 SEC_IDLE MODE

In SEC_IDLE mode, the CPU is disabled, but the peripherals continue to be clocked from the Timer1 oscillator. This mode is entered by setting the IDLE bit, modifying to SCS1:SCS0 = 01, and executing a SLEEP instruction. When the clock source is switched (see Figure 3-5) to the Timer1 oscillator, the primary oscillator is shutdown, the OSTS bit is cleared, and the T1RUN bit is set.

Note: The Timer1 oscillator should already be running prior to entering SEC_IDLE mode. If the T1OSCEN bit is not set when the SLEEP instruction is executed, the SLEEP instruction will be ignored and entry to SEC_IDLE mode will not occur. If the Timer1 oscillator is enabled, but not yet running, peripheral clocks will be delayed until the oscillator has started; in such situations, initial oscillator operation is far from stable and unpredictable operation may result.

When a wake event occurs, the peripherals continue to be clocked from the Timer1 oscillator. After a 10 μs delay following the wake event, the CPU begins executing code, being clocked by the Timer1 oscillator. The microcontroller operates in SEC_RUN mode until the primary clock becomes ready. When the primary clock becomes ready, a clock switchback to the primary clock occurs (see Figure 3-6). When the clock switch is complete, the T1RUN bit is cleared, the OSTS bit is set, and the primary clock is providing the system clock. The IDLEN and SCS bits are not affected by the wake-up. The Timer1 oscillator continues to run.

FIGURE 3-5: TIMING TRANSITION FOR ENTRY TO SEC_IDLE MODE

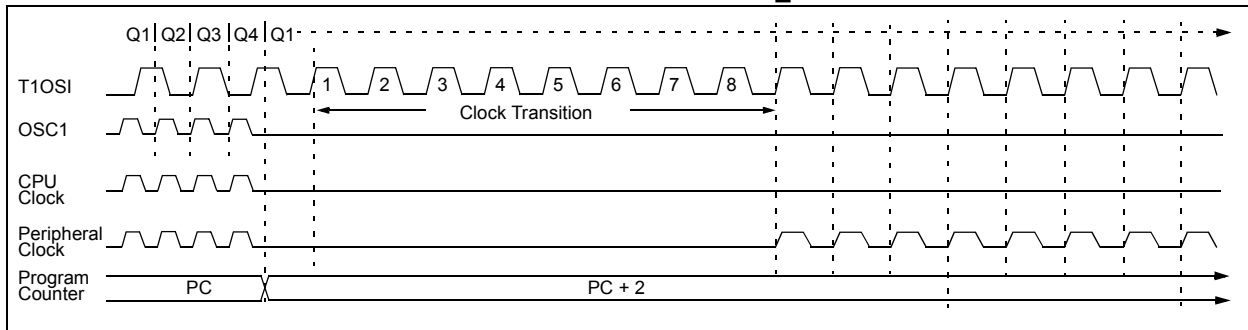
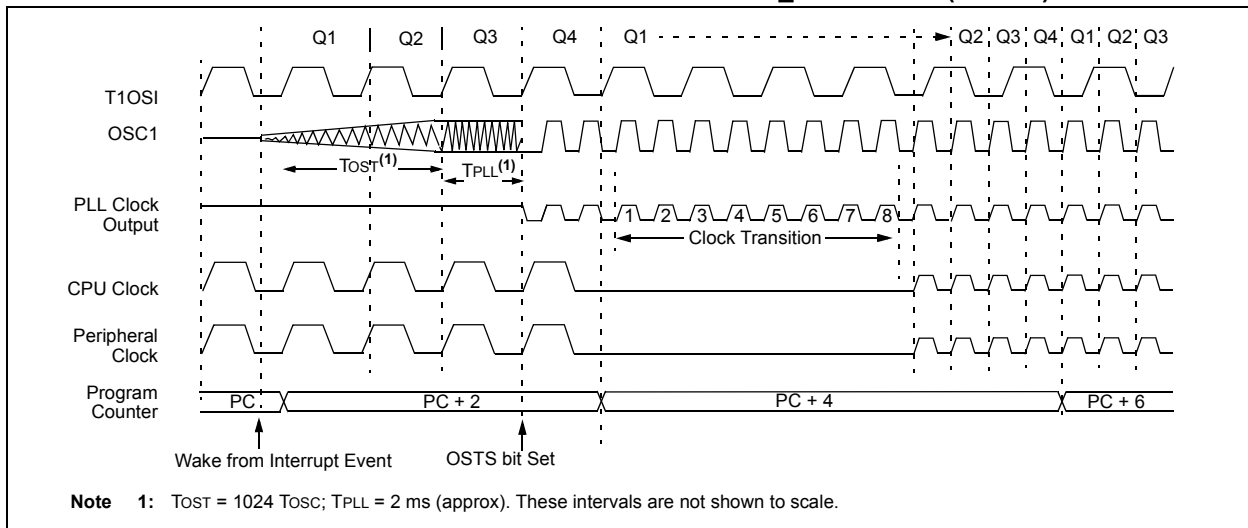

FIGURE 3-6: TIMING TRANSITION FOR WAKE FROM SEC_RUN MODE (HSPLL)



3.3.3 RC_IDLE MODE

In RC_IDLE mode, the CPU is disabled, but the peripherals continue to be clocked from the internal oscillator block using the INTOSC multiplexer. This mode allows for controllable power conservation during IDLE periods.

This mode is entered by setting the IDLEN bit, setting SCS1 (SCS0 is ignored), and executing a SLEEP instruction. The INTOSC multiplexer may be used to select a higher clock frequency by modifying the IRCF bits before executing the SLEEP instruction. When the clock source is switched to the INTOSC multiplexer (see Figure 3-7), the primary oscillator is shutdown, and the OSTS bit is cleared.

If the IRCF bits are set to a non-zero value (thus, enabling the INTOSC output), the IOFS bit becomes set after the INTOSC output becomes stable, in about 1 ms. Clocks to the peripherals continue while the INTOSC source stabilizes. If the IRCF bits were previ-

ously at a non-zero value before the SLEEP instruction was executed, and the INTOSC source was already stable, the IOFS bit will remain set. If the IRCF bits are all clear, the INTOSC output is not enabled, and the IOFS bit will remain clear; there will be no indication of the current clock source.

When a wake event occurs, the peripherals continue to be clocked from the INTOSC multiplexer. After a 10 μs delay following the wake event, the CPU begins executing code, being clocked by the INTOSC multiplexer. The microcontroller operates in RC_RUN mode until the primary clock becomes ready. When the primary clock becomes ready, a clock switchback to the primary clock occurs (see Figure 3-8). When the clock switch is complete, the IOFS bit is cleared, the OSTS bit is set, and the primary clock is providing the system clock. The IDLEN and SCS bits are not affected by the wakeup. The INTRC source will continue to run if either the WDT or the Fail-Safe Clock Monitor is enabled.

FIGURE 3-7: TIMING TRANSITION TO RC_IDLE MODE

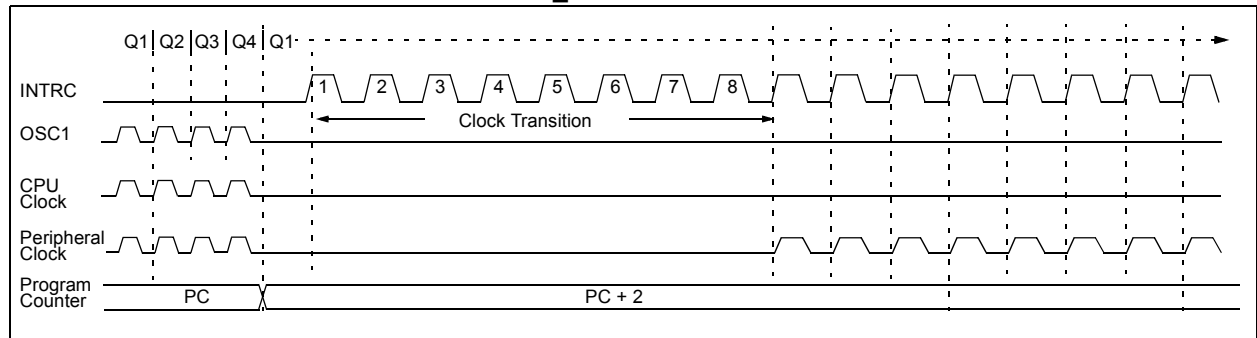
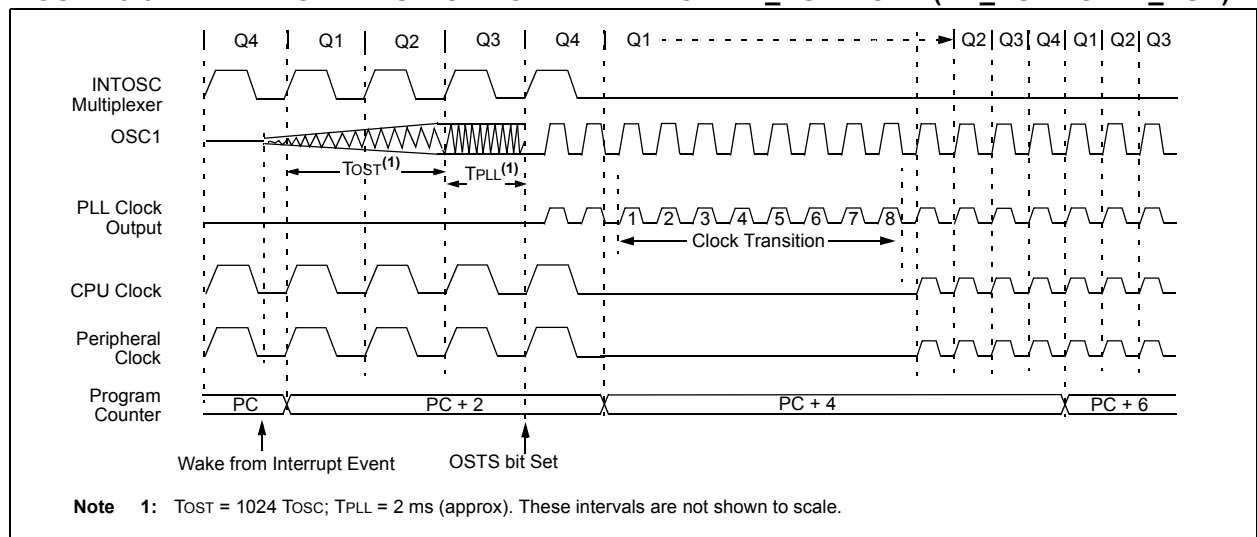

FIGURE 3-8: TIMING TRANSITION FOR WAKE FROM RC_RUN MODE (RC_RUN TO PRI_RUN)



PIC18F1220/1320

3.4 RUN Modes

If the IDLEN bit is clear when a SLEEP instruction is executed, the CPU and peripherals are both clocked from the source selected using the SCS1:SCS0 bits. While these operating modes may not afford the power conservation of IDLE or SLEEP modes, they do allow the device to continue executing instructions by using a lower frequency clock source. RC_RUN mode also offers the possibility of executing code at a frequency greater than the primary clock.

Wake-up from a Power Managed RUN mode can be triggered by an interrupt, or any RESET, to return to full power operation. As the CPU is executing code in RUN modes, several additional exits from RUN modes are possible. They include exit to SLEEP mode, exit to a corresponding IDLE mode, and exit by executing a RESET instruction. While the device is in any of the Power Managed RUN modes, a WDT time-out will result in a WDT Reset.

3.4.1 PRI_RUN MODE

The PRI_RUN mode is the normal Full Power Execution mode. If the SLEEP instruction is never executed, the microcontroller operates in this mode (a SLEEP instruction is executed to enter all other Power Managed modes). All other Power Managed modes exit to PRI_RUN mode when an interrupt or WDT time-out occur.

There is no entry to PRI_RUN mode. The OSTS bit is set. The IOFS bit may be set if the internal oscillator block is the primary clock source (see Section 2.7.1, "Oscillator Control Register").

3.4.2 SEC_RUN MODE

The SEC_RUN mode is the compatible mode to the "clock switching" feature offered in other PIC18 devices. In this mode, the CPU and peripherals are clocked from the Timer1 oscillator. This gives users the option of lower power consumption while still using a high accuracy clock source.

SEC_RUN mode is entered by clearing the IDLEN bit, setting SCS1:SCS0 = 01, and executing a SLEEP instruction. The system clock source is switched to the Timer1 oscillator (see Figure 3-9), the primary oscillator is shutdown, the T1RUN bit (T1CON<6>) is set, and the OSTS bit is cleared.

Note: The Timer1 oscillator should already be running prior to entering SEC_RUN mode. If the T1OSCEN bit is not set when the SLEEP instruction is executed, the SLEEP instruction will be ignored and entry to SEC_RUN mode will not occur. If the Timer1 oscillator is enabled, but not yet running, system clocks will be delayed until the oscillator has started; in such situations, initial oscillator operation is far from stable and unpredictable operation may result.

When a wake event occurs, the peripherals and CPU continue to be clocked from the Timer1 oscillator while the primary clock is started. When the primary clock becomes ready, a clock switchback to the primary clock occurs (see Figure 3-6). When the clock switch is complete, the T1RUN bit is cleared, the OSTS bit is set, and the primary clock is providing the system clock. The IDLEN and SCS bits are not affected by the wake-up. The Timer1 oscillator continues to run.

Firmware can force an exit from SEC_RUN mode. By clearing the T1OSCEN bit (T1CON<3>), an exit from SEC_RUN back to normal full power operation is triggered. The Timer1 oscillator will continue to run and provide the system clock, even though the T1OSCEN bit is cleared. The primary clock is started. When the primary clock becomes ready, a clock switchback to the primary clock occurs (see Figure 3-6). When the clock switch is complete, the Timer1 oscillator is disabled, the T1RUN bit is cleared, the OSTS bit is set, and the primary clock is providing the system clock. The IDLEN and SCS bits are not affected by the wake-up.

FIGURE 3-9: TIMING TRANSITION FOR ENTRY TO SEC_RUN MODE

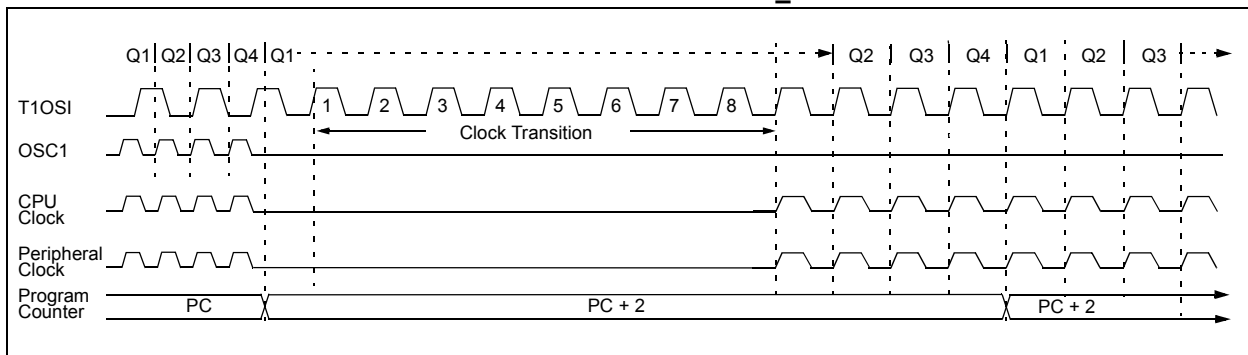

3.4.3 RC_RUN MODE

In RC_RUN mode, the CPU and peripherals are clocked from the internal oscillator block using the INTOSC multiplexer, and the primary clock is shut-down. When using the INTRC source, this mode provides the best power conservation of all the RUN modes, while still executing code. It works well for user applications which are not highly timing sensitive, or do not require high speed clocks at all times.

If the primary clock source is the internal oscillator block (either of the INTIO1 or INTIO2 oscillators), there are no distinguishable differences between PRI_RUN and RC_RUN modes during execution. However, a clock switch delay will occur during entry to, and exit from RC_RUN mode. Therefore, if the primary clock source is the internal oscillator block, the use of RC_RUN mode is not recommended.

This mode is entered by clearing the IDLEN bit, setting SCS1 (SCS0 is ignored), and executing a SLEEP instruction. The IRCF bits may select the clock frequency before the SLEEP instruction is executed. When the clock source is switched to the INTOSC multiplexer (see Figure 3-10), the primary oscillator is shutdown, and the OSTS bit is cleared.

The IRCF bits may be modified at any time to immediately change the system clock speed. Executing a SLEEP instruction is not required to select a new clock frequency from the INTOSC multiplexer.

Note: Caution should be used when modifying a single IRCF bit. If VDD is less than 3V, it is possible to select a higher clock speed than is supported by the low VDD. Improper device operation may result if the VDD/FOSC specifications are violated.

If the IRCF bits are all clear, the INTOSC output is not enabled and the IOFS bit will remain clear; there will be no indication of the current clock source. The INTRC source is providing the system clocks.

If the IRCF bits are changed from all clear (thus, enabling the INTOSC output), the IOFS bit becomes set after the INTOSC output becomes stable. Clocks to the system continue while the INTOSC source stabilizes, in approximately 1 ms.

If the IRCF bits were previously at a non-zero value before the SLEEP instruction was executed, and the INTOSC source was already stable, the IOFS bit will remain set.

When a wake event occurs, the system continues to be clocked from the INTOSC multiplexer while the primary clock is started. When the primary clock becomes ready, a clock switch to the primary clock occurs (see Figure 3-8). When the clock switch is complete, the IOFS bit is cleared, the OSTS bit is set, and the primary clock is providing the system clock. The IDLEN and SCS bits are not affected by the wake-up. The INTRC source will continue to run if either the WDT or the Fail-Safe Clock Monitor is enabled.

FIGURE 3-10: TIMING TRANSITION TO RC_RUN MODE

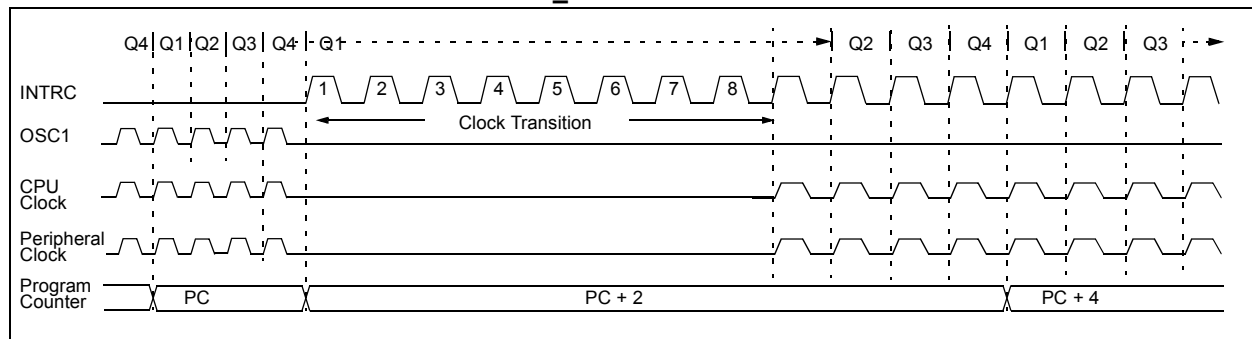

PIC18F1220/1320

3.4.4 EXIT TO IDLE MODE

An exit from a Power Managed RUN mode to its corresponding IDLE mode is executed by setting the IDLEN bit and executing a `SLEEP` instruction. The CPU is halted at the beginning of the instruction following the `SLEEP` instruction. There are no changes to any of the clock source status bits (OSTS, IOFS, or T1RUN). While the CPU is halted, the peripherals continue to be clocked from the previously selected clock source.

3.4.5 EXIT TO SLEEP MODE

An exit from a Power Managed RUN mode to SLEEP mode is executed by clearing the IDLEN and SCS1:SCS0 bits and executing a `SLEEP` instruction. The code is no different than the method used to invoke SLEEP mode from the normal Operating (Full Power) mode.

The primary clock and internal oscillator block are disabled. The INTRC will continue to operate if the WDT is enabled. The Timer1 oscillator will continue to run, if enabled in the T1CON register (Register 12-1). All clock source status bits are cleared (OSTS, IOFS, and T1RUN).

3.5 Wake from Power Managed Modes

An exit from any of the Power Managed modes is triggered by an interrupt, a RESET, or a WDT time-out. This section discusses the triggers that cause exits from Power Managed modes. The clocking subsystem actions are discussed in each of the Power Managed modes (see Sections 3.2 through 3.4).

<p>Note: If application code is timing sensitive, it should wait for the OSTS bit to become set before continuing. Use the interval during the low power exit sequence (before OSTS is set) to perform timing insensitive "housekeeping" tasks.</p>
--

Device behavior during Low Power mode exits is summarized in Table 3-3.

3.5.1 EXIT BY INTERRUPT

Any of the available interrupt sources can cause the device to exit a Power Managed mode and resume full power operation. To enable this functionality, an interrupt source must be enabled by setting its enable bit in one of the INTCON or PIE registers. The exit sequence is initiated when the corresponding interrupt flag bit is set. On all exits from Lower Power mode by interrupt, code execution branches to the interrupt vector if the GIE/GIEH bit (INTCON<7>) is set. Otherwise, code execution continues or resumes without branching (see Section 9.0, "Interrupts").

TABLE 3-3: ACTIVITY AND EXIT DELAY ON WAKE FROM SLEEP MODE OR ANY IDLE MODE (BY CLOCK SOURCES)

Clock in Power Managed Mode	Primary System Clock	Power Managed Mode Exit Delay	Clock Ready Status Bit (OSCCON)	Activity during Wake from Power Managed Mode	
				Exit by Interrupt	Exit by RESET
Primary System Clock (PRI_IDLE mode)	LP, XT, HS	5-10 μ s ⁽⁵⁾	OSTS	CPU and peripherals clocked by primary clock and executing instructions.	Not clocked, or Two-Speed Start-up (if enabled) ⁽³⁾ .
	HSPLL		—		
	EC, RC, INTRC ⁽¹⁾		—		
	INTOSC ⁽²⁾		IOFS		
T1OSC or INTRC ⁽¹⁾	LP, XT, HS	OST	OSTS	CPU and peripherals clocked by selected Power Managed mode clock, and executing instructions until primary clock source becomes ready.	
	HSPLL	OST + 2 ms			
	EC, RC, INTRC ⁽¹⁾	5-10 μ s ⁽⁵⁾	—		
	INTOSC ⁽²⁾	1 ms ⁽⁴⁾	IOFS		
INTOSC ⁽²⁾	LP, XT, HS	OST	OSTS		
	HSPLL	OST + 2 ms			
	EC, RC, INTRC ⁽¹⁾	5-10 μ s ⁽⁵⁾	—		
	INTOSC ⁽²⁾	None	IOFS		
SLEEP mode	LP, XT, HS	OST	OSTS	Not clocked, or Two-Speed Start-up (if enabled) until primary clock source becomes ready ⁽³⁾ .	
	HSPLL	OST + 2 ms			
	EC, RC, INTRC ⁽¹⁾	5-10 μ s ⁽⁵⁾	—		
	INTOSC ⁽²⁾	1 ms ⁽⁴⁾	IOFS		

- Note 1:** In this instance, refers specifically to the INTRC clock source.
Note 2: Includes both the INTOSC 8 MHz source and postscaler derived frequencies.
Note 3: Two-Speed Start-up is covered in greater detail in Section 19.3.
Note 4: Execution continues during the INTOSC stabilization period.
Note 5: Required delay when waking from SLEEP and all IDLE modes. This delay runs concurrently with any other required delays (see Section 3.3).

PIC18F1220/1320

3.5.2 EXIT BY RESET

Normally, the device is held in RESET by the Oscillator Start-up Timer (OST) until the primary clock (defined in Configuration Register 1H) becomes ready. At that time, the OSTS bit is set, and the device begins executing code.

Code execution can begin before the primary clock becomes ready. If either the Two-Speed Start-up (see Section 19.3), or Fail-Safe Clock Monitor (see Section 19.4) are enabled in Configuration Register 1H, the device may begin execution as soon as the RESET source has cleared. Execution is clocked by the INTOSC multiplexer driven by the internal oscillator block. Since the OSCCON register is cleared following all RESETS, the INTRC clock source is selected. A higher speed clock may be selected by modifying the IRCF bits in the OSCCON register. Execution is clocked by the internal oscillator block until either the primary clock becomes ready, or a Power Managed mode is entered before the primary clock becomes ready; the primary clock is then shutdown.

3.5.3 EXIT BY WDT TIME-OUT

A WDT time-out will cause different actions, depending on which Power Managed mode the device is in when the time-out occurs.

If the device is not executing code (all IDLE modes and SLEEP mode), the time-out will result in a wake from the Power Managed mode (see Sections 3.2 through 3.4).

If the device is executing code (all RUN modes), the time-out will result in a WDT Reset (see Section 19.2, "Watchdog Timer (WDT)").

The WDT timer and postscaler are cleared by executing a SLEEP or CLRWDT instruction, the loss of a currently selected clock source (if the Fail-Safe Clock Monitor is enabled), and modifying the IRCF bits in the OSCCON register if the internal oscillator block is the system clock source.

3.5.4 EXIT WITHOUT AN OSCILLATOR START-UP DELAY

Certain exits from Power Managed modes do not invoke the OST at all. These are:

- PRI_IDLE mode, where the primary clock source is not stopped; and
- the primary clock source is not any of LP, XT, HS or HSPLL modes.

In these cases, the primary clock source either does not require an oscillator start-up delay, since it is already running (PRI_IDLE), or normally does not require an oscillator start-up delay (RC, EC, and INTIO Oscillator modes).

However, a fixed delay (approximately 10 μ s) following the wake event is required when leaving SLEEP and IDLE modes. This delay is required for the CPU to prepare for execution. Instruction execution resumes on the first clock cycle following this delay.

3.6 INTOSC Frequency Drift

The factory calibrates the internal oscillator block output (INTOSC) for 8 MHz (see Table 22.5). However, this frequency may drift as VDD or temperature changes, which can affect the controller operation in a variety of ways.

It is possible to adjust the INTOSC frequency by modifying the value in the OSCTUNE register (Register 2-1). This has the side effect that the INTRC clock source frequency is also affected. However, the features that use the INTRC source often do not require an exact frequency. These features include the Fail-Safe Clock Monitor, the Watchdog Timer, and the RC_RUN/RC_IDLE modes when the INTRC clock source is selected.

Being able to adjust the INTOSC requires knowing when an adjustment is required, in which direction it should be made, and in some cases, how large a change is needed. Three examples are shown below, but other techniques may be used.

3.6.1 EXAMPLE - USART

An adjustment may be indicated when the USART begins to generate framing errors, or receives data with errors while in Asynchronous mode. Framing errors indicate that the system clock frequency is too high – try decrementing the value in the OSCTUNE register to reduce the system clock frequency. Errors in data may suggest that the system clock speed is too low – increment OSCTUNE.

3.6.2 EXAMPLE – TIMERS

This technique compares system clock speed to some reference clock. Two timers may be used; one timer is clocked by the peripheral clock, while the other is clocked by a fixed reference source, such as the Timer1 oscillator.

Both timers are cleared, but the timer clocked by the reference generates interrupts. When an interrupt occurs, the internally clocked timer is read and both timers are cleared. If the internally clocked timer value is greater than expected, then the internal oscillator block is running too fast – decrement OSCTUNE.

3.6.3 EXAMPLE – CCP IN CAPTURE MODE

A CCP module can use free running Timer1 (or Timer3), clocked by the internal oscillator block and an external event with a known period (i.e., AC power frequency). The time of the first event is captured in the CCPRxH:CCPRxL registers, and is recorded for use later. When the second event causes a capture, the time of the first event is subtracted from the time of the second event. Since the period of the external event is known, the time difference between events can be calculated.

If the measured time is much greater than the calculated time, the internal oscillator block is running too fast – decrement OSCTUNE. If the measured time is much less than the calculated time, the internal oscillator block is running too slow – increment OSCTUNE.

PIC18F1220/1320

NOTES:

4.0 RESET

The PIC18F1220/1320 devices differentiate between various kinds of RESET:

- a) Power-on Reset (POR)
- b) $\overline{\text{MCLR}}$ Reset during normal operation
- c) $\overline{\text{MCLR}}$ Reset during SLEEP
- d) Watchdog Timer (WDT) Reset (during execution)
- e) Programmable Brown-out Reset (BOR)
- f) RESET Instruction
- g) Stack Full Reset
- h) Stack Underflow Reset

Most registers are unaffected by a RESET. Their status is unknown on POR and unchanged by all other RESETS. The other registers are forced to a "RESET state", depending on the type of RESET that occurred.

Most registers are not affected by a WDT wake-up, since this is viewed as the resumption of normal operation. Status bits from the RCON register (Register 4-1), RI, TO, PD, POR and BOR, are set or cleared differently in different RESET situations, as indicated in Table 4-2. These bits are used in software to determine the nature of the RESET. See Table 4-3 for a full description of the RESET states of all registers.

A simplified block diagram of the On-Chip Reset Circuit is shown in Figure 4-1.

The Enhanced MCU devices have a $\overline{\text{MCLR}}$ noise filter in the $\overline{\text{MCLR}}$ Reset path. The filter will detect and ignore small pulses.

The $\overline{\text{MCLR}}$ pin is not driven low by any internal RESETS, including the WDT.

The $\overline{\text{MCLR}}$ input provided by the $\overline{\text{MCLR}}$ pin can be disabled with the MCLRE bit in Configuration Register 3H (CONFIG3H<7>).

FIGURE 4-1: SIMPLIFIED BLOCK DIAGRAM OF ON-CHIP RESET CIRCUIT

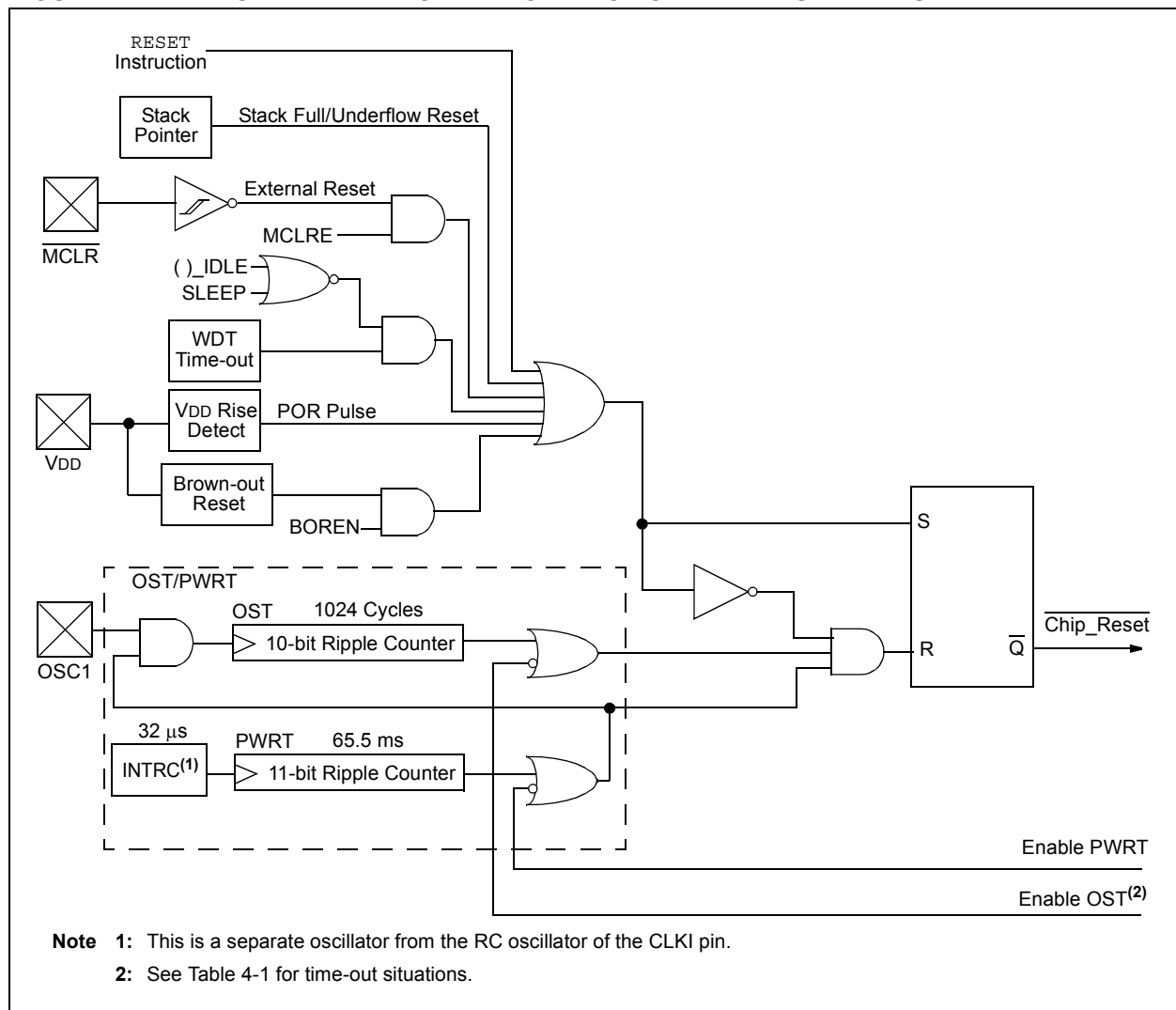

PIC18F1220/1320

4.1 Power-on Reset (POR)

A Power-on Reset pulse is generated on-chip when VDD rise is detected. To take advantage of the POR circuitry, just tie the $\overline{\text{MCLR}}$ pin through a resistor (1k to 10 k Ω) to VDD. This will eliminate external RC components usually needed to create a Power-on Reset delay. A minimum rise rate for VDD is specified (parameter D004). For a slow rise time, see Figure 4-2.

When the device starts normal operation (i.e., exits the RESET condition), device operating parameters (voltage, frequency, temperature, etc.) must be met to ensure operation. If these conditions are not met, the device must be held in RESET until the operating conditions are met.

FIGURE 4-2: EXTERNAL POWER-ON RESET CIRCUIT (FOR SLOW VDD POWER-UP)

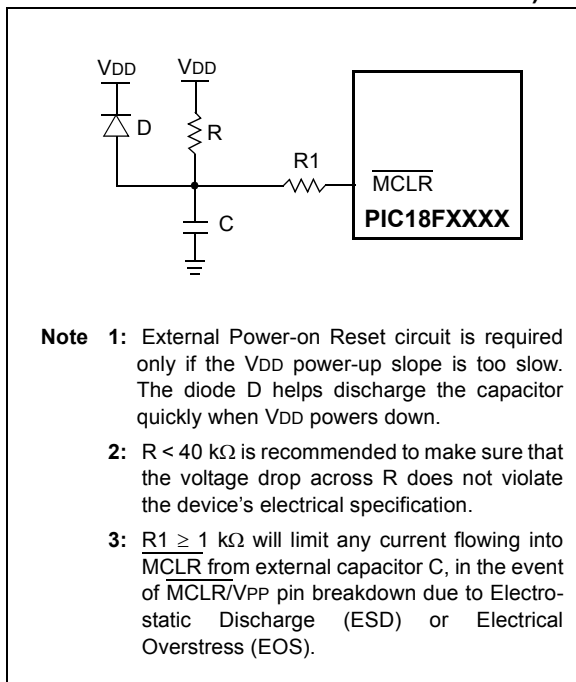

4.2 Power-up Timer (PWRT)

The Power-up Timer (PWRT) of the PIC18F1220/1320 is an 11-bit counter, which uses the INTRC source as the clock input. This yields a count of $2048 \times 32 \mu\text{s} = 65.6 \text{ ms}$. While the PWRT is counting, the device is held in RESET.

The power-up time delay will vary from chip-to-chip due to VDD, temperature and process variation. See DC parameter #33 for details.

The PWRT is enabled by clearing configuration bit PWRTEN .

4.3 Oscillator Start-up Timer (OST)

The Oscillator Start-up Timer (OST) provides a 1024 oscillator cycle (from OSC1 input) delay after the PWRT delay is over (parameter #33). This ensures that the crystal oscillator or resonator has started and stabilized.

The OST time-out is invoked only for XT, LP, HS and HSPLL modes, and only on Power-on Reset, or on exit from most Low Power modes.

4.4 PLL Lock Time-out

With the PLL enabled in its PLL mode, the time-out sequence following a Power-on Reset is slightly different from other Oscillator modes. A portion of the Power-up Timer is used to provide a fixed time-out that is sufficient for the PLL to lock to the main oscillator frequency. This PLL lock time-out (TPLL) is typically 2 ms and follows the Oscillator Start-up Time-out (OST).

4.5 Brown-out Reset (BOR)

A configuration bit, BOREN, can disable (if clear/programmed), or enable (if set) the Brown-out Reset circuitry. If VDD falls below VBOR (parameter D005) for greater than TBOR (parameter #35), the brown-out situation will reset the chip. A RESET may not occur if VDD falls below VBOR for less than TBOR. The chip will remain in Brown-out Reset until VDD rises above VBOR. If the Power-up Timer is enabled, it will be invoked after VDD rises above VBOR; it then will keep the chip in RESET for an additional time delay TPWRT (parameter #33). If VDD drops below VBOR while the Power-up Timer is running, the chip will go back into a Brown-out Reset and the Power-up Timer will be initialized. Once VDD rises above VBOR, the Power-up Timer will execute the additional time delay. Enabling BOR Reset does not automatically enable the PWRT.

4.6 Time-out Sequence

On power-up, the time-out sequence is as follows: First, after the POR pulse has cleared, PWRT time-out is invoked (if enabled). Then, the OST is activated. The total time-out will vary based on oscillator configuration and the status of the PWRT. For example, in RC mode with the PWRT disabled, there will be no time-out at all. Figure 4-3, Figure 4-4, Figure 4-5, Figure 4-6 and Figure 4-7 depict time-out sequences on power-up.

Since the time-outs occur from the POR pulse, if $\overline{\text{MCLR}}$ is kept low long enough, all time-outs will expire. Bringing $\overline{\text{MCLR}}$ high will begin execution immediately (Figure 4-5). This is useful for testing purposes or to synchronize more than one PIC18FXXXX device operating in parallel.

Table 4-2 shows the RESET conditions for some Special Function Registers, while Table 4-3 shows the RESET conditions for all the registers.

TABLE 4-1: TIME-OUT IN VARIOUS SITUATIONS

Oscillator Configuration	Power-up ⁽²⁾ and Brown-out		Exit from Low Power Mode
	PWRTEN = 0	PWRTEN = 1	
HSPLL	66 ms ⁽¹⁾ + 1024 TOSC + 2 ms ⁽²⁾	1024 TOSC + 2 ms ⁽²⁾	1024 TOSC + 2 ms ⁽²⁾
HS, XT, LP	66 ms ⁽¹⁾ + 1024 TOSC	1024 TOSC	1024 TOSC
EC, ECIO	66 ms ⁽¹⁾	5-10 μs ⁽³⁾	5-10 μs ⁽³⁾
RC, RCIO	66 ms ⁽¹⁾	5-10 μs ⁽³⁾	5-10 μs ⁽³⁾
INTIO1, INTIO2	66 ms ⁽¹⁾	5-10 μs ⁽³⁾	5-10 μs ⁽³⁾

- Note 1:** 66 ms (65.5 ms) is the nominal Power-up Timer (PWRT) delay.
Note 2: 2 ms is the nominal time required for the 4x PLL to lock.
Note 3: The program memory bias start-up time is always invoked on POR, wake-up from SLEEP, or on any exit from Power Managed mode that disables the CPU and instruction execution.

REGISTER 4-1: RCON REGISTER BITS AND POSITIONS

R/W-0	U-0	U-0	R/W-1	R/W-1	R/W-1	R/W-1	R/W-1	
IPEN	—	—	RI	TO	PD	POR	BOR	
bit 7								bit 0

Note: Refer to Section 5.14 (page 58) for bit definitions.

TABLE 4-2: STATUS BITS, THEIR SIGNIFICANCE AND THE INITIALIZATION CONDITION FOR RCON REGISTER

Condition	Program Counter	RCON Register	RI	TO	PD	POR	BOR	STKFUL	STKUNF
Power-on Reset	0000h	0--1 1100	1	1	1	0	0	0	0
RESET Instruction	0000h	0--0 uuuu	0	u	u	u	u	u	u
Brown-out	0000h	0--1 11u-	1	1	1	u	0	u	u
MCLR during Power Managed RUN modes	0000h	0--u 1uuu	u	1	u	u	u	u	u
MCLR during Power Managed IDLE modes and SLEEP	0000h	0--u 10uu	u	1	0	u	u	u	u
WDT Time-out during Full Power or Power Managed RUN	0000h	0--u 0uuu	u	0	u	u	u	u	u
MCLR during Full Power Execution								u	u
Stack Full Reset (STVREN = 1)	0000h	0--u uuuu	u	u	u	u	u	1	u
Stack Underflow RESET (STVREN = 1)								u	1
Stack Underflow Error (not an actual RESET, STVREN = 0)	0000h	u--u uuuu	u	u	u	u	u	u	1
WDT Time-out during Power Managed IDLE or SLEEP	PC + 2	u--u 00uu	u	0	0	u	u	u	u
Interrupt Exit from Power Managed modes	PC + 2	u--u u0uu	u	u	0	u	u	u	u

Legend: u = unchanged, x = unknown, - = unimplemented bit, read as '0'

Note: When the wake-up is due to an interrupt and the GIEH or GIEL bits are set, the PC is loaded with the interrupt vector (0x000008h or 0x000018h).

PIC18F1220/1320

TABLE 4-3: INITIALIZATION CONDITIONS FOR ALL REGISTERS

Register	Applicable Devices		Power-on Reset, Brown-out Reset	MCLR Resets WDT Reset RESET Instruction Stack Resets	Wake-up via WDT or Interrupt
TOSU	1220	1320	---0 0000	---0 0000	---0 uuuu ⁽³⁾
TOSH	1220	1320	0000 0000	0000 0000	uuuu uuuu ⁽³⁾
TOSL	1220	1320	0000 0000	0000 0000	uuuu uuuu ⁽³⁾
STKPTR	1220	1320	00-0 0000	00-0 0000	uu-u uuuu ⁽³⁾
PCLATU	1220	1320	---0 0000	---0 0000	---u uuuu
PCLATH	1220	1320	0000 0000	0000 0000	uuuu uuuu
PCL	1220	1320	0000 0000	0000 0000	PC + 2 ⁽²⁾
TBLPTRU	1220	1320	--00 0000	--00 0000	--uu uuuu
TBLPTRH	1220	1320	0000 0000	0000 0000	uuuu uuuu
TBLPTRL	1220	1320	0000 0000	0000 0000	uuuu uuuu
TABLAT	1220	1320	0000 0000	0000 0000	uuuu uuuu
PRODH	1220	1320	xxxx xxxx	uuuu uuuu	uuuu uuuu
PRODL	1220	1320	xxxx xxxx	uuuu uuuu	uuuu uuuu
INTCON	1220	1320	0000 000x	0000 000u	uuuu uuuu ⁽¹⁾
INTCON2	1220	1320	1111 -1-1	1111 -1-1	uuuu -u-u ⁽¹⁾
INTCON3	1220	1320	11-0 0-00	11-0 0-00	uu-u u-uu ⁽¹⁾
INDF0	1220	1320	N/A	N/A	N/A
POSTINC0	1220	1320	N/A	N/A	N/A
POSTDEC0	1220	1320	N/A	N/A	N/A
PREINC0	1220	1320	N/A	N/A	N/A
PLUSW0	1220	1320	N/A	N/A	N/A
FSR0H	1220	1320	---- 0000	---- 0000	---- uuuu
FSR0L	1220	1320	xxxx xxxx	uuuu uuuu	uuuu uuuu
WREG	1220	1320	xxxx xxxx	uuuu uuuu	uuuu uuuu
INDF1	1220	1320	N/A	N/A	N/A
POSTINC1	1220	1320	N/A	N/A	N/A
POSTDEC1	1220	1320	N/A	N/A	N/A
PREINC1	1220	1320	N/A	N/A	N/A
PLUSW1	1220	1320	N/A	N/A	N/A

Legend: u = unchanged, x = unknown, - = unimplemented bit, read as '0', q = value depends on condition.

Shaded cells indicate conditions do not apply for the designated device.

Note 1: One or more bits in the INTCONx or PIRx registers will be affected (to cause wake-up).

2: When the wake-up is due to an interrupt and the GIEL or GIEH bit is set, the PC is loaded with the interrupt vector (0008h or 0018h).

3: When the wake-up is due to an interrupt and the GIEL or GIEH bit is set, the TOSU, TOSH and TOSL are updated with the current value of the PC. The STKPTR is modified to point to the next location in the hardware stack.

4: See Table 4-2 for RESET value for specific condition.

5: Bits 6 and 7 of PORTA, LATA, and TRISA are enabled, depending on the Oscillator mode selected. When not enabled as PORTA pins, they are disabled and read '0'.

6: Bit 5 of PORTA is enabled if MCLR is disabled.

TABLE 4-3: INITIALIZATION CONDITIONS FOR ALL REGISTERS (CONTINUED)

Register	Applicable Devices		Power-on Reset, Brown-out Reset	MCLR Resets WDT Reset RESET Instruction Stack Resets	Wake-up via WDT or Interrupt
FSR1H	1220	1320	---- 0000	---- 0000	---- uuuu
FSR1L	1220	1320	xxxx xxxx	uuuu uuuu	uuuu uuuu
BSR	1220	1320	---- 0000	---- 0000	---- uuuu
INDF2	1220	1320	N/A	N/A	N/A
POSTINC2	1220	1320	N/A	N/A	N/A
POSTDEC2	1220	1320	N/A	N/A	N/A
PREINC2	1220	1320	N/A	N/A	N/A
PLUSW2	1220	1320	N/A	N/A	N/A
FSR2H	1220	1320	---- 0000	---- 0000	---- uuuu
FSR2L	1220	1320	xxxx xxxx	uuuu uuuu	uuuu uuuu
STATUS	1220	1320	---x xxxx	---u uuuu	---u uuuu
TMR0H	1220	1320	0000 0000	0000 0000	uuuu uuuu
TMR0L	1220	1320	xxxx xxxx	uuuu uuuu	uuuu uuuu
T0CON	1220	1320	1111 1111	1111 1111	uuuu uuuu
OSCCON	1220	1320	0000 q000	0000 00q0	uuuu uuqu
LVDCON	1220	1320	--00 0101	--00 0101	--uu uuuu
WDTCON	1220	1320	---- ---0	---- ---0	---- ---u
RCON ⁽⁴⁾	1220	1320	0--1 11q0	0--q qquu	u--u qquu
TMR1H	1220	1320	xxxx xxxx	uuuu uuuu	uuuu uuuu
TMR1L	1220	1320	xxxx xxxx	uuuu uuuu	uuuu uuuu
T1CON	1220	1320	0000 0000	u0uu uuuu	uuuu uuuu
TMR2	1220	1320	0000 0000	0000 0000	uuuu uuuu
PR2	1220	1320	1111 1111	1111 1111	1111 1111
T2CON	1220	1320	-000 0000	-000 0000	-uuu uuuu

Legend: u = unchanged, x = unknown, - = unimplemented bit, read as '0', q = value depends on condition.

Shaded cells indicate conditions do not apply for the designated device.

Note 1: One or more bits in the INTCONx or PIRx registers will be affected (to cause wake-up).

2: When the wake-up is due to an interrupt and the GIEL or GIEH bit is set, the PC is loaded with the interrupt vector (0008h or 0018h).

3: When the wake-up is due to an interrupt and the GIEL or GIEH bit is set, the TOSU, TOSH and TOSL are updated with the current value of the PC. The STKPTR is modified to point to the next location in the hardware stack.

4: See Table 4-2 for RESET value for specific condition.

5: Bits 6 and 7 of PORTA, LATA, and TRISA are enabled, depending on the Oscillator mode selected. When not enabled as PORTA pins, they are disabled and read '0'.

6: Bit 5 of PORTA is enabled if MCLR is disabled.

PIC18F1220/1320

TABLE 4-3: INITIALIZATION CONDITIONS FOR ALL REGISTERS (CONTINUED)

Register	Applicable Devices		Power-on Reset, Brown-out Reset	MCLR Resets WDT Reset RESET Instruction Stack Resets	Wake-up via WDT or Interrupt
ADRESH	1220	1320	xxxx xxxx	uuuu uuuu	uuuu uuuu
ADRESL	1220	1320	xxxx xxxx	uuuu uuuu	uuuu uuuu
ADCON0	1220	1320	00-0 0000	00-0 0000	uu-u uuuu
ADCON1	1220	1320	-000 0000	-000 0000	-uuu uuuu
ADCON2	1220	1320	0-00 0000	0-00 0000	u-uu uuuu
CCPR1H	1220	1320	xxxx xxxx	uuuu uuuu	uuuu uuuu
CCPR1L	1220	1320	xxxx xxxx	uuuu uuuu	uuuu uuuu
CCP1CON	1220	1320	0000 0000	0000 0000	uuuu uuuu
PWM1CON	1220	1320	0000 0000	0000 0000	uuuu uuuu
ECCPAS	1220	1320	0000 0000	0000 0000	uuuu uuuu
TMR3H	1220	1320	xxxx xxxx	uuuu uuuu	uuuu uuuu
TMR3L	1220	1320	xxxx xxxx	uuuu uuuu	uuuu uuuu
T3CON	1220	1320	0000 0000	uuuu uuuu	uuuu uuuu
SPBRGH	1220	1320	0000 0000	0000 0000	uuuu uuuu
SPBRG	1220	1320	0000 0000	0000 0000	uuuu uuuu
RCREG	1220	1320	0000 0000	0000 0000	uuuu uuuu
TXREG	1220	1320	0000 0000	0000 0000	uuuu uuuu
TXSTA	1220	1320	0000 0010	0000 0010	uuuu uuuu
RCSTA	1220	1320	0000 000x	0000 000x	uuuu uuuu
BAUDCTL	1220	1320	-1-1 0-00	-1-1 0-00	-u-u u-uu
EEADR	1220	1320	0000 0000	0000 0000	uuuu uuuu
EEDATA	1220	1320	0000 0000	0000 0000	uuuu uuuu
EECON1	1220	1320	xx-0 x000	uu-0 u000	uu-0 u000
EECON2	1220	1320	0000 0000	0000 0000	0000 0000

Legend: u = unchanged, x = unknown, - = unimplemented bit, read as '0', q = value depends on condition.

Shaded cells indicate conditions do not apply for the designated device.

- Note 1:** One or more bits in the INTCONx or PIRx registers will be affected (to cause wake-up).
- 2:** When the wake-up is due to an interrupt and the GIEL or GIEH bit is set, the PC is loaded with the interrupt vector (0008h or 0018h).
- 3:** When the wake-up is due to an interrupt and the GIEL or GIEH bit is set, the TOSU, TOSH and TOSL are updated with the current value of the PC. The STKPTR is modified to point to the next location in the hardware stack.
- 4:** See Table 4-2 for RESET value for specific condition.
- 5:** Bits 6 and 7 of PORTA, LATA, and TRISA are enabled, depending on the Oscillator mode selected. When not enabled as PORTA pins, they are disabled and read '0'.
- 6:** Bit 5 of PORTA is enabled if MCLR is disabled.

TABLE 4-3: INITIALIZATION CONDITIONS FOR ALL REGISTERS (CONTINUED)

Register	Applicable Devices		Power-on Reset, Brown-out Reset	MCLR Resets WDT Reset RESET Instruction Stack Resets	Wake-up via WDT or Interrupt
IPR2	1220	1320	1--1 -11-	1--1 -11-	u--u -uu-
PIR2	1220	1320	0--0 -00-	0--0 -00-	u--u -uu-(1)
PIE2	1220	1320	0--0 -00-	0--0 -00-	u--u -uu-
IPR1	1220	1320	-111 -111	-111 -111	-uuu -uuu
PIR1	1220	1320	-000 -000	-000 -000	-uuu -uuu(1)
PIE1	1220	1320	-000 -000	-000 -000	-uuu -uuu
OSCTUNE	1220	1320	--00 0000	--00 0000	--uu uuuu
TRISB	1220	1320	1111 1111	1111 1111	uuuu uuuu
TRISA(5)	1220	1320	11-1 1111(5)	11-1 1111(5)	uu-u uuuu(5)
LATB	1220	1320	xxxx xxxx	uuuu uuuu	uuuu uuuu
LATA(5)	1220	1320	xx-x xxxx(5)	uu-u uuuu(5)	uu-u uuuu(5)
PORTB	1220	1320	xxxx xxxx	uuuu uuuu	uuuu uuuu
PORTA(5,6)	1220	1320	xx0x 0000(5,6)	uu0u 0000(5,6)	uuuu uuuu(5,6)

Legend: u = unchanged, x = unknown, - = unimplemented bit, read as '0', q = value depends on condition.
Shaded cells indicate conditions do not apply for the designated device.

- Note 1:** One or more bits in the INTCONx or PIRx registers will be affected (to cause wake-up).
- 2:** When the wake-up is due to an interrupt and the GIEL or GIEH bit is set, the PC is loaded with the interrupt vector (0008h or 0018h).
- 3:** When the wake-up is due to an interrupt and the GIEL or GIEH bit is set, the TOSU, TOSH and TOSL are updated with the current value of the PC. The STKPTR is modified to point to the next location in the hardware stack.
- 4:** See Table 4-2 for RESET value for specific condition.
- 5:** Bits 6 and 7 of PORTA, LATA, and TRISA are enabled, depending on the Oscillator mode selected. When not enabled as PORTA pins, they are disabled and read '0'.
- 6:** Bit 5 of PORTA is enabled if MCLR is disabled.

PIC18F1220/1320

FIGURE 4-3: TIME-OUT SEQUENCE ON POWER-UP ($\overline{\text{MCLR}}$ TIED TO V_{DD} , V_{DD} RISE < T_{PWRT})

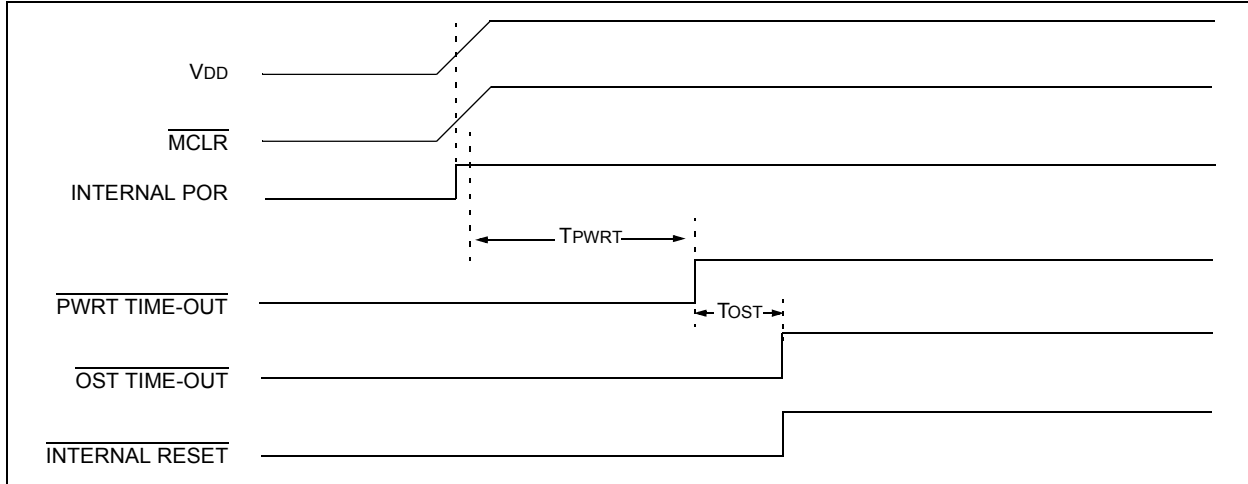

FIGURE 4-4: TIME-OUT SEQUENCE ON POWER-UP ($\overline{\text{MCLR}}$ NOT TIED TO V_{DD}): CASE 1

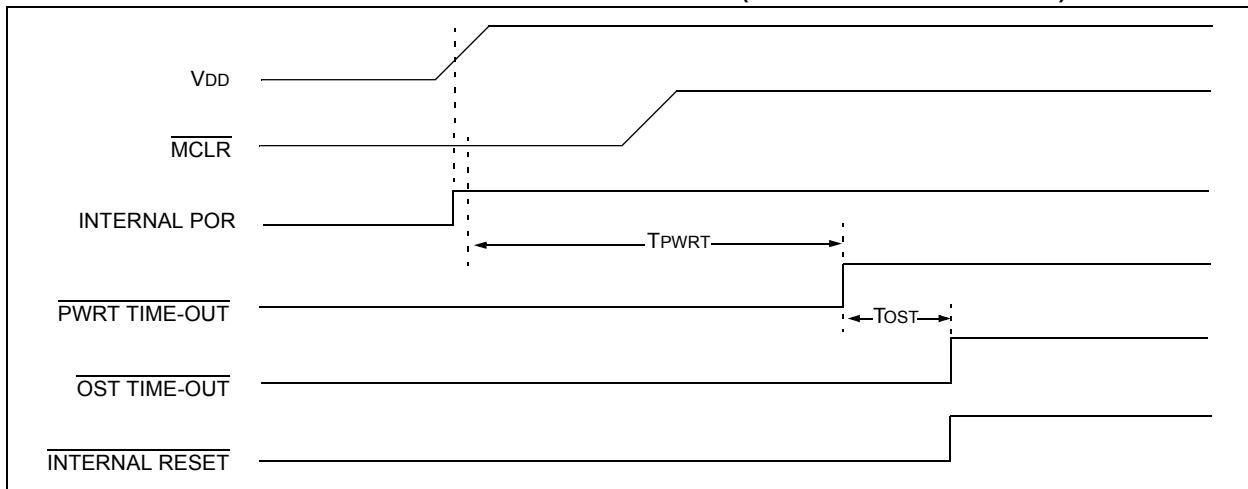

FIGURE 4-5: TIME-OUT SEQUENCE ON POWER-UP ($\overline{\text{MCLR}}$ NOT TIED TO V_{DD}): CASE 2

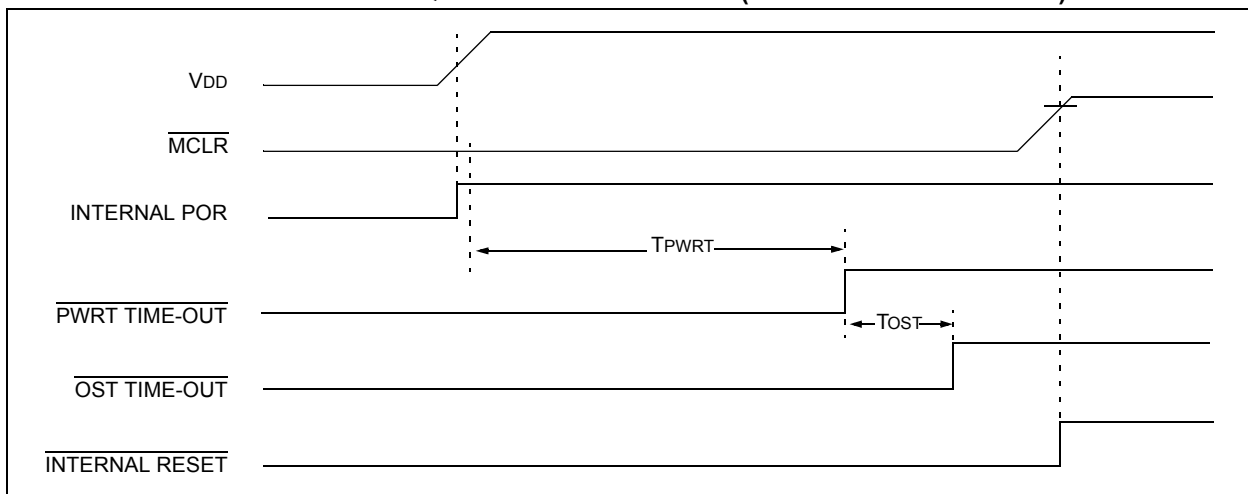

FIGURE 4-6: SLOW RISE TIME ($\overline{\text{MCLR}}$ TIED TO V_{DD} , V_{DD} RISE $>$ T_{PWRT})

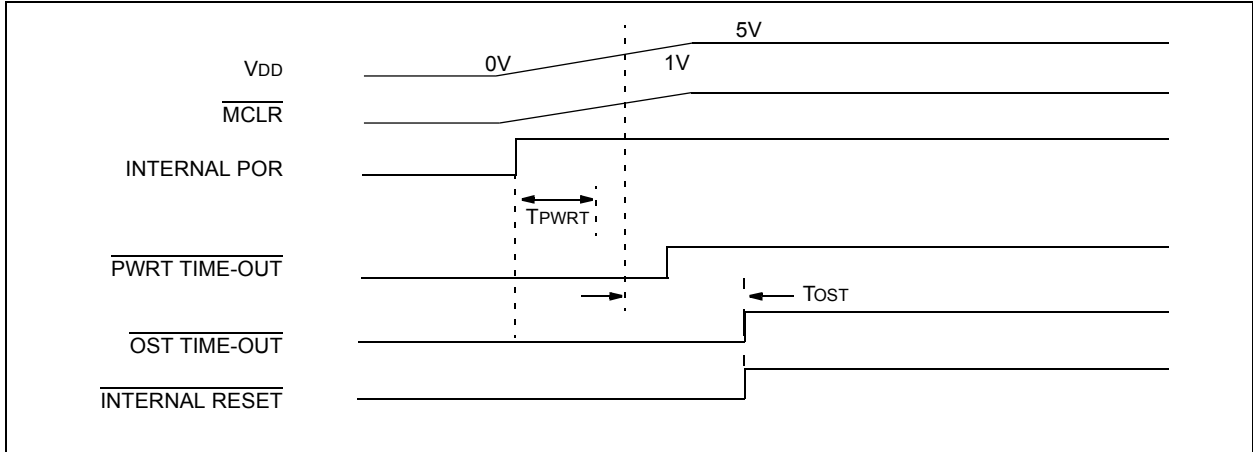
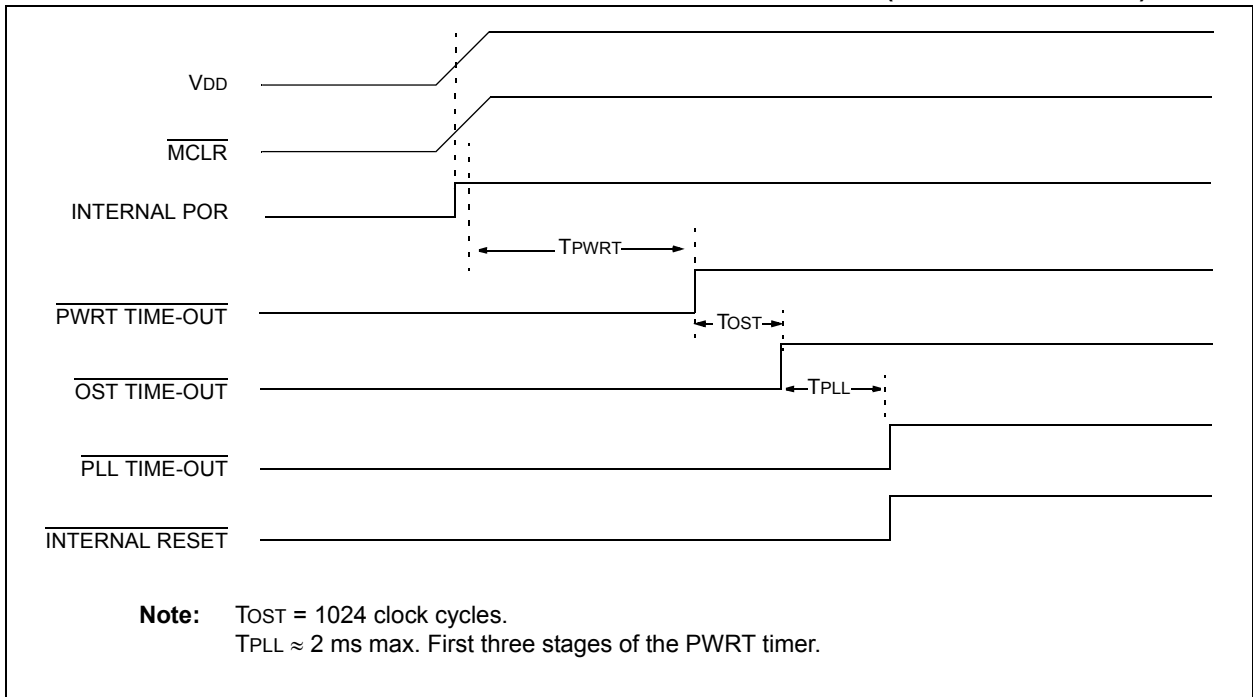

FIGURE 4-7: TIME-OUT SEQUENCE ON POR W/ PLL ENABLED ($\overline{\text{MCLR}}$ TIED TO V_{DD})



PIC18F1220/1320

NOTES:

5.0 MEMORY ORGANIZATION

There are three memory types in Enhanced MCU devices. These memory types are:

- Program Memory
- Data RAM
- Data EEPROM

Data and program memory use separate busses, which allows for concurrent access of these types.

Additional detailed information for FLASH program memory and Data EEPROM is provided in Section 6.0 and Section 7.0, respectively.

5.1 Program Memory Organization

A 21-bit program counter is capable of addressing the 2-Mbyte program memory space. Accessing a location between the physically implemented memory and the 2-Mbyte address will cause a read of all '0's (a NOP instruction).

The PIC18F1220 has 4 Kbytes of FLASH memory and can store up to 2,048 single word instructions.

The PIC18F1320 has 8 Kbytes of FLASH memory and can store up to 4,096 single word instructions.

The RESET vector address is at 0000h and the interrupt vector addresses are at 0008h and 0018h.

The Program Memory Maps for the PIC18F1220 and PIC18F1320 devices are shown in Figure 5-1 and Figure 5-2, respectively.

FIGURE 5-1: PROGRAM MEMORY MAP AND STACK FOR PIC18F1220

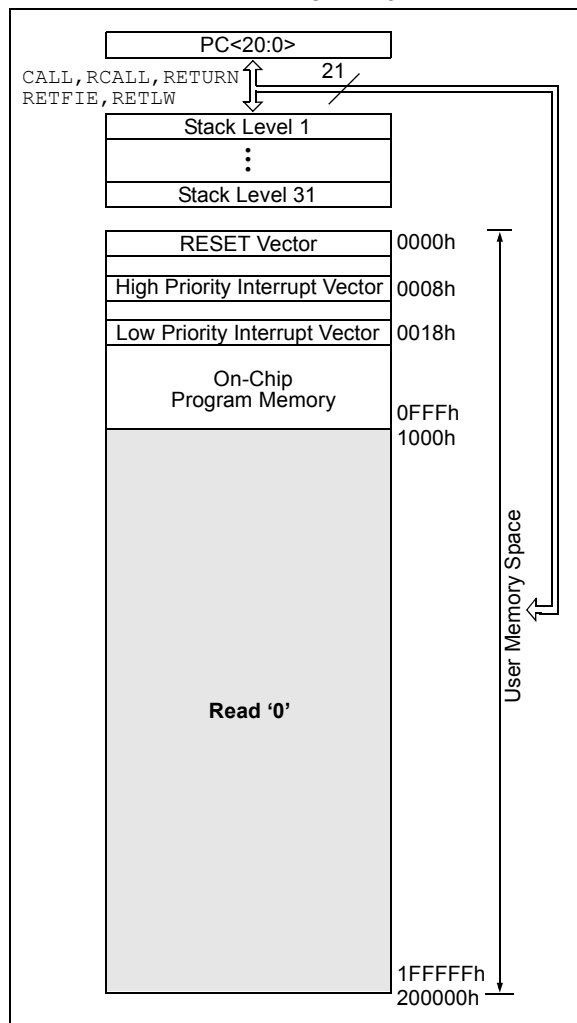
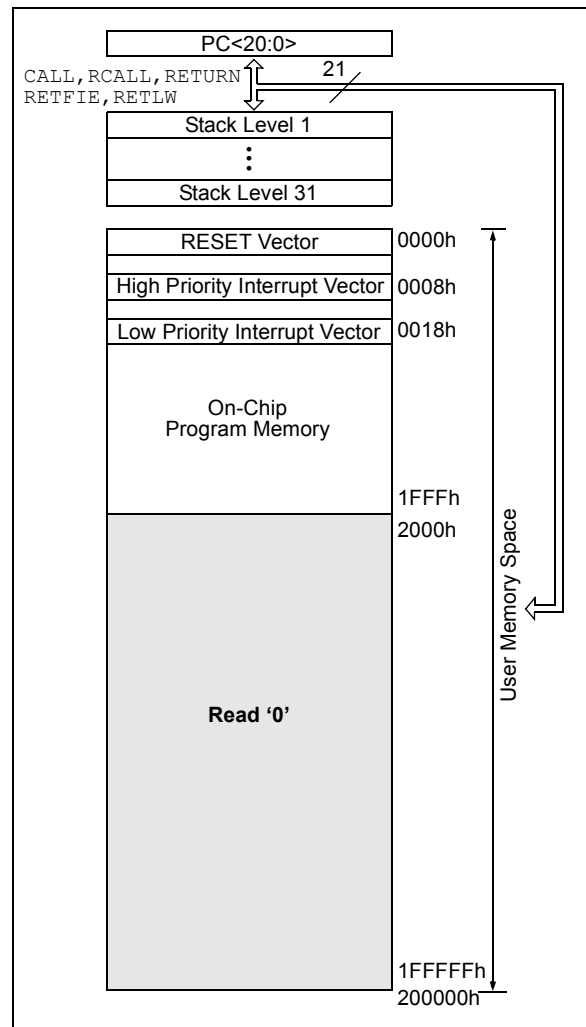

FIGURE 5-2: PROGRAM MEMORY MAP AND STACK FOR PIC18F1320



PIC18F1220/1320

5.2 Return Address Stack

The return address stack allows any combination of up to 31 program calls and interrupts to occur. The PC (Program Counter) is pushed onto the stack when a `CALL` or `RCALL` instruction is executed, or an interrupt is Acknowledged. The PC value is pulled off the stack on a `RETURN`, `RETLW` or a `RETFIE` instruction. `PCLATU` and `PCLATH` are not affected by any of the `RETURN` or `CALL` instructions.

The stack operates as a 31-word by 21-bit RAM and a 5-bit stack pointer, with the stack pointer initialized to `00000B` after all RESETS. There is no RAM associated with stack pointer `00000B`. This is only a RESET value. During a `CALL` type instruction, causing a push onto the stack, the stack pointer is first incremented and the RAM location pointed to by the stack pointer is written with the contents of the PC (already pointing to the instruction following the call). During a `RETURN` type instruction, causing a pop from the stack, the contents of the RAM location pointed to by the `STKPTR` are transferred to the PC and then the stack pointer is decremented.

The stack space is not part of either program or data space. The stack pointer is readable and writable, and the address on the top of the stack is readable and writable through the top-of-stack special file registers. Data can also be pushed to, or popped from, the stack using the top-of-stack SFRs. Status bits indicate if the stack is full, has overflowed or underflowed.

5.2.1 TOP-OF-STACK ACCESS

The top of the stack is readable and writable. Three register locations, `TOSU`, `TOSH` and `TOSL` hold the contents of the stack location pointed to by the `STKPTR` register (Figure 5-3). This allows users to implement a software stack if necessary. After a `CALL`, `RCALL` or interrupt, the software can read the pushed value by reading the `TOSU`, `TOSH` and `TOSL` registers. These values can be placed on a user defined software stack. At return time, the software can replace the `TOSU`, `TOSH` and `TOSL` and do a return.

The user must disable the global interrupt enable bits while accessing the stack to prevent inadvertent stack corruption.

5.2.2 RETURN STACK POINTER (STKPTR)

The `STKPTR` register (Register 5-1) contains the stack pointer value, the `STKFUL` (stack full) status bit, and the `STKUNF` (stack underflow) status bits. The value of the stack pointer can be 0 through 31. The stack pointer increments before values are pushed onto the stack and decrements after values are popped off the stack. At RESET, the stack pointer value will be zero. The user may read and write the stack pointer value. This feature can be used by a Real-Time Operating System for return stack maintenance.

After the PC is pushed onto the stack 31 times (without popping any values off the stack), the `STKFUL` bit is set. The `STKFUL` bit is cleared by software or by a POR.

The action that takes place when the stack becomes full depends on the state of the `STVREN` (Stack Overflow Reset Enable) configuration bit. (Refer to Section 19.1 for a description of the device configuration bits.) If `STVREN` is set (default), the 31st push will push the `(PC + 2)` value onto the stack, set the `STKFUL` bit, and reset the device. The `STKFUL` bit will remain set and the stack pointer will be set to zero.

If `STVREN` is cleared, the `STKFUL` bit will be set on the 31st push and the stack pointer will increment to 31. Any additional pushes will not overwrite the 31st push, and `STKPTR` will remain at 31.

When the stack has been popped enough times to unload the stack, the next pop will return a value of zero to the PC and sets the `STKUNF` bit, while the stack pointer remains at zero. The `STKUNF` bit will remain set until cleared by software or a POR occurs.

Note: Returning a value of zero to the PC on an underflow has the effect of vectoring the program to the RESET vector, where the stack conditions can be verified and appropriate actions can be taken. This is not the same as a RESET, as the contents of the SFRs are not affected.

FIGURE 5-3: RETURN ADDRESS STACK AND ASSOCIATED REGISTERS

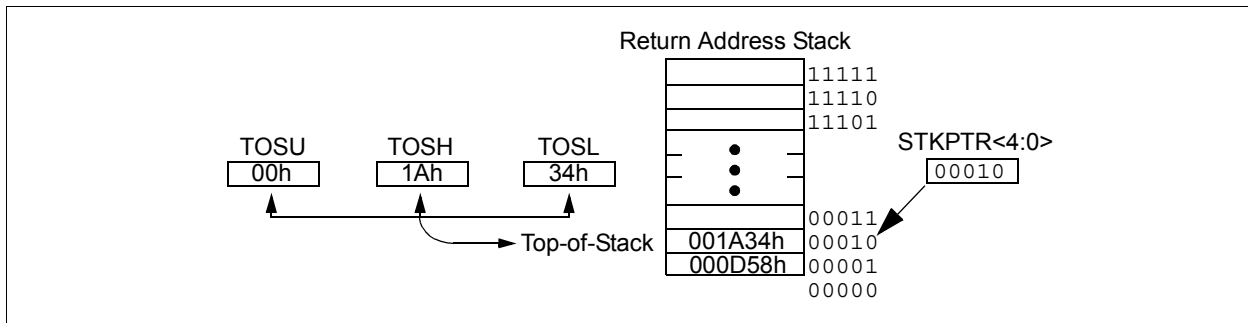

REGISTER 5-1: STKPTR REGISTER

R/C-0	R/C-0	U-0	R/W-0	R/W-0	R/W-0	R/W-0	R/W-0	
STKFUL	STKUNF	—	SP4	SP3	SP2	SP1	SP0	
bit 7								bit 0

- bit 7⁽¹⁾ **STKFUL:** Stack Full Flag bit
1 = Stack became full or overflowed
0 = Stack has not become full or overflowed
- bit 6⁽¹⁾ **STKUNF:** Stack Underflow Flag bit
1 = Stack underflow occurred
0 = Stack underflow did not occur
- bit 5 **Unimplemented:** Read as '0'
- bit 4-0 **SP4:SP0:** Stack Pointer Location bits

Note 1: Bit 7 and bit 6 are cleared by user software or by a POR.

Legend:

R = Readable bit	W = Writable bit	U = Unimplemented	C = Clearable only bit
- n = Value at POR	'1' = Bit is set	'0' = Bit is cleared	x = Bit is unknown

5.2.3 PUSH AND POP INSTRUCTIONS

Since the Top-of-Stack (TOS) is readable and writable, the ability to push values onto the stack and pull values off the stack, without disturbing normal program execution, is a desirable option. To push the current PC value onto the stack, a `PUSH` instruction can be executed. This will increment the stack pointer and load the current PC value onto the stack. `TOSU`, `TOSH` and `TOSL` can then be modified to place data or a return address on the stack.

The ability to pull the TOS value off of the stack and replace it with the value that was previously pushed onto the stack, without disturbing normal execution, is achieved by using the `POP` instruction. The `POP` instruction discards the current TOS by decrementing the stack pointer. The previous value pushed onto the stack then becomes the TOS value.

5.2.4 STACK FULL/UNDERFLOW RESETS

These RESETS are enabled by programming the `STVREN` bit in Configuration Register 4L. When the `STVREN` bit is cleared, a full or underflow condition will set the appropriate `STKFUL` or `STKUNF` bit, but not cause a device RESET. When the `STVREN` bit is set, a full or underflow condition will set the appropriate `STKFUL` or `STKUNF` bit and then cause a device RESET. The `STKFUL` or `STKUNF` bits are cleared by the user software or a POR Reset.

PIC18F1220/1320

5.3 Fast Register Stack

A “fast return” option is available for interrupts. A Fast Register Stack is provided for the STATUS, WREG and BSR registers and is only one in depth. The stack is not readable or writable and is loaded with the current value of the corresponding register when the processor vectors for an interrupt. The values in the registers are then loaded back into the working registers, if the RETFIE, FAST instruction is used to return from the interrupt.

All interrupt sources will push values into the stack registers. If both low and high priority interrupts are enabled, the stack registers cannot be used reliably to return from low priority interrupts. If a high priority interrupt occurs while servicing a low priority interrupt, the stack register values stored by the low priority interrupt will be overwritten. Users must save the key registers in software during a low priority interrupt.

If interrupt priority is not used, all interrupts may use the Fast Register Stack for returns from interrupt.

If no interrupts are used, the Fast Register Stack can be used to restore the STATUS, WREG and BSR registers at the end of a subroutine call. To use the Fast Register Stack for a subroutine call, a CALL LABEL, FAST instruction must be executed to save the STATUS, WREG, and BSR registers to the Fast Register Stack. A RETURN, FAST instruction is then executed to restore these registers from the Fast Register Stack.

Example 5-1 shows a source code example that uses the Fast Register Stack during a subroutine call and return.

EXAMPLE 5-1: FAST REGISTER STACK CODE EXAMPLE

```
CALL SUB1, FAST    ;STATUS, WREG, BSR
                  ;SAVED IN FAST REGISTER
                  ;STACK
                  .
                  .
SUB1              .
                  .
RETURN FAST      ;RESTORE VALUES SAVED
                  ;IN FAST REGISTER STACK
```

5.4 PCL, PCLATH and PCLATU

The program counter (PC) specifies the address of the instruction to fetch for execution. The PC is 21-bits wide. The low byte, known as the PCL register, is both readable and writable. The high byte, or PCH register, contains the PC<15:8> bits and is not directly readable or writable. Updates to the PCH register may be performed through the PCLATH register. The upper byte is called PCU. This register contains the PC<20:16> bits and is not directly readable or writable. Updates to the PCU register may be performed through the PCLATU register.

The contents of PCLATH and PCLATU will be transferred to the program counter by any operation that writes PCL. Similarly, the upper two bytes of the program counter will be transferred to PCLATH and PCLATU by an operation that reads PCL. This is useful for computed offsets to the PC (see Section 5.8.1).

The PC addresses bytes in the program memory. To prevent the PC from becoming misaligned with word instructions, the LSB of PCL is fixed to a value of '0'. The PC increments by 2 to address sequential instructions in the program memory.

The CALL, RCALL, GOTO and program branch instructions write to the program counter directly. For these instructions, the contents of PCLATH and PCLATU are not transferred to the program counter.

5.5 Clocking Scheme/Instruction Cycle

The clock input (from OSC1) is internally divided by four to generate four non-overlapping quadrature clocks, namely Q1, Q2, Q3 and Q4. Internally, the program counter (PC) is incremented every Q1, the instruction is fetched from the program memory and latched into the instruction register in Q4. The instruction is decoded and executed during the following Q1 through Q4. The clocks and instruction execution flow are shown in Figure 5-4.

5.6 Instruction Flow/Pipelining

An "Instruction Cycle" consists of four Q cycles (Q1, Q2, Q3 and Q4). The instruction fetch and execute are pipelined such that fetch takes one instruction cycle, while decode and execute takes another instruction cycle. However, due to the pipelining, each instruction effectively executes in one cycle. If an instruction causes the program counter to change (e.g., GOTO), then two cycles are required to complete the instruction (Example 5-2).

A fetch cycle begins with the program counter (PC) incrementing in Q1.

In the execution cycle, the fetched instruction is latched into the "Instruction Register" (IR) in cycle Q1. This instruction is then decoded and executed during the Q2, Q3, and Q4 cycles. Data memory is read during Q2 (operand read) and written during Q4 (destination write).

FIGURE 5-4: CLOCK/INSTRUCTION CYCLE

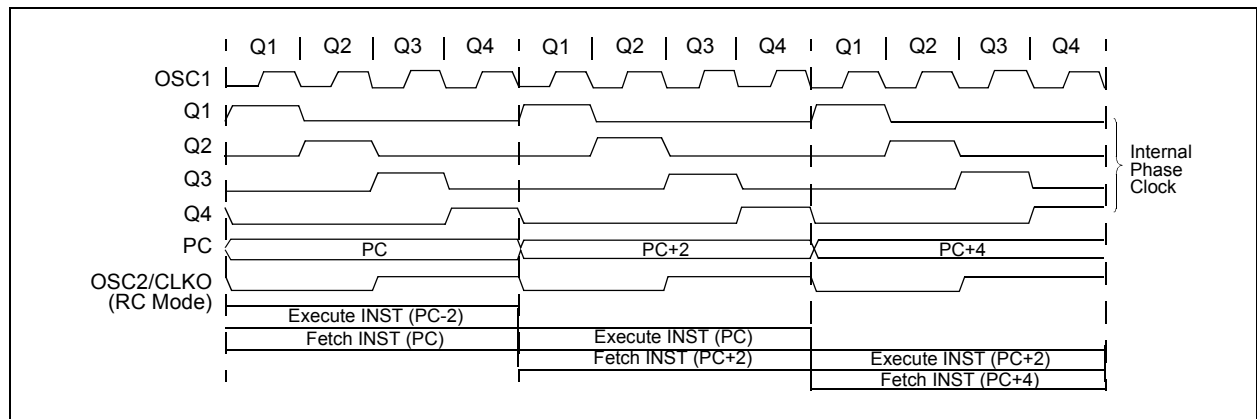

EXAMPLE 5-2: INSTRUCTION PIPELINE FLOW

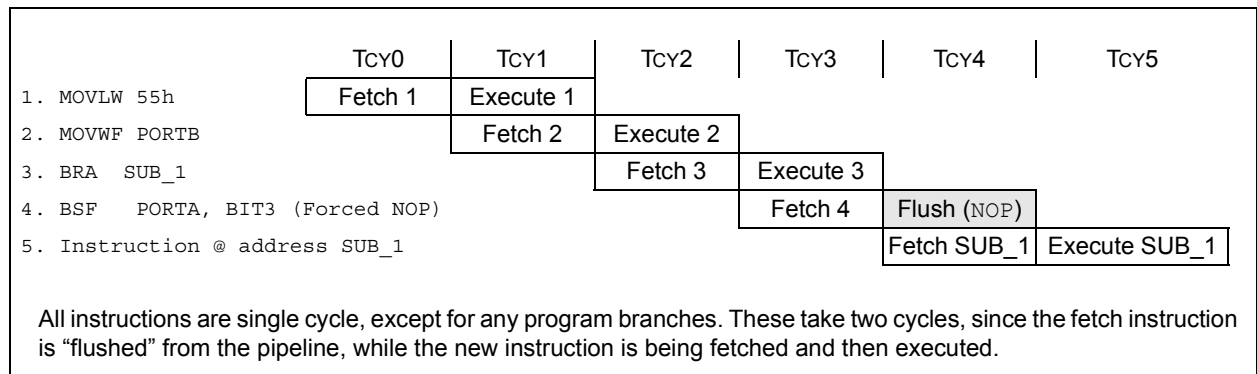

PIC18F1220/1320

5.7 Instructions in Program Memory

The program memory is addressed in bytes. Instructions are stored as two bytes or four bytes in program memory. The Least Significant Byte of an instruction word is always stored in a program memory location with an even address (LSB = 0). Figure 5-5 shows an example of how instruction words are stored in the program memory. To maintain alignment with instruction boundaries, the PC increments in steps of 2 and the LSB will always read '0' (see Section 5.4).

The CALL and GOTO instructions have the absolute program memory address embedded into the instruction. Since instructions are always stored on word boundaries, the data contained in the instruction is a word address. The word address is written to PC<20:1>, which accesses the desired byte address in program memory. Instruction #2 in Figure 5-5 shows how the instruction "GOTO 000006h" is encoded in the program memory. Program branch instructions, which encode a relative address offset, operate in the same manner. The offset value stored in a branch instruction represents the number of single word instructions that the PC will be offset by. Section 20.0 provides further details of the instruction set.

FIGURE 5-5: INSTRUCTIONS IN PROGRAM MEMORY

Program Memory Byte Locations →			LSB = 1	LSB = 0	Word Address ↓
			Instruction 1: MOVLW 055h	0Fh	55h
Instruction 2: GOTO 000006h	EFh	03h	000008h		
	F0h	00h	00000Ch		
Instruction 3: MOVFF 123h, 456h	C1h	23h	00000Eh		
	F4h	56h	000010h		
			000012h		
			000014h		

5.7.1 TWO-WORD INSTRUCTIONS

PIC18F1220/1320 devices have four two-word instructions: MOVFF, CALL, GOTO and LFSR. The second word of these instructions has the 4 MSBs set to '1's and is decoded as a NOP instruction. The lower 12 bits of the second word contain data to be used by the instruction. If the first word of the instruction is executed, the data in the second word is accessed. If the

second word of the instruction is executed by itself (first word was skipped), it will execute as a NOP. This action is necessary when the two-word instruction is preceded by a conditional instruction that results in a skip operation. A program example that demonstrates this concept is shown in Example 5-3. Refer to Section 20.0 for further details of the instruction set.

EXAMPLE 5-3: TWO-WORD INSTRUCTIONS

CASE 1:		
Object Code	Source Code	
0110 0110 0000 0000	TSTFSZ	REG1 ; is RAM location 0?
1100 0001 0010 0011	MOVFF	REG1, REG2 ; No, skip this word
1111 0100 0101 0110		; Execute this word as a NOP
0010 0100 0000 0000	ADDWF	REG3 ; continue code
CASE 2:		
Object Code	Source Code	
0110 0110 0000 0000	TSTFSZ	REG1 ; is RAM location 0?
1100 0001 0010 0011	MOVFF	REG1, REG2 ; Yes, execute this word
1111 0100 0101 0110		; 2nd word of instruction
0010 0100 0000 0000	ADDWF	REG3 ; continue code

5.8 Lookup Tables

Lookup tables are implemented two ways:

- Computed GOTO
- Table Reads

5.8.1 COMPUTED GOTO

A computed GOTO is accomplished by adding an offset to the program counter. An example is shown in Example 5-4.

A lookup table can be formed with an ADDWF PCL instruction and a group of RETLW 0xnn instructions. WREG is loaded with an offset into the table before executing a call to that table. The first instruction of the called routine is the ADDWF PCL instruction. The next instruction executed will be one of the RETLW 0xnn instructions, that returns the value 0xnn to the calling function.

The offset value (in WREG) specifies the number of bytes that the program counter should advance, and should be multiples of 2 (LSB = 0).

In this method, only one data byte may be stored in each instruction location and room on the return address stack is required.

EXAMPLE 5-4: COMPUTED GOTO USING AN OFFSET VALUE

	MOVWF	OFFSET
	CALL	TABLE
ORG	0xnn00	
TABLE	ADDWF	PCL
	RETLW	0xnn
	RETLW	0xnn
	RETLW	0xnn
	.	
	.	
	.	

5.8.2 TABLE READS/TABLE WRITES

A better method of storing data in program memory allows two bytes of data to be stored in each instruction location.

Lookup table data may be stored two bytes per program word by using table reads and writes. The table pointer (TBLPTR) specifies the byte address and the table latch (TABLAT) contains the data that is read from, or written to program memory. Data is transferred to/from program memory, one byte at a time.

The Table Read/Table Write operation is discussed further in Section 6.1.

5.9 Data Memory Organization

The data memory is implemented as static RAM. Each register in the data memory has a 12-bit address, allowing up to 4096 bytes of data memory. Figure 5-6 shows the data memory organization for the PIC18F1220/1320 devices.

The data memory map is divided into as many as 16 banks that contain 256 bytes each. The lower 4 bits of the Bank Select Register (BSR<3:0>) select which bank will be accessed. The upper 4 bits for the BSR are not implemented.

The data memory contains Special Function Registers (SFR) and General Purpose Registers (GPR). The SFRs are used for control and status of the controller and peripheral functions, while GPRs are used for data storage and scratch pad operations in the user's application. The SFRs start at the last location of Bank 15 (FFFh) and extend towards F80h. Any remaining space beyond the SFRs in the Bank may be implemented as GPRs. GPRs start at the first location of Bank 0 and grow upwards. Any read of an unimplemented location will read as '0's.

The entire data memory may be accessed directly or indirectly. Direct addressing may require the use of the BSR register. Indirect addressing requires the use of a File Select Register (FSRn) and a corresponding Indirect File Operand (INDFn). Each FSR holds a 12-bit address value that can be used to access any location in the Data Memory map without banking. See Example 5.12 for indirect addressing details.

The instruction set and architecture allow operations across all banks. This may be accomplished by indirect addressing or by the use of the MOVFF instruction. The MOVFF instruction is a two-word/two-cycle instruction that moves a value from one register to another.

To ensure that commonly used registers (SFRs and select GPRs) can be accessed in a single cycle, regardless of the current BSR values, an Access Bank is implemented. A segment of Bank 0 and a segment of Bank 15 comprise the Access RAM. Section 5.10 provides a detailed description of the Access RAM.

5.9.1 GENERAL PURPOSE REGISTER FILE

Enhanced MCU devices may have banked memory in the GPR area. GPRs are not initialized by a Power-on Reset and are unchanged on all other RESETS.

Data RAM is available for use as GPR registers by all instructions. The second half of Bank 15 (F80h to FFFh) contains SFRs. All other banks of data memory contain GPRs, starting with Bank 0.

PIC18F1220/1320

FIGURE 5-6: DATA MEMORY MAP FOR PIC18F1220/1320 DEVICES

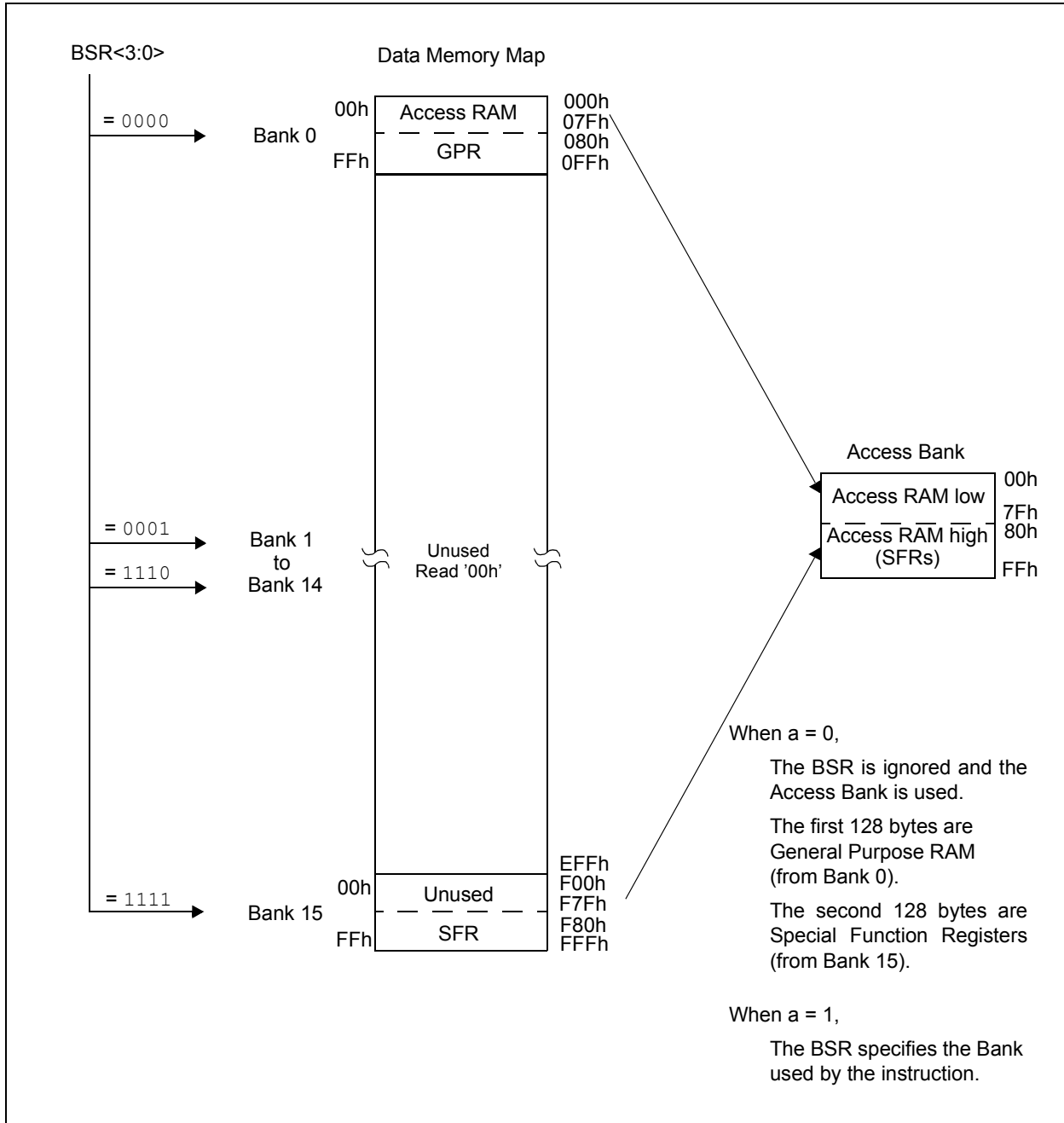

5.9.2 SPECIAL FUNCTION REGISTERS

The Special Function Registers (SFRs) are registers used by the CPU and Peripheral Modules for controlling the desired operation of the device. These registers are implemented as static RAM. A list of these registers is given in Table 5-1 and Table 5-2.

The SFRs can be classified into two sets: those associated with the “core” function and those related to the peripheral functions. Those registers related to the “core” are described in this section, while those related to the operation of the peripheral features are described in the section of that peripheral feature.

The SFRs are typically distributed among the peripherals whose functions they control.

The unused SFR locations will be unimplemented and read as ‘0’s.

TABLE 5-1: SPECIAL FUNCTION REGISTER MAP FOR PIC18F1220/1320 DEVICES

Address	Name	Address	Name	Address	Name	Address	Name
FFFh	TOSU	FDFh	INDF2 ⁽²⁾	FBFh	CCPR1H	F9Fh	IPR1
FFEh	TOSH	FDEh	POSTINC2 ⁽²⁾	FBEh	CCPR1L	F9Eh	PIR1
FFDh	TOSL	FDDh	POSTDEC2 ⁽²⁾	FBDh	CCP1CON	F9Dh	PIE1
FFCh	STKPTR	FDCh	PREINC2 ⁽²⁾	FBCCh	—	F9Ch	—
FFBh	PCLATU	FDBh	PLUSW2 ⁽²⁾	FBBh	—	F9Bh	OSCTUNE
FFAh	PCLATH	FDAh	FSR2H	FBAh	—	F9Ah	—
FF9h	PCL	FD9h	FSR2L	FB9h	—	F99h	—
FF8h	TBLPTRU	FD8h	STATUS	FB8h	—	F98h	—
FF7h	TBLPTRH	FD7h	TMR0H	FB7h	PWM1CON	F97h	—
FF6h	TBLPTRL	FD6h	TMR0L	FB6h	ECCPAS	F96h	—
FF5h	TABLAT	FD5h	T0CON	FB5h	—	F95h	—
FF4h	PRODH	FD4h	—	FB4h	—	F94h	—
FF3h	PRODL	FD3h	OSCCON	FB3h	TMR3H	F93h	TRISB
FF2h	INTCON	FD2h	LVDCON	FB2h	TMR3L	F92h	TRISA
FF1h	INTCON2	FD1h	WDTCON	FB1h	T3CON	F91h	—
FF0h	INTCON3	FD0h	RCON	FB0h	SPBRGH	F90h	—
FEFh	INDF0 ⁽²⁾	FCFh	TMR1H	FAFh	SPBRG	F8Fh	—
FEEh	POSTINC0 ⁽²⁾	FCEh	TMR1L	FAEh	RCREG	F8Eh	—
FEDh	POSTDEC0 ⁽²⁾	FCDh	T1CON	FADh	TXREG	F8Dh	—
FECh	PREINC0 ⁽²⁾	FCCh	TMR2	FACH	TXSTA	F8Ch	—
FEBh	PLUSW0 ⁽²⁾	FCBh	PR2	FABh	RCSTA	F8Bh	—
FEAh	FSR0H	FCAh	T2CON	FAAh	BAUDCTL	F8Ah	LATB
FE9h	FSR0L	FC9h	—	FA9h	EEADR	F89h	LATA
FE8h	WREG	FC8h	—	FA8h	EEDATA	F88h	—
FE7h	INDF1 ⁽²⁾	FC7h	—	FA7h	EECON2	F87h	—
FE6h	POSTINC1 ⁽²⁾	FC6h	—	FA6h	EECON1	F86h	—
FE5h	POSTDEC1 ⁽²⁾	FC5h	—	FA5h	—	F85h	—
FE4h	PREINC1 ⁽²⁾	FC4h	ADRESH	FA4h	—	F84h	—
FE3h	PLUSW1 ⁽²⁾	FC3h	ADRESL	FA3h	—	F83h	—
FE2h	FSR1H	FC2h	ADCON0	FA2h	IPR2	F82h	—
FE1h	FSR1L	FC1h	ADCON1	FA1h	PIR2	F81h	PORTB
FE0h	BSR	FC0h	ADCON2	FA0h	PIE2	F80h	PORTA

Note 1: Unimplemented registers are read as ‘0’.

Note 2: This is not a physical register.

PIC18F1220/1320

TABLE 5-2: REGISTER FILE SUMMARY (PIC18F1220/1320)

File Name	Bit 7	Bit 6	Bit 5	Bit 4	Bit 3	Bit 2	Bit 1	Bit 0	Value on POR, BOR	Details on page:
TOSU	—	—	—	Top-of-Stack Upper Byte (TOS<20:16>)					---0 0000	36, 44
TOSH	Top-of-Stack High Byte (TOS<15:8>)								0000 0000	36, 44
TOSL	Top-of-Stack Low Byte (TOS<7:0>)								0000 0000	36, 44
STKPTR	STKFUL	STKUNF	—	Return Stack Pointer					00-0 0000	36, 45
PCLATU	—	—	bit21 ⁽³⁾	Holding Register for PC<20:16>					---0 0000	36, 46
PCLATH	Holding Register for PC<15:8>								0000 0000	36, 46
PCL	PC Low Byte (PC<7:0>)								0000 0000	36, 46
TBLPTRU	—	—	bit21	Program Memory Table Pointer Upper Byte (TBLPTR<20:16>)					--00 0000	36, 62
TBLPTRH	Program Memory Table Pointer High Byte (TBLPTR<15:8>)								0000 0000	36, 62
TBLPTRL	Program Memory Table Pointer Low Byte (TBLPTR<7:0>)								0000 0000	36, 62
TABLAT	Program Memory Table Latch								0000 0000	36, 62
PRODH	Product Register High Byte								xxxx xxxx	36, 73
PRODL	Product Register Low Byte								xxxx xxxx	36, 73
INTCON	GIE/GIEH	PEIE/GIEL	TMR0IE	INT0E	RBIE	TMR0IF	INT0F	RBIF	0000 000x	36, 77
INTCON2	RBPV	INTEDG0	INTEDG1	INTEDG2	—	TMR0IP	—	RBIP	1111 -1-1	36, 78
INTCON3	INT2P	INT1P	—	INT2E	INT1E	—	INT2F	INT1F	11-0 0-00	36, 79
INDF0	Uses contents of FSR0 to address data memory - value of FSR0 not changed (not a physical register)								n/a	36, 55
POSTINC0	Uses contents of FSR0 to address data memory - value of FSR0 post-incremented (not a physical register)								n/a	36, 55
POSTDEC0	Uses contents of FSR0 to address data memory - value of FSR0 post-decremented (not a physical register)								n/a	36, 55
PREINC0	Uses contents of FSR0 to address data memory - value of FSR0 pre-incremented (not a physical register)								n/a	36, 55
PLUSW0	Uses contents of FSR0 to address data memory - value of FSR0 offset by W (not a physical register)								n/a	36, 55
FSR0H	—	—	—	—	Indirect Data Memory Address Pointer 0 High				---- 0000	36, 55
FSR0L	Indirect Data Memory Address Pointer 0 Low Byte								xxxx xxxx	36, 55
WREG	Working Register								xxxx xxxx	36
INDF1	Uses contents of FSR1 to address data memory - value of FSR1 not changed (not a physical register)								n/a	36, 55
POSTINC1	Uses contents of FSR1 to address data memory - value of FSR1 post-incremented (not a physical register)								n/a	36, 55
POSTDEC1	Uses contents of FSR1 to address data memory - value of FSR1 post-decremented (not a physical register)								n/a	36, 55
PREINC1	Uses contents of FSR1 to address data memory - value of FSR1 pre-incremented (not a physical register)								n/a	36, 55
PLUSW1	Uses contents of FSR1 to address data memory - value of FSR1 offset by W (not a physical register)								n/a	36, 55
FSR1H	—	—	—	—	Indirect Data Memory Address Pointer 1 High				---- 0000	37, 55
FSR1L	Indirect Data Memory Address Pointer 1 Low Byte								xxxx xxxx	37, 55
BSR	—	—	—	—	Bank Select Register				---- 0000	37, 54
INDF2	Uses contents of FSR2 to address data memory - value of FSR2 not changed (not a physical register)								n/a	37, 55
POSTINC2	Uses contents of FSR2 to address data memory - value of FSR2 post-incremented (not a physical register)								n/a	37, 55
POSTDEC2	Uses contents of FSR2 to address data memory - value of FSR2 post-decremented (not a physical register)								n/a	37, 55
PREINC2	Uses contents of FSR2 to address data memory - value of FSR2 pre-incremented (not a physical register)								n/a	37, 55
PLUSW2	Uses contents of FSR2 to address data memory - value of FSR2 offset by W (not a physical register)								n/a	37, 55
FSR2H	—	—	—	—	Indirect Data Memory Address Pointer 2 High				---- 0000	37, 55
FSR2L	Indirect Data Memory Address Pointer 2 Low Byte								xxxx xxxx	37, 55
STATUS	—	—	—	N	OV	Z	DC	C	---x xxxx	37, 57
TMR0H	Timer0 Register High Byte								0000 0000	37, 103
TMR0L	Timer0 Register Low Byte								xxxx xxxx	37, 103
T0CON	TMR0ON	T08BIT	T0CS	T0SE	PSA	T0PS2	T0PS1	T0PS0	1111 1111	37, 101
OSCCON	IDLEN	IRCF2	IRCF1	IRCF0	OSTS	FLTS	SCS1	SCS0	0000 q000	37, 17
LVDCON	—	—	IVRST	LV DEN	LV DL3	LV DL2	LV DL1	LV DL0	--00 0101	37, 167
WDTCON	—	—	—	—	—	—	—	SWDTEN	--- ---0	37, 180
RCON	IPEN	—	—	RI	TO	PD	POR	BOR	0--1 11q0	35, 58, 86

Legend: x = unknown, u = unchanged, - = unimplemented, q = value depends on condition

Note 1: RA6 and associated bits are configured as port pins in RCIO, ECIO, and INTIO2 (with port function on RA6) Oscillator mode only, and read '0' in all other Oscillator modes.

2: RA7 and associated bits are configured as port pins in INTIO2 Oscillator mode only, and read '0' in all other modes.

3: Bit 21 of the PC is only available in Test mode and Serial Programming modes.

4: The RA5 port bit is only available when MCLRE fuse (CONFIG3H<7>) is programmed to '0'. Otherwise, RA5 reads '0'. This bit is read only.

PIC18F1220/1320

TABLE 5-2: REGISTER FILE SUMMARY (PIC18F1220/1320) (CONTINUED)

File Name	Bit 7	Bit 6	Bit 5	Bit 4	Bit 3	Bit 2	Bit 1	Bit 0	Value on POR, BOR	Details on page:
TMR1H	Timer1 Register High Byte								xxxx xxxx	37, 109
TMR1L	Timer1 Register Low Byte								xxxx xxxx	37, 109
T1CON	RD16	T1RUN	T1CKPS1	T1CKPS0	T1OSCEN	T1SYNC	TMR1CS	TMR1ON	0000 0000	37, 105
TMR2	Timer2 Register								0000 0000	37, 111
PR2	Timer2 Period Register								1111 1111	37, 111
T2CON	—	TOUTPS3	TOUTPS2	TOUTPS1	TOUTPS0	TMR2ON	T2CKPS1	T2CKPS0	-000 0000	37, 111
ADRESH	A/D Result Register High Byte								xxxx xxxx	38, 164
ADRESL	A/D Result Register Low Byte								xxxx xxxx	38, 164
ADCON0	VCFG1	VCFG0	—	CHS2	CHS1	CHS0	GO/DONE	ADON	00-0 0000	38, 155
ADCON1	—	PCFG6	PCFG5	PCFG4	PCFG3	PCFG2	PCFG1	PCFG0	--00 0000	38, 156
ADCON2	ADFM	—	ACQT2	ACQT1	ACQT0	ADCS2	ADCS1	ADCS0	0-00 0000	38, 157
CCPR1H	Capture/Compare/PWM Register1 High Byte								xxxx xxxx	38, 118
CCPR1L	Capture/Compare/PWM Register1 Low Byte								xxxx xxxx	38, 118
CCP1CON	P1M1	P1M0	DC1B1	DC1B0	CCP1M3	CCP1M2	CCP1M1	CCP1M0	0000 0000	38, 117
PWM1CON	PRSEN	PDC6	PDC5	PDC4	PDC3	PDC2	PDC1	PDC0	0000 0000	38, 128
ECCPAS	ECCPASE	ECCPAS2	ECCPAS1	ECCPAS0	PSSAC1	PSSAC0	PSSBD1	PSSBD0	0000 0000	38, 129
TMR3H	Timer3 Register High Byte								xxxx xxxx	38, 116
TMR3L	Timer3 Register Low Byte								xxxx xxxx	38, 116
T3CON	RD16	T3CCP2	T3CKPS1	T3CKPS0	T3CCP1	T3SYNC	TMR3CS	TMR3ON	0000 0000	38, 113
SPBRGH	USART Baud Rate Generator High Byte								0000 0000	38
SPBRG	USART Baud Rate Generator Low Byte								0000 0000	38, 137
RCREG	USART Receive Register								0000 0000	38, 145, 144
TXREG	USART Transmit Register								0000 0000	38, 142, 144
TXSTA	CSRC	TX9	TXEN	SYNC	SEnDB	BRGH	TRMT	TX9D	0000 0010	38, 134
RCSTA	SPEN	RX9	SREN	CREN	ADDEN	FERR	OERR	RX9D	0000 000x	38, 135
BAUDCTL	—	RCIDL	—	SCKP	BRG16	—	W4E	ABDEN	-1-1 0-00	38
EEADR	EEPROM Address Register								0000 0000	38, 69
EEDATA	EEPROM Data Register								0000 0000	38, 72
EECON2	EEPROM Control Register2 (not a physical register)								0000 0000	38, 60, 69
EECON1	EEPGD	CFGS	—	FREE	WRERR	WREN	WR	RD	xx-0 x000	38, 61, 70
IPR2	OSCFIP	—	—	EEIP	—	LVDIP	TMR3IP	—	1--1 -11-	39, 85
PIR2	OSCFIF	—	—	EEIF	—	LVDIF	TMR3IF	—	0--0 -00-	39, 81
PIE2	OSCFIE	—	—	EEIE	—	LVDIE	TMR3IE	—	0--0 -00-	39, 83
IPR1	—	ADIP	RCIP	TXIP	—	CCP1IP	TMR2IP	TMR1IP	-111 -111	39, 84
PIR1	—	ADIF	RCIF	TXIF	—	CCP1IF	TMR2IF	TMR1IF	-000 -000	39, 80
PIE1	—	ADIE	RCIE	TXIE	—	CCP1IE	TMR2IE	TMR1IE	-000 -000	39, 82
OSCTUNE	—	—	TUN5	TUN4	TUN3	TUN2	TUN1	TUN0	--00 0000	39, 15
TRISB	Data Direction Control Register for PORTB								1111 1111	39, 100
TRISA	TRISA7 ⁽²⁾	TRISA6 ⁽¹⁾	—	Data Direction Control Register for PORTA					11-1 1111	39, 91
LATB	Read/Write PORTB Data Latch								xxxx xxxx	39, 100
LATA	LATA<7> ⁽²⁾	LATA<6> ⁽¹⁾	—	Read/Write PORTA Data Latch					xx-x xxxx	39, 91
PORTB	Read PORTB pins, Write PORTB Data Latch								xxxx xxxx	39, 100
PORTA	RA7 ⁽²⁾	RA6 ⁽¹⁾	RA5 ⁽⁴⁾	Read PORTA pins, Write PORTA Data Latch					xx0x 0000	39, 91

Legend: x = unknown, u = unchanged, - = unimplemented, q = value depends on condition

Note 1: RA6 and associated bits are configured as port pins in RCIO, ECIO, and INTIO2 (with port function on RA6) Oscillator mode only, and read '0' in all other Oscillator modes.

2: RA7 and associated bits are configured as port pins in INTIO2 Oscillator mode only, and read '0' in all other modes.

3: Bit 21 of the PC is only available in Test mode and Serial Programming modes.

4: The RA5 port bit is only available when MCLRE fuse (CONFIG3H<7>) is programmed to '0'. Otherwise, RA5 reads '0'. This bit is read only.

PIC18F1220/1320

5.10 Access Bank

The Access Bank is an architectural enhancement which is very useful for C compiler code optimization. The techniques used by the C compiler may also be useful for programs written in assembly.

This data memory region can be used for:

- Intermediate computational values
- Local variables of subroutines
- Faster context saving/switching of variables
- Common variables
- Faster evaluation/control of SFRs (no banking)

The Access Bank is comprised of the last 128 bytes in Bank 15 (SFRs) and the first 128 bytes in Bank 0. These two sections will be referred to as Access RAM High and Access RAM Low, respectively. Figure 5-6 indicates the Access RAM areas.

A bit in the instruction word specifies if the operation is to occur in the bank specified by the BSR register or in the Access Bank. This bit is denoted as the 'a' bit (for access bit).

When forced in the Access Bank (a = 0), the last address in Access RAM Low is followed by the first address in Access RAM High. Access RAM High maps the Special Function registers, so these registers can be accessed without any software overhead. This is useful for testing status flags and modifying control bits.

5.11 Bank Select Register (BSR)

The need for a large general purpose memory space dictates a RAM banking scheme. The data memory is partitioned into as many as sixteen banks. When using direct addressing, the BSR should be configured for the desired bank.

BSR<3:0> holds the upper 4 bits of the 12-bit RAM address. The BSR<7:4> bits will always read '0's, and writes will have no effect (see Figure 5-7).

A `MOVLB` instruction has been provided in the instruction set to assist in selecting banks.

If the currently selected bank is not implemented, any read will return all '0's and all writes are ignored. The STATUS register bits will be set/cleared as appropriate for the instruction performed.

Each Bank extends up to FFh (256 bytes). All data memory is implemented as static RAM.

A `MOVFF` instruction ignores the BSR, since the 12-bit addresses are embedded into the instruction word.

Section 5.12 provides a description of indirect addressing, which allows linear addressing of the entire RAM space.

FIGURE 5-7: DIRECT ADDRESSING

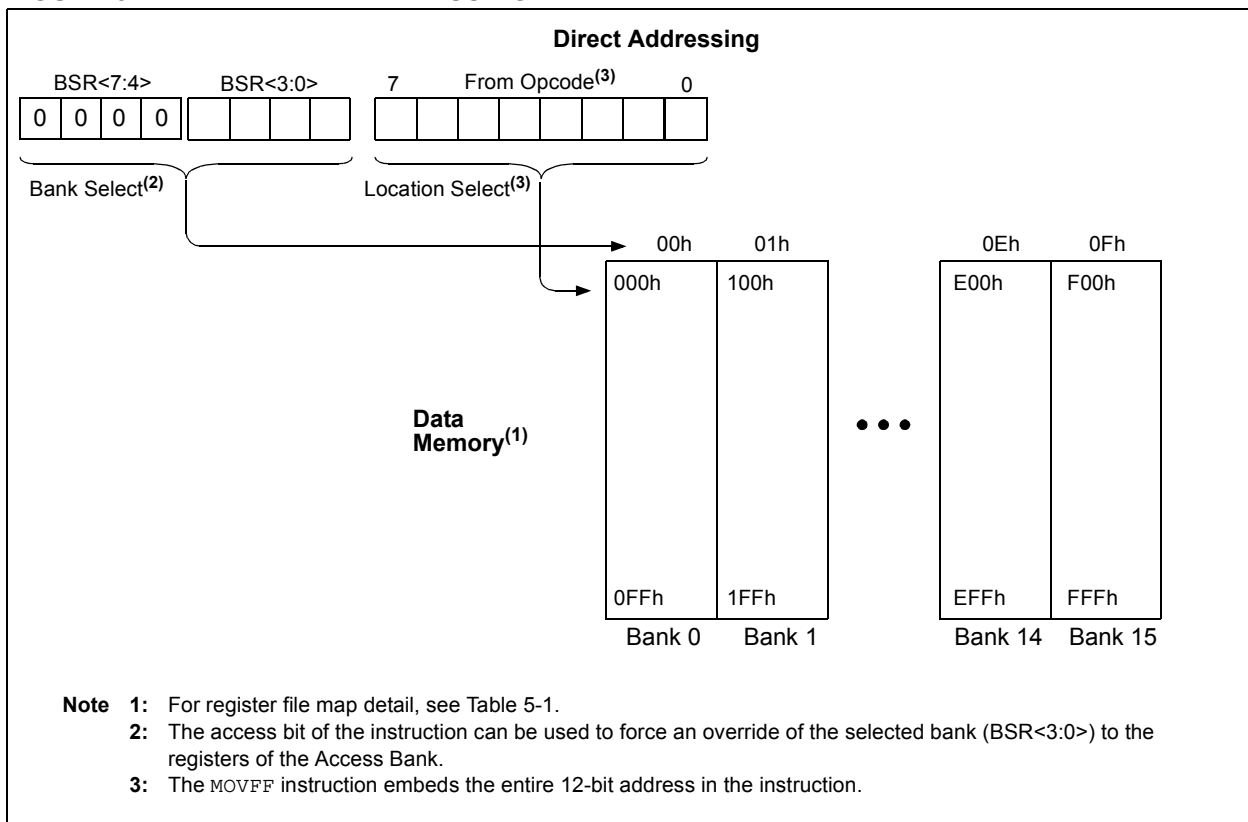

5.12 Indirect Addressing, INDF and FSR Registers

Indirect addressing is a mode of addressing data memory, where the data memory address in the instruction is not fixed. An FSR register is used as a pointer to the data memory location that is to be read or written. Since this pointer is in RAM, the contents can be modified by the program. This can be useful for data tables in the data memory and for software stacks. Figure 5-8 shows how the fetched instruction is modified prior to being executed.

Indirect addressing is possible by using one of the INDF registers. Any instruction, using the INDF register, actually accesses the register pointed to by the File Select Register, FSR. Reading the INDF register itself, indirectly (FSR = 0), will read 00h. Writing to the INDF register indirectly, results in a no operation. The FSR register contains a 12-bit address, which is shown in Figure 5-9.

The INDFn register is not a physical register. Addressing INDFn actually addresses the register whose address is contained in the FSRn register (FSRn is a pointer). This is indirect addressing.

Example 5-5 shows a simple use of indirect addressing to clear the RAM in Bank1 (locations 100h-1FFh) in a minimum number of instructions.

EXAMPLE 5-5: HOW TO CLEAR RAM (BANK1) USING INDIRECT ADDRESSING

```

LFSR FSR0 ,0x100 ;
NEXT CLR FSR0 POSTINC0 ; Clear INDF
; register then
; inc pointer
BTFSS FSR0H, 1 ; All done with
; Bank1?
GOTO NEXT ; NO, clear next
CONTINUE ; YES, continue
    
```

There are three indirect addressing registers. To address the entire data memory space (4096 bytes), these registers are 12-bit wide. To store the 12 bits of addressing information, two 8-bit registers are required:

1. FSR0: composed of FSR0H:FSR0L
2. FSR1: composed of FSR1H:FSR1L
3. FSR2: composed of FSR2H:FSR2L

In addition, there are registers INDF0, INDF1 and INDF2, which are not physically implemented. Reading or writing to these registers activates indirect addressing, with the value in the corresponding FSR register being the address of the data. If an instruction writes a value to INDF0, the value will be written to the address pointed to by FSR0H:FSR0L. A read from INDF1 reads the data from the address pointed to by FSR1H:FSR1L. INDFn can be used in code anywhere an operand can be used.

If INDF0, INDF1 or INDF2 are read indirectly via an FSR, all '0's are read (zero bit is set). Similarly, if INDF0, INDF1 or INDF2 are written to indirectly, the operation will be equivalent to a NOP instruction and the STATUS bits are not affected.

5.12.1 INDIRECT ADDRESSING OPERATION

Each FSR register has an INDF register associated with it, plus four additional register addresses. Performing an operation using one of these five registers determines how the FSR will be modified during indirect addressing.

When data access is performed using one of the five INDFn locations, the address selected will configure the FSRn register to:

- Do nothing to FSRn after an indirect access (no change) - INDFn
- Auto-decrement FSRn after an indirect access (post-decrement) - POSTDECn
- Auto-increment FSRn after an indirect access (post-increment) - POSTINCn
- Auto-increment FSRn before an indirect access (pre-increment) - PREINCn
- Use the value in the WREG register as an offset to FSRn. Do not modify the value of the WREG or the FSRn register after an indirect access (no change) - PLUSWn

When using the auto-increment or auto-decrement features, the effect on the FSR is not reflected in the STATUS register. For example, if the indirect address causes the FSR to equal '0', the Z bit will not be set.

Auto-incrementing or auto-decrementing an FSR affects all 12 bits. That is, when FSRnL overflows from an increment, FSRnH will be incremented automatically.

Adding these features allows the FSRn to be used as a stack pointer, in addition to its uses for table operations in data memory.

Each FSR has an address associated with it that performs an indexed indirect access. When a data access to this INDFn location (PLUSWn) occurs, the FSRn is configured to add the signed value in the WREG register and the value in FSR to form the address before an indirect access. The FSR value is not changed. The WREG offset range is -128 to +127.

If an FSR register contains a value that points to one of the INDFn, an indirect read will read 00h (zero bit is set), while an indirect write will be equivalent to a NOP (STATUS bits are not affected).

If an indirect addressing write is performed when the target address is an FSRnH or FSRnL register, the data is written to the FSR register, but no pre- or post-increment/decrement is performed.

PIC18F1220/1320

FIGURE 5-8: INDIRECT ADDRESSING OPERATION

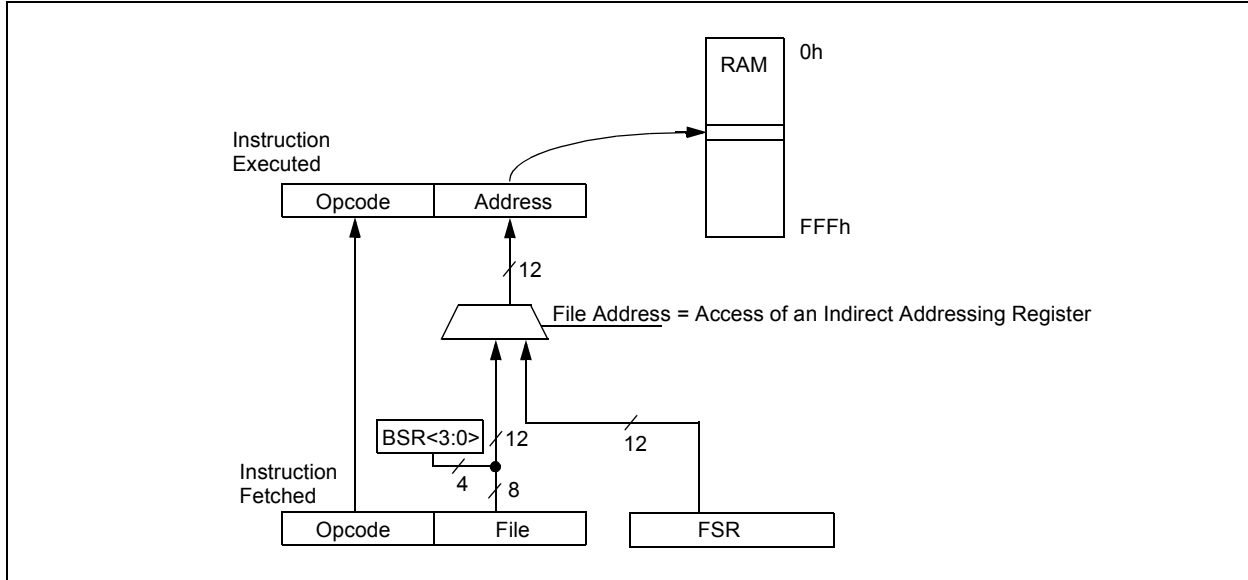
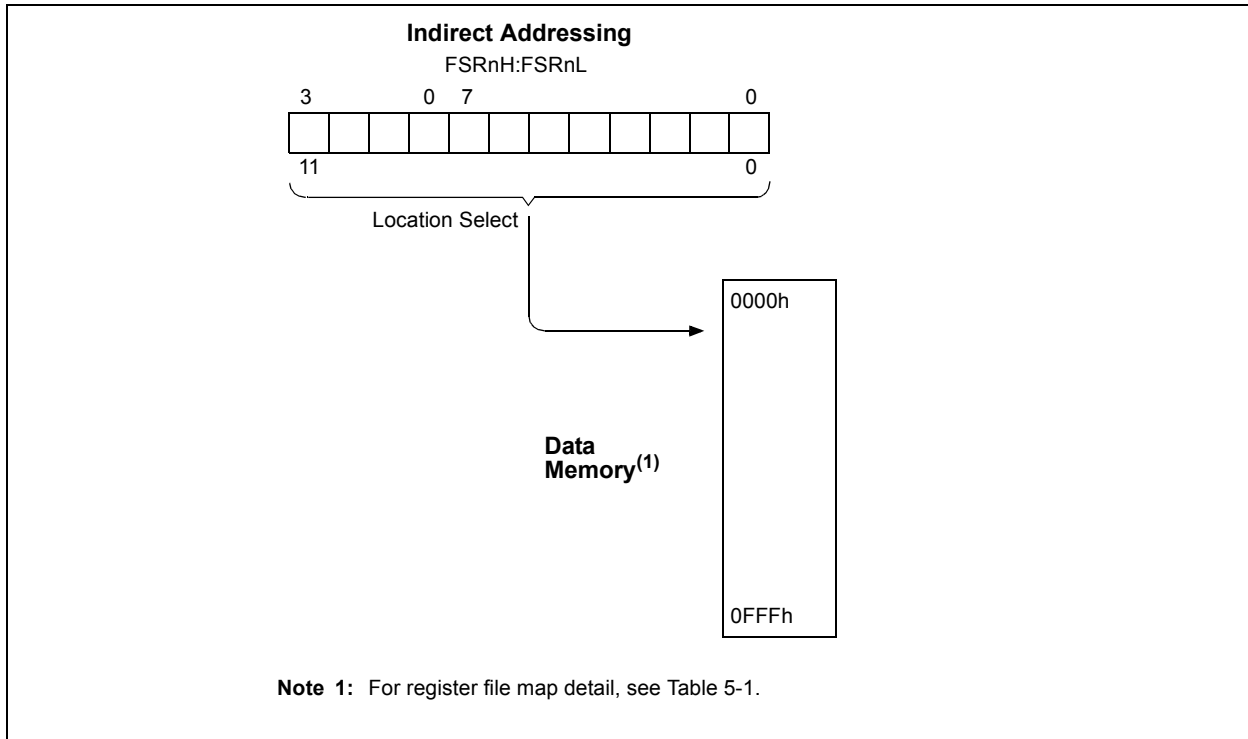

FIGURE 5-9: INDIRECT ADDRESSING



5.13 STATUS Register

The STATUS register, shown in Register 5-2, contains the arithmetic status of the ALU. The STATUS register can be the operand for any instruction, as with any other register. If the STATUS register is the destination for an instruction that affects the Z, DC, C, OV, or N bits, then the write to these five bits is disabled. These bits are set or cleared according to the device logic. Therefore, the result of an instruction with the STATUS register as destination may be different than intended.

For example, `CLRF STATUS` will clear the upper three bits and set the Z bit. This leaves the STATUS register as `000u u1uu` (where u = unchanged).

It is recommended, therefore, that only `BCF`, `BSF`, `SWAPF`, `MOVFF` and `MOVWF` instructions are used to alter the STATUS register, because these instructions do not affect the Z, C, DC, OV, or N bits in the STATUS register. For other instructions not affecting any status bits, see Table 20-2.

Note: The C and DC bits operate as a borrow and digit borrow bit respectively, in subtraction.

REGISTER 5-2: STATUS REGISTER

	U-0	U-0	U-0	R/W-x	R/W-x	R/W-x	R/W-x	R/W-x
	—	—	—	N	OV	Z	DC	C
bit 7								bit 0

bit 7-5 **Unimplemented:** Read as '0'

bit 4 **N:** Negative bit
 This bit is used for signed arithmetic (2's complement). It indicates whether the result was negative (ALU MSB = 1).
 1 = Result was negative
 0 = Result was positive

bit 3 **OV:** Overflow bit
 This bit is used for signed arithmetic (2's complement). It indicates an overflow of the 7-bit magnitude, which causes the sign bit (bit 7) to change state.
 1 = Overflow occurred for signed arithmetic (in this arithmetic operation)
 0 = No overflow occurred

bit 2 **Z:** Zero bit
 1 = The result of an arithmetic or logic operation is zero
 0 = The result of an arithmetic or logic operation is not zero

bit 1 **DC:** Digit carry/borrow bit
 For `ADDWF`, `ADDLW`, `SUBLW`, and `SUBWF` instructions
 1 = A carry-out from the 4th low order bit of the result occurred
 0 = No carry-out from the 4th low order bit of the result

Note: For borrow, the polarity is reversed. A subtraction is executed by adding the two's complement of the second operand. For rotate (`RRF`, `RLF`) instructions, this bit is loaded with either the bit 4 or bit 3 of the source register.

bit 0 **C:** Carry/borrow bit
 For `ADDWF`, `ADDLW`, `SUBLW`, and `SUBWF` instructions
 1 = A carry-out from the Most Significant bit of the result occurred
 0 = No carry-out from the Most Significant bit of the result occurred

Note: For borrow, the polarity is reversed. A subtraction is executed by adding the two's complement of the second operand. For rotate (`RRF`, `RLF`) instructions, this bit is loaded with either the high or low order bit of the source register.

Legend:

R = Readable bit	W = Writable bit	U = Unimplemented bit, read as '0'
- n = Value at POR	'1' = Bit is set	'0' = Bit is cleared x = Bit is unknown

PIC18F1220/1320

5.14 RCON Register

The Reset Control (RCON) register contains flag bits that allow differentiation between the sources of a device RESET. These flags include the \overline{TO} , \overline{PD} , \overline{POR} , \overline{BOR} and \overline{RI} bits. This register is readable and writable.

Note 1: If the BOREN configuration bit is set (Brown-out Reset enabled), the \overline{BOR} bit is '1' on a Power-on Reset. After a Brown-out Reset has occurred, the \overline{BOR} bit will be cleared, and must be set by firmware to indicate the occurrence of the next Brown-out Reset.

2: It is recommended that the \overline{POR} bit be set after a Power-on Reset has been detected, so that subsequent Power-on Resets may be detected.

REGISTER 5-3: RCON REGISTER

R/W-0	U-0	U-0	R/W-1	R-1	R-1	R/W-0	R/W-0	
IPEN	—	—	\overline{RI}	\overline{TO}	\overline{PD}	\overline{POR}	\overline{BOR}	
bit 7								bit 0

- bit 7 **IPEN:** Interrupt Priority Enable bit
 1 = Enable priority levels on interrupts
 0 = Disable priority levels on interrupts (PIC16CXXX Compatibility mode)
- bit 6-5 **Unimplemented:** Read as '0'
- bit 4 **\overline{RI} :** RESET Instruction Flag bit
 1 = The RESET instruction was not executed (set by firmware only)
 0 = The RESET instruction was executed causing a device RESET (must be set in software after a Brown-out Reset occurs)
- bit 3 **\overline{TO} :** Watchdog Time-out Flag bit
 1 = Set by power-up, CLRWD \overline{T} instruction, or SLEEP instruction
 0 = A WDT time-out occurred
- bit 2 **\overline{PD} :** Power-down Detection Flag bit
 1 = Set by power-up or by the CLRWD \overline{T} instruction
 0 = Cleared by execution of the SLEEP instruction
- bit 1 **\overline{POR} :** Power-on Reset Status bit
 1 = A Power-on Reset has not occurred (set by firmware only)
 0 = A Power-on Reset occurred (must be set in software after a Power-on Reset occurs)
- bit 0 **\overline{BOR} :** Brown-out Reset Status bit
 1 = A Brown-out Reset has not occurred (set by firmware only)
 0 = A Brown-out Reset occurred (must be set in software after a Brown-out Reset occurs)

Legend:

R = Readable bit W = Writable bit U = Unimplemented bit, read as '0'
 - n = Value at POR '1' = Bit is set '0' = Bit is cleared x = Bit is unknown

6.0 FLASH PROGRAM MEMORY

The FLASH Program Memory is readable, writable, and erasable during normal operation over the entire VDD range.

A read from program memory is executed on one byte at a time. A write to program memory is executed on blocks of 8 bytes at a time. Program memory is erased in blocks of 64 bytes at a time. A bulk erase operation may not be issued from user code.

While writing or erasing program memory, instruction fetches cease until the operation is complete. The program memory cannot be accessed during the write or erase, therefore, code cannot execute. An internal programming timer terminates program memory writes and erases.

A value written to program memory does not need to be a valid instruction. Executing a program memory location that forms an invalid instruction results in a NOP.

6.1 Table Reads and Table Writes

In order to read and write program memory, there are two operations that allow the processor to move bytes between the program memory space and the data RAM:

- Table Read (TBLRD)
- Table Write (TBLWT)

The program memory space is 16-bits wide, while the data RAM space is 8-bits wide. Table Reads and Table Writes move data between these two memory spaces through an 8-bit register (TABLAT).

Table Read operations retrieve data from program memory and place it into TABLAT in the data RAM space. Figure 6-1 shows the operation of a Table Read with program memory and data RAM.

Table Write operations store data from TABLAT in the data memory space into holding registers in program memory. The procedure to write the contents of the holding registers into program memory is detailed in Section 6.5, "Writing to FLASH Program Memory". Figure 6-2 shows the operation of a Table Write with program memory and data RAM.

Table operations work with byte entities. A table block containing data, rather than program instructions, is not required to be word aligned. Therefore, a table block can start and end at any byte address. If a Table Write is being used to write executable code into program memory, program instructions will need to be word aligned (TBLPTRL<0> = 0).

The EEPROM on-chip timer controls the write and erase times. The write and erase voltages are generated by an on-chip charge pump rated to operate over the voltage range of the device for byte or word operations.

FIGURE 6-1: TABLE READ OPERATION

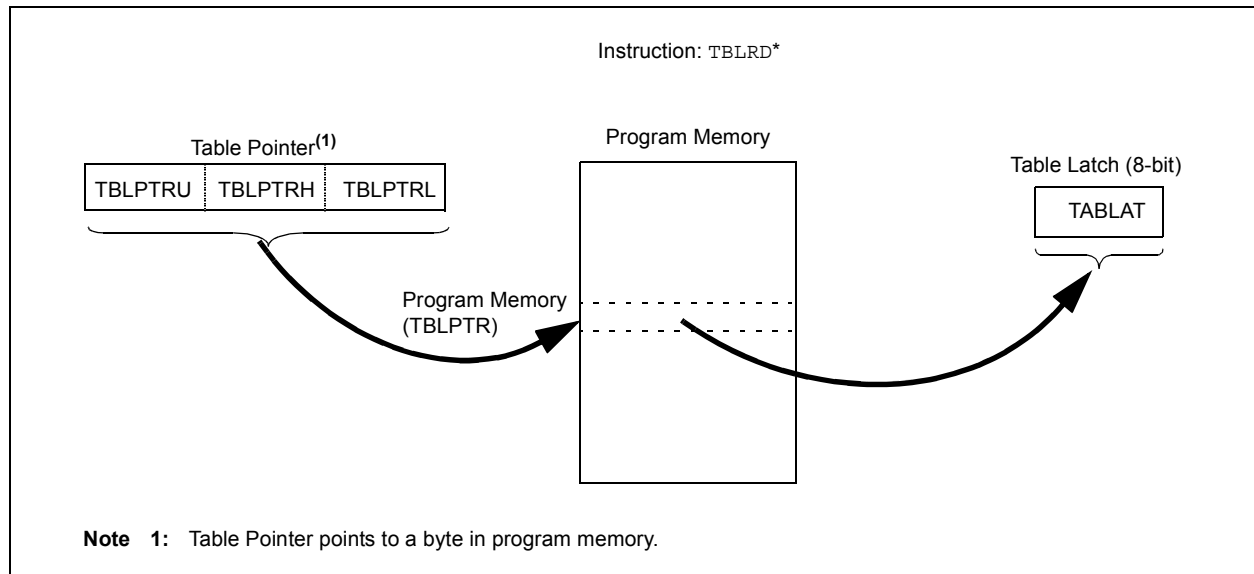

PIC18F1220/1320

FIGURE 6-2: TABLE WRITE OPERATION

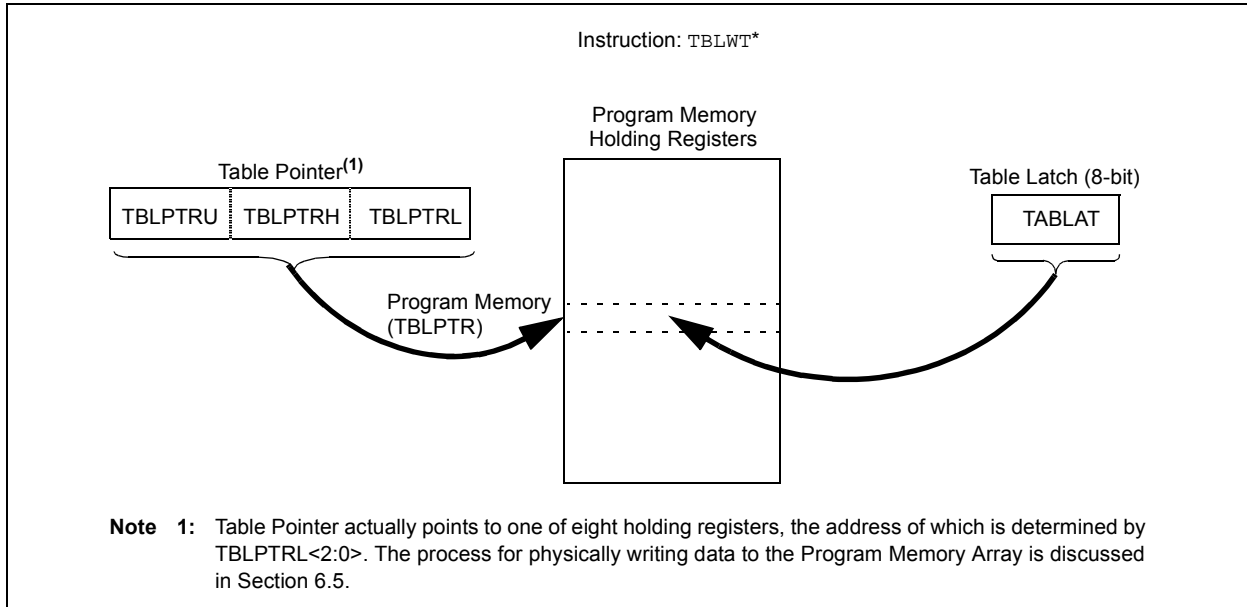

6.2 Control Registers

Several control registers are used in conjunction with the TBLRD and TBLWT instructions. These include the:

- EECON1 register
- EECON2 register
- TABLAT register
- TBLPTR registers

6.2.1 EECON1 AND EECON2 REGISTERS

EECON1 is the control register for memory accesses.

EECON2 is not a physical register. Reading EECON2 will read all '0's. The EECON2 register is used exclusively in the memory write and erase sequences.

Control bit EEPGD determines if the access will be to program or data EEPROM memory. When clear, operations will access the data EEPROM memory. When set, program memory is accessed.

Control bit CFGS determines if the access will be to the configuration registers, or to program memory/data EEPROM memory. When set, subsequent operations access configuration registers. When CFGS is clear, the EEPGD bit selects either program FLASH or Data EEPROM memory.

The FREE bit controls program memory erase operations. When the FREE bit is set, the erase operation is initiated on the next WR command. When FREE is clear, only writes are enabled.

The WREN bit enables and disables erase and write operations. When set, erase and write operations are allowed. When clear, erase and write operations are disabled – the WR bit cannot be set while the WREN bit is clear. This process helps to prevent accidental writes to memory due to errant (unexpected) code execution.

Firmware should keep the WREN bit clear at all times, except when starting erase or write operations. Once firmware has set the WR bit, the WREN bit may be cleared. Clearing the WREN bit will not affect the operation in progress.

The WRERR bit is set when a write operation is interrupted by a RESET. In these situations, the user can check the WRERR bit and rewrite the location. It will be necessary to reload the data and address registers (EEDATA and EEADR) as these registers have cleared as a result of the RESET.

Control bits RD and WR start read and erase/write operations, respectively. These bits are set by firmware, and cleared by hardware at the completion of the operation.

The RD bit cannot be set when accessing program memory (EEPGD = 1). Program memory is read using Table Read instructions. See Section 6.3 regarding Table Reads.

Note: Interrupt flag bit EEIF, in the PIR2 register, is set when the write is complete. It must be cleared in software.

REGISTER 6-1: EECON1 REGISTER

R/W-x	R/W-x	U-0	R/W-0	R/W-x	R/W-0	R/S-0	R/S-0
EEPGD	CFGS	—	FREE	WRERR	WREN	WR	RD
bit 7						bit 0	

- bit 7 **EEPGD:** FLASH Program or Data EEPROM Memory Select bit
 1 = Access program FLASH memory
 0 = Access data EEPROM memory
- bit 6 **CFGS:** FLASH Program/Data EE or Configuration Select bit
 1 = Access configuration registers
 0 = Access program FLASH or data EEPROM memory
- bit 5 **Unimplemented:** Read as '0'
- bit 4 **FREE:** FLASH Row Erase Enable bit
 1 = Erase the program memory row addressed by TBLPTR on the next WR command
 (cleared by completion of erase operation — TBLPTR<5:0> are ignored)
 0 = Perform write only
- bit 3 **WRERR:** EEPROM Error Flag bit
 1 = A write operation was prematurely terminated
 (any RESET during self-timed programming)
 0 = The write operation completed normally
Note: When a WRERR occurs, the EEGPD and CFGS bits are not cleared. This allows tracing of the error condition.
- bit 2 **WREN:** Write Enable bit
 1 = Allows erase or write cycles
 0 = Inhibits erase or write cycles
- bit 1 **WR:** Write Control bit
 1 = Initiates a data EEPROM erase/write cycle or a program memory erase cycle or write cycle.
 (The operation is self-timed and the bit is cleared by hardware once write is complete. The WR bit can only be set (not cleared) in software.)
 0 = Write cycle completed
- bit 0 **RD:** Read Control bit
 1 = Initiates a memory read
 (Read takes one cycle. RD is cleared in hardware. The RD bit can only be set (not cleared) in software. RD bit cannot be set when EEGPD = 1.)
 0 = Read completed

Legend:

R = Readable bit	S = Settable only	U = Unimplemented bit, read as '0'
W = Writable bit	- n = Value at POR	'1' = Bit is set '0' = Bit is cleared
x = Bit is unknown		

PIC18F1220/1320

6.2.2 TABLAT - TABLE LATCH REGISTER

The Table Latch (TABLAT) is an 8-bit register mapped into the SFR space. The Table Latch is used to hold 8-bit data during data transfers between program memory and data RAM.

6.2.3 TBLPTR - TABLE POINTER REGISTER

The Table Pointer (TBLPTR) addresses a byte within the program memory. The TBLPTR is comprised of three SFR registers: Table Pointer Upper Byte, Table Pointer High Byte and Table Pointer Low Byte (TBLPTRU:TBLPTRH:TBLPTRL). These three registers join to form a 22-bit wide pointer. The low order 21 bits allow the device to address up to 2 Mbytes of program memory space. Setting the 22nd bit allows access to the Device ID, the User ID and the Configuration bits.

The Table Pointer, TBLPTR, is used by the TBLRD and TBLWT instructions. These instructions can update the TBLPTR in one of four ways, based on the table operation. These operations are shown in Table 6-1. These operations on the TBLPTR only affect the low order 21 bits.

6.2.4 TABLE POINTER BOUNDARIES

TBLPTR is used in reads, writes, and erases of the FLASH program memory.

When a TBLRD is executed, all 22 bits of the Table Pointer determine which byte is read from program or configuration memory into TABLAT.

When a TBLWT is executed, the three LSBs of the Table Pointer (TBLPTR<2:0>) determine which of the eight program memory holding registers is written to. When the timed write to program memory (long write) begins, the 19 MSBs of the Table Pointer, TBLPTR (TBLPTR<21:3>), will determine which program memory block of 8 bytes is written to (TBLPTR<2:0> are ignored). For more detail, see Section 6.5 ("Writing to FLASH Program Memory").

When an erase of program memory is executed, the 16 MSBs of the Table Pointer (TBLPTR<21:6>) point to the 64-byte block that will be erased. The Least Significant bits (TBLPTR<5:0>) are ignored.

Figure 6-3 describes the relevant boundaries of TBLPTR based on FLASH program memory operations.

TABLE 6-1: TABLE POINTER OPERATIONS WITH TBLRD AND TBLWT INSTRUCTIONS

Example	Operation on Table Pointer
TBLRD* TBLWT*	TBLPTR is not modified
TBLRD*+ TBLWT*+	TBLPTR is incremented after the read/write
TBLRD*- TBLWT*-	TBLPTR is decremented after the read/write
TBLRD+* TBLWT+*	TBLPTR is incremented before the read/write

FIGURE 6-3: TABLE POINTER BOUNDARIES BASED ON OPERATION

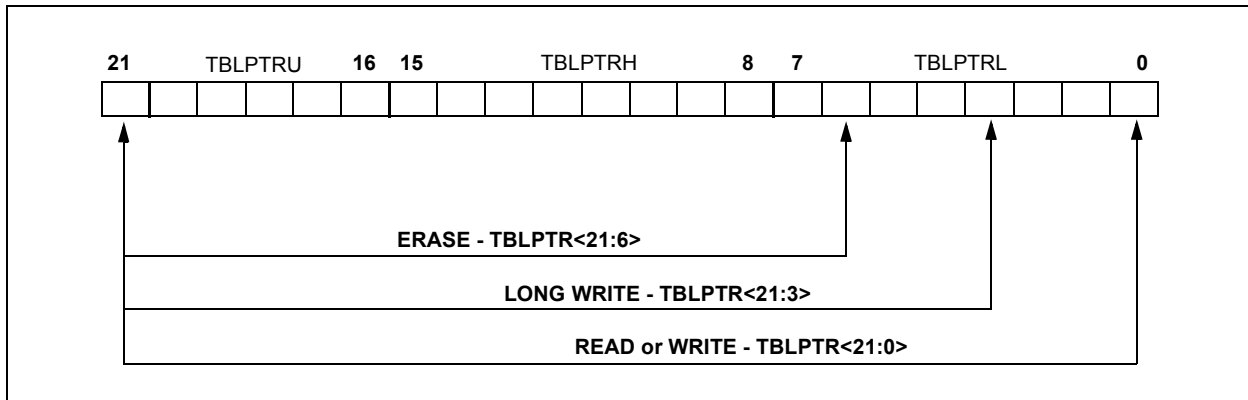

6.3 Reading the FLASH Program Memory

The `TBLRD` instruction is used to retrieve data from program memory and place into data RAM. Table Reads from program memory are performed one byte at a time.

`TBLPTR` points to a byte address in program space. Executing a `TBLRD` instruction places the byte pointed to into `TABLAT`. In addition, `TBLPTR` can be modified automatically for the next Table Read operation.

The internal program memory is typically organized by words. The Least Significant bit of the address selects between the high and low bytes of the word. Figure 6-4 shows the interface between the internal program memory and the `TABLAT`.

FIGURE 6-4: READS FROM FLASH PROGRAM MEMORY

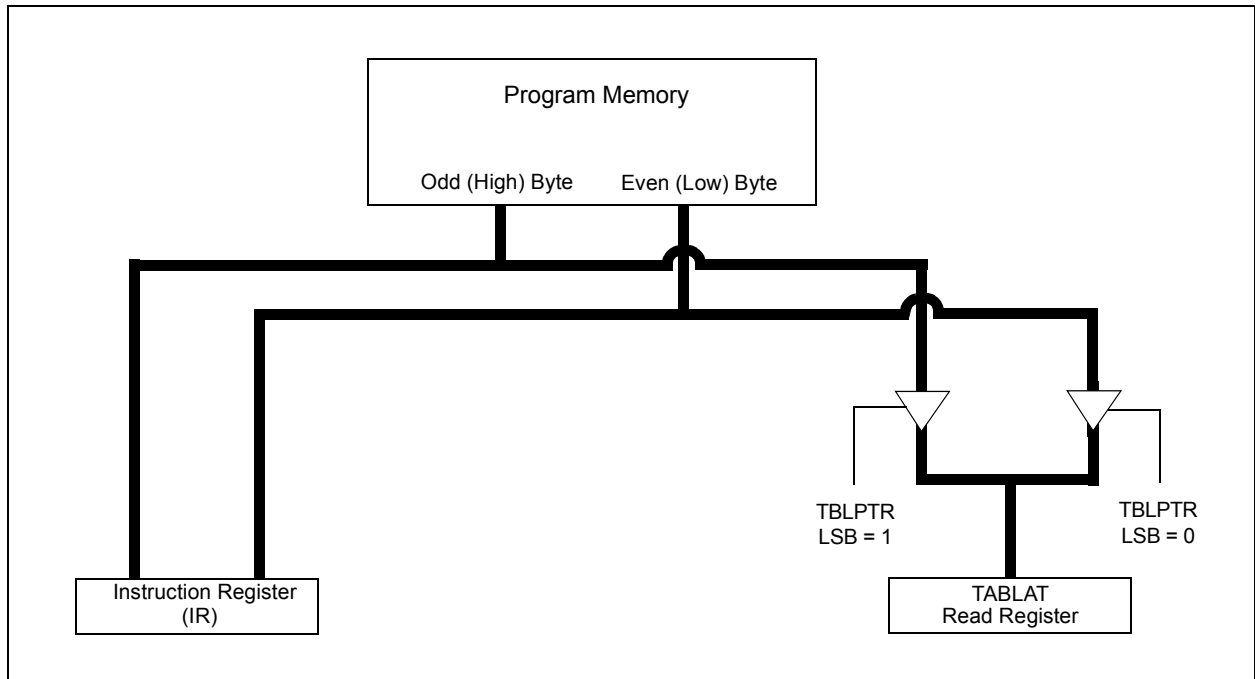

EXAMPLE 6-1: READING A FLASH PROGRAM MEMORY WORD

```

MOV LW  CODE_ADDR_UPPER      ; Load TBLPTR with the base
MOV WF  TBLPTRU              ; address of the word
MOV LW  CODE_ADDR_HIGH
MOV WF  TBLPTRH
MOV LW  CODE_ADDR_LOW
MOV WF  TBLPTRL

READ_WORD
TBLRD*+                      ; read into TABLAT and increment TBLPTR
MOV FW  TABLAT               ; get data
MOV WF  WORD_EVEN
TBLRD*+                      ; read into TABLAT and increment TBLPTR
MOV FW  TABLAT               ; get data
MOV WF  WORD_ODD
    
```

PIC18F1220/1320

6.4 Erasing FLASH Program Memory

The minimum erase block size is 32 words or 64 bytes under firmware control. Only through the use of an external programmer, or through ICSP control, can larger blocks of program memory be bulk erased. Word erase in FLASH memory is not supported.

When initiating an erase sequence from the microcontroller itself, a block of 64 bytes of program memory is erased. The Most Significant 16 bits of the TBLPTR<21:6> point to the block being erased. TBLPTR<5:0> are ignored.

The EECON1 register commands the erase operation. The EEPGD bit must be set to point to the FLASH program memory. The CFGS bit must be clear to access program FLASH and data EEPROM memory. The WREN bit must be set to enable write operations. The FREE bit is set to select an erase operation. The WR bit is set as part of the required instruction sequence (as shown in Example 6-2), and starts the actual erase operation. It is not necessary to load the TABLAT register with any data as it is ignored.

For protection, the write initiate sequence using EECON2 must be used.

A long write is necessary for erasing the internal FLASH. Instruction execution is halted while in a long write cycle. The long write will be terminated by the internal programming timer.

6.4.1 FLASH PROGRAM MEMORY ERASE SEQUENCE

The sequence of events for erasing a block of internal program memory location is:

1. Load table pointer with address of row being erased.
2. Set the EECON1 register for the erase operation:
 - set EEPGD bit to point to program memory;
 - clear the CFGS bit to access program memory;
 - set WREN bit to enable writes;
 - set FREE bit to enable the erase.
3. Disable interrupts.
4. Write 55h to EECON2.
5. Write AAh to EECON2.
6. Set the WR bit. This will begin the row erase cycle.
7. The CPU will stall for duration of the erase (about 2 ms using internal timer).
8. Execute a NOP.
9. Re-enable interrupts.

EXAMPLE 6-2: ERASING A FLASH PROGRAM MEMORY ROW

	MOVLW	CODE_ADDR_UPPER	; load TBLPTR with the base
	MOVWF	TBLPTRU	; address of the memory block
	MOVLW	CODE_ADDR_HIGH	
	MOVWF	TBLPTRH	
	MOVLW	CODE_ADDR_LOW	
	MOVWF	TBLPTRL	
ERASE_ROW			
	BSF	EECON1,EEPGD	; point to FLASH program memory
	BSF	EECON1,WREN	; enable write to memory
	BSF	EECON1,FREE	; enable Row Erase operation
	BCF	INTCON,GIE	; disable interrupts
Required Sequence	MOVLW	55h	
	MOVWF	EECON2	; write 55H
	MOVLW	AAh	
	MOVWF	EECON2	; write AAH
	BSF	EECON1,WR	; start erase (CPU stall)
	NOP		
	BSF	INTCON,GIE	; re-enable interrupts

6.5 Writing to FLASH Program Memory

The programming block size is 4 words or 8 bytes. Word or byte programming is not supported.

Table Writes are used internally to load the holding registers needed to program the FLASH memory. There are 8 holding registers used by the Table Writes for programming.

Since the Table Latch (TABLAT) is only a single byte, the `TBLWT` instruction has to be executed 8 times for each programming operation. All of the Table Write operations will essentially be short writes, because only the holding registers are written. At the end of updating 8 registers, the `EECON1` register must be written to, to start the programming operation with a long write.

The long write is necessary for programming the internal FLASH. Instruction execution is halted while in a long write cycle. The long write will be terminated by the internal programming timer.

FIGURE 6-5: TABLE WRITES TO FLASH PROGRAM MEMORY

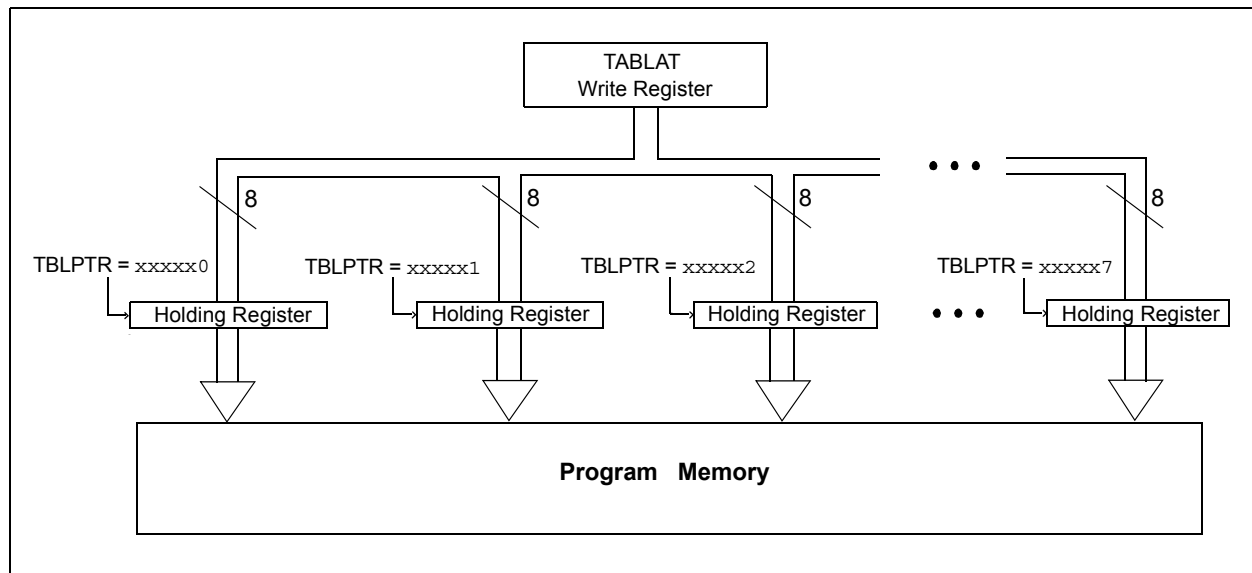

6.5.1 FLASH PROGRAM MEMORY WRITE SEQUENCE

The sequence of events for programming an internal program memory location should be:

1. Read 64 bytes into RAM.
2. Update data values in RAM as necessary.
3. Load Table Pointer with address being erased.
4. Do the row erase procedure (see Section 6.4.1).
5. Load Table Pointer with address of first byte being written.
6. Write the first 8 bytes into the holding registers with auto-increment.
7. Set the `EECON1` register for the write operation:
 - set `EEPGD` bit to point to program memory;
 - clear the `CFGFS` bit to access program memory;
 - set `WREN` bit to enable byte writes.
8. Disable interrupts.
9. Write 55h to `EECON2`.
10. Write AAh to `EECON2`.
11. Set the `WR` bit. This will begin the write cycle.
12. The CPU will stall for duration of the write (about 2 ms using internal timer).
13. Execute a `NOE`.
14. Re-enable interrupts.
15. Repeat steps 6-14 seven times, to write 64 bytes.
16. Verify the memory (Table Read).

This procedure will require about 18 ms to update one row of 64 bytes of memory. An example of the required code is given in Example 6-3.

PIC18F1220/1320

EXAMPLE 6-3: WRITING TO FLASH PROGRAM MEMORY

```
        MOVLW    D'64                ; number of bytes in erase block
        MOVWF    COUNTER
        MOVLW    BUFFER_ADDR_HIGH    ; point to buffer
        MOVWF    FSR0H
        MOVLW    BUFFER_ADDR_LOW
        MOVWF    FSR0L
        MOVLW    CODE_ADDR_UPPER     ; Load TBLPTR with the base
        MOVWF    TBLPTRU             ; address of the memory block
        MOVLW    CODE_ADDR_HIGH
        MOVWF    TBLPTRH
        MOVLW    CODE_ADDR_LOW
        MOVWF    TBLPTRL             ; 6 LSB = 0
        MOVWF    TBLPTRL

READ_BLOCK
        TBLRD*+                       ; read into TABLAT, and inc
        MOVF     TABLAT, W             ; get data
        MOVWF    POSTINC0             ; store data and increment FSR0
        DECFSZ  COUNTER              ; done?
        GOTO     READ_BLOCK           ; repeat

MODIFY_WORD
        MOVLW    DATA_ADDR_HIGH     ; point to buffer
        MOVWF    FSR0H
        MOVLW    DATA_ADDR_LOW
        MOVWF    FSR0L
        MOVLW    NEW_DATA_LOW        ; update buffer word and increment FSR0
        MOVWF    POSTINC0
        MOVLW    NEW_DATA_HIGH
        MOVWF    INDF0               ; update buffer word

ERASE_BLOCK
        MOVLW    CODE_ADDR_UPPER     ; load TBLPTR with the base
        MOVWF    TBLPTRU             ; address of the memory block
        MOVLW    CODE_ADDR_HIGH
        MOVWF    TBLPTRH
        MOVLW    CODE_ADDR_LOW
        MOVWF    TBLPTRL             ; 6 LSB = 0
        MOVWF    TBLPTRL
        BCF     EECON1,CFGFS         ; point to PROG/EEPROM memory
        BSF     EECON1,EEPGD         ; point to FLASH program memory
        BSF     EECON1,WREN          ; enable write to memory
        BSF     EECON1,FREE          ; enable Row Erase operation
        BCF     INTCON,GIE           ; disable interrupts
        MOVLW    55h                 ; Required sequence
        MOVWF    EECON2              ; write 55H
        MOVLW    AAh
        MOVWF    EECON2              ; write AAH
        BSF     EECON1,WR             ; start erase (CPU stall)
        NOP
        BSF     INTCON,GIE           ; re-enable interrupts

WRITE_BUFFER_BACK
        MOVLW    8                    ; number of write buffer groups of 8 bytes
        MOVWF    COUNTER_HI
        MOVLW    BUFFER_ADDR_HIGH    ; point to buffer
        MOVWF    FSR0H
        MOVLW    BUFFER_ADDR_LOW
        MOVWF    FSR0L

PROGRAM_LOOP
        MOVLW    8                    ; number of bytes in holding register
        MOVWF    COUNTER

WRITE_WORD_TO_HREGS
        MOVF     POSTINC0, W          ; get low byte of buffer data and increment FSR0
        MOVWF    TABLAT              ; present data to table latch
        TBLWT*+                       ; short write
        ; to internal TBLWT holding register, increment
        TBLPTR
        DECFSZ  COUNTER              ; loop until buffers are full
        GOTO     WRITE_WORD_TO_HREGS
```

EXAMPLE 6-3: WRITING TO FLASH PROGRAM MEMORY (CONTINUED)

```

PROGRAM_MEMORY
    BCF    INTCON,GIE           ; disable interrupts
    MOVLW  55h                 ; required sequence
    MOVWF  EECON2              ; write 55H
    MOVLW  AAh
    MOVWF  EECON2              ; write AAH
    BSF    EECON1,WR           ; start program (CPU stall)
    NOP
    BSF    INTCON,GIE         ; re-enable interrupts
    DECFSZ COUNTER_HI         ; loop until done
    GOTO  PROGRAM_LOOP
    BCF    EECON1,WREN        ; disable write to memory
    
```

6.5.2 WRITE VERIFY

Depending on the application, good programming practice may dictate that the value written to the memory should be verified against the original value. This should be used in applications where excessive writes can stress bits near the specification limit.

6.5.3 UNEXPECTED TERMINATION OF WRITE OPERATION

If a write is terminated by an unplanned event, such as loss of power or an unexpected RESET, the memory location just programmed should be verified and reprogrammed if needed. The WRERR bit is set when a write operation is interrupted by a MCLR Reset, or a WDT Time-out Reset during normal operation. In these situations, users can check the WRERR bit and rewrite the location.

6.6 FLASH Program Operation During Code Protection

See “Special Features of the CPU” (Section 19.0) for details on code protection of FLASH program memory.

TABLE 6-2: REGISTERS ASSOCIATED WITH PROGRAM FLASH MEMORY

Name	Bit 7	Bit 6	Bit 5	Bit 4	Bit 3	Bit 2	Bit 1	Bit 0	Value on: POR, BOR	Value on all other RESETS
TBLPTRU	—	—	bit21	Program Memory Table Pointer Upper Byte (TBLPTR<20:16>)					--00 0000	--00 0000
TBPLTRH	Program Memory Table Pointer High Byte (TBLPTR<15:8>)								0000 0000	0000 0000
TBLPTRL	Program Memory Table Pointer High Byte (TBLPTR<7:0>)								0000 0000	0000 0000
TABLAT	Program Memory Table Latch								0000 0000	0000 0000
INTCON	GIE/GIEH	PEIE/GIEL	TMR0IE	INTE	RBIE	TMR0IF	INTF	RBIF	0000 000x	0000 000u
EECON2	EEPROM Control Register2 (not a physical register)								—	—
EECON1	EEPGD	CFGS	—	FREE	WRERR	WREN	WR	RD	xx-0 x000	uu-0 u000
IPR2	OSCFIP	—	—	EEIP	—	LVDIP	TMR3IP	—	1--1 1111	1--1 1111
PIR2	OSCFIF	—	—	EEIF	—	LVDIF	TMR3IF	—	0--0 0000	0--0 0000
PIE2	OSCFIE	—	—	EEIE	—	LVDIE	TMR3IE	—	0--0 0000	0--0 0000

Legend: x = unknown, u = unchanged, r = reserved, - = unimplemented, read as '0'.
Shaded cells are not used during FLASH/EEPROM access.

PIC18F1220/1320

NOTES:

7.0 DATA EEPROM MEMORY

The Data EEPROM is readable and writable during normal operation over the entire V_{DD} range. The data memory is not directly mapped in the register file space. Instead, it is indirectly addressed through the Special Function Registers (SFR).

There are four SFRs used to read and write the program and data EEPROM memory. These registers are:

- EECON1
- EECON2
- EEDATA
- EEADR

The EEPROM data memory allows byte read and write. When interfacing to the data memory block, EEDATA holds the 8-bit data for read/write and EEADR holds the address of the EEPROM location being accessed. These devices have 256 bytes of data EEPROM with an address range from 00h to FFh.

The EEPROM data memory is rated for high erase/write cycle endurance. A byte write automatically erases the location and writes the new data (erase-before-write). The write time is controlled by an on-chip timer. The write time will vary with voltage and temperature, as well as from chip to chip. Please refer to parameter D122 (Table 22-1 in the "Electrical Characteristics" section) for exact limits.

7.1 EEADR

The address register can address 256 bytes of data EEPROM.

7.2 EECON1 and EECON2 Registers

EECON1 is the control register for memory accesses.

EECON2 is not a physical register. Reading EECON2 will read all '0's. The EECON2 register is used exclusively in the memory write and erase sequences.

Control bit EEPGD determines if the access will be to program or data EEPROM memory. When clear, operations will access the data EEPROM memory. When set, program memory is accessed.

Control bit CFGS determines if the access will be to the configuration registers or to program memory/data EEPROM memory. When set, subsequent operations access configuration registers. When CFGS is clear, the EEPGD bit selects either program FLASH, or Data EEPROM memory.

The WREN bit enables and disables erase and write operations. When set, erase and write operations are allowed. When clear, erase and write operations are disabled – the WR bit cannot be set while the WREN bit is clear. This mechanism helps to prevent accidental writes to memory due to errant (unexpected) code execution.

Firmware should keep the WREN bit clear at all times, except when starting erase or write operations. Once firmware has set the WR bit, the WREN bit may be cleared. Clearing the WREN bit will not affect the operation in progress.

The WRERR bit is set when a write operation is interrupted by a RESET. In these situations, the user can check the WRERR bit and rewrite the location. It is necessary to reload the data and address registers (EEDATA and EEADR), as these registers have cleared as a result of the RESET.

Control bits, RD and WR, start read and erase/write operations, respectively. These bits are set by firmware, and cleared by hardware at the completion of the operation.

The RD bit cannot be set when accessing program memory (EEPGD = 1). Program memory is read using Table Read instructions. See Section 6.1 regarding Table Reads.

Note: Interrupt flag bit, EEIF in the PIR2 register, is set when write is complete. It must be cleared in software.

PIC18F1220/1320

REGISTER 7-1: EECON1 REGISTER

R/W-x	R/W-x	U-0	R/W-0	R/W-x	R/W-0	R/S-0	R/S-0
EEPGD	CFGS	—	FREE	WRERR	WREN	WR	RD
bit 7						bit 0	

- bit 7 **EEPGD:** FLASH Program or Data EEPROM Memory Select bit
 1 = Access program FLASH memory
 0 = Access data EEPROM memory
- bit 6 **CFGS:** FLASH Program/Data EE or Configuration Select bit
 1 = Access configuration or calibration registers
 0 = Access program FLASH or data EEPROM memory
- bit 5 **Unimplemented:** Read as '0'
- bit 4 **FREE:** FLASH Row Erase Enable bit
 1 = Erase the program memory row addressed by TBLPTR on the next WR command
 (cleared by completion of erase operation)
 0 = Perform write only
- bit 3 **WRERR:** EEPROM Error Flag bit
 1 = A write operation was prematurely terminated
 (MCLR or WDT Reset during self-timed erase or program operation)
 0 = The write operation completed normally
Note: When a WRERR occurs, the EEGPD or FREE bits are not cleared. This allows tracing of the error condition.
- bit 2 **WREN:** Erase/Write Enable bit
 1 = Allows erase/write cycles
 0 = Inhibits erase/write cycles
- bit 1 **WR:** Write Control bit
 1 = Initiates a data EEPROM erase/write cycle, or a program memory erase cycle, or write cycle.
 (The operation is self-timed and the bit is cleared by hardware once write is complete. The WR bit can only be set (not cleared) in software.)
 0 = Write cycle is completed
- bit 0 **RD:** Read Control bit
 1 = Initiates a memory read
 (Read takes one cycle. RD is cleared in hardware. The RD bit can only be set (not cleared) in software. RD bit cannot be set when EEGPD = 1.)
 0 = Read completed

Legend:			
R = Readable bit	S = Settable only	U = Unimplemented bit, read as '0'	
W = Writable bit	- n = Value at POR	'1' = Bit is set	'0' = Bit is cleared
x = Bit is unknown			

7.3 Reading the Data EEPROM Memory

To read a data memory location, the user must write the address to the EEADR register, clear the EEPGD control bit (EECON1<7>) and then set control bit RD (EECON1<0>). The data is available for the very next instruction cycle; therefore, the EEDATA register can be read by the next instruction. EEDATA will hold this value until another read operation, or until it is written to by the user (during a write operation).

7.4 Writing to the Data EEPROM Memory

To write an EEPROM data location, the address must first be written to the EEADR register and the data written to the EEDATA register. The sequence in Example 7-2 must be followed to initiate the write cycle.

The write will not begin if this sequence is not exactly followed (write 55h to EECON2, write AAh to EECON2, then set WR bit) for each byte. It is strongly recommended that interrupts be disabled during this code segment.

Additionally, the WREN bit in EECON1 must be set to enable writes. This mechanism prevents accidental writes to data EEPROM due to unexpected code execution (i.e., runaway programs). The WREN bit should be kept clear at all times, except when updating the EEPROM. The WREN bit is not cleared by hardware.

After a write sequence has been initiated, EECON1, EEADR and EEDATA cannot be modified. The WR bit will be inhibited from being set unless the WREN bit is set. The WREN bit must be set on a previous instruction. Both WR and WREN cannot be set with the same instruction.

At the completion of the write cycle, the WR bit is cleared in hardware and the EEPROM Interrupt Flag bit (EEIF) is set. The user may either enable this interrupt, or poll this bit. EEIF must be cleared by software.

7.5 Write Verify

Depending on the application, good programming practice may dictate that the value written to the memory should be verified against the original value. This should be used in applications where excessive writes can stress bits near the specification limit.

7.6 Protection Against Spurious Write

There are conditions when the device may not want to write to the data EEPROM memory. To protect against spurious EEPROM writes, various mechanisms have been built-in. On power-up, the WREN bit is cleared. Also, the Power-up Timer (72 ms duration) prevents EEPROM write.

The write initiate sequence and the WREN bit together help prevent an accidental write during brown-out, power glitch, or software malfunction.

EXAMPLE 7-1: DATA EEPROM READ

```

MOVLW  DATA_EE_ADDR   ;
MOVWF  EEADR           ; Data Memory Address to read
BCF    EECON1, EEPGD   ; Point to DATA memory
BSF    EECON1, RD      ; EEPROM Read
MOVF   EEDATA, W       ; W = EEDATA
    
```

EXAMPLE 7-2: DATA EEPROM WRITE

```

MOVLW  DATA_EE_ADDR   ;
MOVWF  EEADR           ; Data Memory Address to write
MOVLW  DATA_EE_DATA   ;
MOVWF  EEDATA          ; Data Memory Value to write
BCF    EECON1, EEPGD   ; Point to DATA memory
BSF    EECON1, WREN    ; Enable writes
BCF    INTCON, GIE     ; Disable Interrupts
MOVLW  55h             ;
Required MOVWF EECON2    ; Write 55h
Sequence MOVLW AAh      ;
MOVWF  EECON2          ; Write AAh
BSF    EECON1, WR      ; Set WR bit to begin write
BSF    INTCON, GIE     ; Enable Interrupts

SLEEP                               ; Wait for interrupt to signal write complete
BCF    EECON1, WREN    ; Disable writes
    
```

PIC18F1220/1320

7.7 Operation During Code Protect

Data EEPROM memory has its own code protect bits in configuration words. External Read and Write operations are disabled if either of these mechanisms are enabled.

The microcontroller itself can both read and write to the internal Data EEPROM, regardless of the state of the code protect configuration bit. Refer to “Special Features of the CPU” (Section 19.0) for additional information.

7.8 Using the Data EEPROM

The Data EEPROM is a high endurance, byte addressable array that has been optimized for the storage of frequently changing information (e.g., program variables or other data that are updated often). Frequently changing values will typically be updated more often than specification D124 or D124A. If this is not the case, an array refresh must be performed. For this reason, variables that change infrequently (such as constants, IDs, calibration, etc.) should be stored in FLASH program memory.

A simple data EEPROM refresh routine is shown in Example 7-3.

Note: If data EEPROM is only used to store constants and/or data that changes rarely, an array refresh is likely not required. See specification D124 or D124A.

EXAMPLE 7-3: DATA EEPROM REFRESH ROUTINE

```

    clr    EEADR           ; Start at address 0
    bcf    EECON1,CFG5     ; Set for memory
    bcf    EECON1,EEPGD    ; Set for Data EEPROM
    bcf    INTCON,GIE      ; Disable interrupts
    bsf    EECON1,WREN     ; Enable writes
Loop
    bsf    EECON1,RD       ; Loop to refresh array
    movlw 55h              ; Read current address
    movwf EECON2           ; Write 55h
    movlw AAh              ;
    movwf EECON2           ; Write AAh
    bsf    EECON1,WR       ; Set WR bit to begin write
    btfsc EECON1,WR       ; Wait for write to complete
    bra   $-2
    incfsz EEADR,F         ; Increment address
    bra   Loop             ; Not zero, do it again

    bcf    EECON1,WREN     ; Disable writes
    bsf    INTCON,GIE      ; Enable interrupts
    
```

TABLE 7-1: REGISTERS ASSOCIATED WITH DATA EEPROM MEMORY

Name	Bit 7	Bit 6	Bit 5	Bit 4	Bit 3	Bit 2	Bit 1	Bit 0	Value on: POR, BOR	Value on all other RESETS
INTCON	GIE/GIEH	PEIE/GIEL	TMR0IE	INTE	RBIE	TMR0IF	INTF	RBIF	0000 000x	0000 000u
EEADR	EEPROM Address Register								0000 0000	0000 0000
EEDATA	EEPROM Data Register								0000 0000	0000 0000
EECON2	EEPROM Control Register2 (not a physical register)								—	—
EECON1	EEPGD	CFG5	—	FREE	WRERR	WREN	WR	RD	xx-0 x000	uu-0 u000
IPR2	OSCFIP	—	—	EEIP	BCLIP	LVDIP	TMR3IP	CCP2IP	1--1 1111	1--1 1111
PIR2	OSCFIF	—	—	EEIF	BCLIF	LVDIF	TMR3IF	CCP2IF	0--0 0000	0--0 0000
PIE2	OSCFIE	—	—	EEIE	BCLIE	LVDIE	TMR3IE	CCP2IE	0--0 0000	0--0 0000

Legend: x = unknown, u = unchanged, r = reserved, - = unimplemented, read as '0'.

Shaded cells are not used during FLASH/EEPROM access.

8.0 8 X 8 HARDWARE MULTIPLIER

8.1 Introduction

An 8 x 8 hardware multiplier is included in the ALU of the PIC18F1220/1320 devices. By making the multiply a hardware operation, it completes in a single instruction cycle. This is an unsigned multiply that gives a 16-bit result. The result is stored into the 16-bit product register pair (PRODH:PRODL). The multiplier does not affect any flags in the STATUS register.

Making the 8 x 8 multiplier execute in a single cycle gives the following advantages:

- Higher computational throughput
- Reduces code size requirements for multiply algorithms

The performance increase allows the device to be used in applications previously reserved for Digital Signal Processors.

Table 8-1 shows a performance comparison between enhanced devices using the single cycle hardware multiply, and performing the same function without the hardware multiply.

TABLE 8-1: PERFORMANCE COMPARISON

Routine	Multiply Method	Program Memory (Words)	Cycles (Max)	Time		
				@ 40 MHz	@ 10 MHz	@ 4 MHz
8 x 8 unsigned	Without hardware multiply	13	69	6.9 μ s	27.6 μ s	69 μ s
	Hardware multiply	1	1	100 ns	400 ns	1 μ s
8 x 8 signed	Without hardware multiply	33	91	9.1 μ s	36.4 μ s	91 μ s
	Hardware multiply	6	6	600 ns	2.4 μ s	6 μ s
16 x 16 unsigned	Without hardware multiply	21	242	24.2 μ s	96.8 μ s	242 μ s
	Hardware multiply	24	24	2.4 μ s	9.6 μ s	24 μ s
16 x 16 signed	Without hardware multiply	52	254	25.4 μ s	102.6 μ s	254 μ s
	Hardware multiply	36	36	3.6 μ s	14.4 μ s	36 μ s

8.2 Operation

Example 8-1 shows the sequence to do an 8 x 8 unsigned multiply. Only one instruction is required when one argument of the multiply is already loaded in the WREG register.

Example 8-2 shows the sequence to do an 8 x 8 signed multiply. To account for the sign bits of the arguments, each argument's Most Significant bit (MSb) is tested and the appropriate subtractions are done.

EXAMPLE 8-1: 8 x 8 UNSIGNED MULTIPLY ROUTINE

```

MOVWF ARG1, W      ;
MULWF ARG2         ; ARG1 * ARG2 ->
                   ; PRODH:PRODL
    
```

EXAMPLE 8-2: 8 x 8 SIGNED MULTIPLY ROUTINE

```

MOVWF ARG1, W
MULWF ARG2         ; ARG1 * ARG2 ->
                   ; PRODH:PRODL

BTFSC ARG2, SB    ; Test Sign Bit
SUBWF PRODH, F    ; PRODH = PRODH
                   ; - ARG1

MOVWF ARG2, W
BTFSC ARG1, SB    ; Test Sign Bit
SUBWF PRODH, F    ; PRODH = PRODH
                   ; - ARG2
    
```

PIC18F1220/1320

Example 8-3 shows the sequence to do a 16 x 16 unsigned multiply. Equation 8-1 shows the algorithm that is used. The 32-bit result is stored in four registers, RES3:RES0.

EQUATION 8-1: 16 x 16 UNSIGNED MULTIPLICATION ALGORITHM

$$\begin{aligned} \text{RES3:RES0} &= \text{ARG1H:ARG1L} \cdot \text{ARG2H:ARG2L} \\ &= (\text{ARG1H} \cdot \text{ARG2H} \cdot 2^{16}) + \\ &\quad (\text{ARG1H} \cdot \text{ARG2L} \cdot 2^8) + \\ &\quad (\text{ARG1L} \cdot \text{ARG2H} \cdot 2^8) + \\ &\quad (\text{ARG1L} \cdot \text{ARG2L}) \end{aligned}$$

EXAMPLE 8-3: 16 x 16 UNSIGNED MULTIPLY ROUTINE

```

MOVF ARG1L, W
MULWF ARG2L ; ARG1L * ARG2L ->
; PRODH:PRODL

MOVFF PRODH, RES1 ;
MOVFF PRODL, RES0 ;
;

MOVF ARG1H, W
MULWF ARG2H ; ARG1H * ARG2H ->
; PRODH:PRODL

MOVFF PRODH, RES3 ;
MOVFF PRODL, RES2 ;
;

MOVF ARG1L, W
MULWF ARG2H ; ARG1L * ARG2H ->
; PRODH:PRODL

MOVF PRODL, W ;
ADDWF RES1, F ; Add cross
MOVF PRODH, W ; products
ADDWFC RES2, F ;
CLRF WREG ;
ADDWFC RES3, F ;
;

MOVF ARG1H, W ;
MULWF ARG2L ; ARG1H * ARG2L ->
; PRODH:PRODL

MOVF PRODL, W ;
ADDWF RES1, F ; Add cross
MOVF PRODH, W ; products
ADDWFC RES2, F ;
CLRF WREG ;
ADDWFC RES3, F ;

```

Example 8-4 shows the sequence to do a 16 x 16 signed multiply. Equation 8-2 shows the algorithm used. The 32-bit result is stored in four registers, RES3:RES0. To account for the sign bits of the arguments, each argument pairs' Most Significant bit (MSb) is tested and the appropriate subtractions are done.

EQUATION 8-2: 16 x 16 SIGNED MULTIPLICATION ALGORITHM

$$\begin{aligned} \text{RES3:RES0} &= \text{ARG1H:ARG1L} \cdot \text{ARG2H:ARG2L} \\ &= (\text{ARG1H} \cdot \text{ARG2H} \cdot 2^{16}) + \\ &\quad (\text{ARG1H} \cdot \text{ARG2L} \cdot 2^8) + \\ &\quad (\text{ARG1L} \cdot \text{ARG2H} \cdot 2^8) + \\ &\quad (\text{ARG1L} \cdot \text{ARG2L}) + \\ &\quad (-1 \cdot \text{ARG2H} < 7 > \cdot \text{ARG1H:ARG1L} \cdot 2^{16}) + \\ &\quad (-1 \cdot \text{ARG1H} < 7 > \cdot \text{ARG2H:ARG2L} \cdot 2^{16}) \end{aligned}$$

EXAMPLE 8-4: 16 x 16 SIGNED MULTIPLY ROUTINE

```

MOVF ARG1L, W
MULWF ARG2L ; ARG1L * ARG2L ->
; PRODH:PRODL

MOVFF PRODH, RES1 ;
MOVFF PRODL, RES0 ;
;

MOVF ARG1H, W
MULWF ARG2H ; ARG1H * ARG2H ->
; PRODH:PRODL

MOVFF PRODH, RES3 ;
MOVFF PRODL, RES2 ;
;

MOVF ARG1L, W
MULWF ARG2H ; ARG1L * ARG2H ->
; PRODH:PRODL

MOVF PRODL, W ;
ADDWF RES1, F ; Add cross
MOVF PRODH, W ; products
ADDWFC RES2, F ;
CLRF WREG ;
ADDWFC RES3, F ;
;

MOVF ARG1H, W ;
MULWF ARG2L ; ARG1H * ARG2L ->
; PRODH:PRODL

MOVF PRODL, W ;
ADDWF RES1, F ; Add cross
MOVF PRODH, W ; products
ADDWFC RES2, F ;
CLRF WREG ;
ADDWFC RES3, F ;
;

BTFS ARG2H, 7 ; ARG2H:ARG2L neg?
BRA SIGN_ARG1 ; no, check ARG1
MOVF ARG1L, W ;
SUBWF RES2 ;
MOVF ARG1H, W ;
SUBWFB RES3 ;
;

SIGN_ARG1
BTFS ARG1H, 7 ; ARG1H:ARG1L neg?
BRA CONT_CODE ; no, done
MOVF ARG2L, W ;
SUBWF RES2 ;
MOVF ARG2H, W ;
SUBWFB RES3 ;
;

CONT_CODE
:

```

9.0 INTERRUPTS

The PIC18F1220/1320 devices have multiple interrupt sources and an interrupt priority feature that allows each interrupt source to be assigned a high priority level or a low priority level. The high priority interrupt vector is at 000008h and the low priority interrupt vector is at 000018h. High priority interrupt events will interrupt any low priority interrupts that may be in progress.

There are ten registers which are used to control interrupt operation. These registers are:

- RCON
- INTCON
- INTCON2
- INTCON3
- PIR1, PIR2
- PIE1, PIE2
- IPR1, IPR2

It is recommended that the Microchip header files supplied with MPLAB® IDE be used for the symbolic bit names in these registers. This allows the assembler/compiler to automatically take care of the placement of these bits within the specified register.

Each interrupt source has three bits to control its operation. The functions of these bits are:

- Flag bit to indicate that an interrupt event occurred
- Enable bit that allows program execution to branch to the interrupt vector address when the flag bit is set
- Priority bit to select high priority or low priority

The interrupt priority feature is enabled by setting the IPEN bit (RCON<7>). When interrupt priority is enabled, there are two bits which enable interrupts globally. Setting the GIEH bit (INTCON<7>) enables all interrupts that have the priority bit set (high priority). Setting the GIEL bit (INTCON<6>) enables all interrupts that have the priority bit cleared (low priority). When the interrupt flag, enable bit and appropriate global interrupt enable bit are set, the interrupt will vector immediately to address 000008h or 000018h, depending on the priority bit setting. Individual interrupts can be disabled through their corresponding enable bits.

When the IPEN bit is cleared (default state), the interrupt priority feature is disabled and interrupts are compatible with PICmicro® mid-range devices. In Compatibility mode, the interrupt priority bits for each source have no effect. INTCON<6> is the PEIE bit, which enables/disables all peripheral interrupt sources. INTCON<7> is the GIE bit, which enables/disables all interrupt sources. All interrupts branch to address 000008h in Compatibility mode.

When an interrupt is responded to, the Global Interrupt Enable bit is cleared to disable further interrupts. If the IPEN bit is cleared, this is the GIE bit. If interrupt priority levels are used, this will be either the GIEH or GIEL bit. High priority interrupt sources can interrupt a low priority interrupt. Low priority interrupts are not processed while high priority interrupts are in progress.

The return address is pushed onto the stack and the PC is loaded with the interrupt vector address (000008h or 000018h). Once in the Interrupt Service Routine, the source(s) of the interrupt can be determined by polling the interrupt flag bits. The interrupt flag bits must be cleared in software before re-enabling interrupts to avoid recursive interrupts.

The "return from interrupt" instruction, RETFIE, exits the interrupt routine and sets the GIE bit (GIEH or GIEL, if priority levels are used), which re-enables interrupts.

For external interrupt events, such as the INT pins or the PORTB input change interrupt, the interrupt latency will be three to four instruction cycles. The exact latency is the same for one or two-cycle instructions. Individual interrupt flag bits are set, regardless of the status of their corresponding enable bit, or the GIE bit.

Note: Do not use the MOVFF instruction to modify any of the interrupt control registers while **any** interrupt is enabled. Doing so may cause erratic microcontroller behavior.

PIC18F1220/1320

FIGURE 9-1: INTERRUPT LOGIC

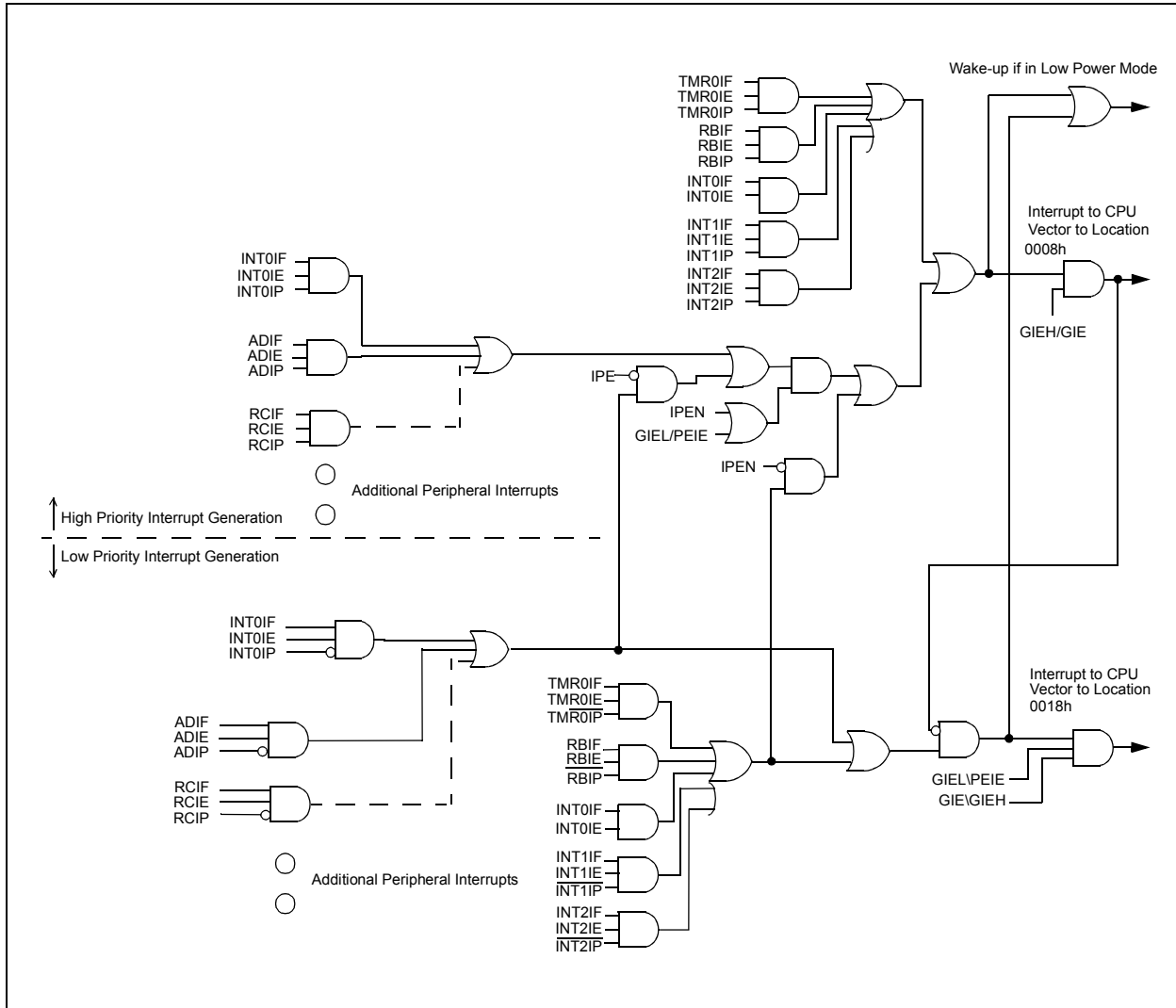

9.1 INTCON Registers

The INTCON Registers are readable and writable registers, which contain various enable, priority and flag bits.

Note: Interrupt flag bits are set when an interrupt condition occurs, regardless of the state of its corresponding enable bit or the global enable bit. User software should ensure the appropriate interrupt flag bits are clear prior to enabling an interrupt. This feature allows for software polling.

REGISTER 9-1: INTCON REGISTER

R/W-0	R/W-0	R/W-0	R/W-0	R/W-0	R/W-0	R/W-0	R/W-x
GIE/GIEH	PEIE/GIEL	TMR0IE	INT0IE	RBIE	TMR0IF	INT0IF	RBIF
bit 7							bit 0

- bit 7 **GIE/GIEH:** Global Interrupt Enable bit
When IPEN = 0:
 1 = Enables all unmasked interrupts
 0 = Disables all interrupts
When IPEN = 1:
 1 = Enables all high priority interrupts
 0 = Disables all interrupts
 - bit 6 **PEIE/GIEL:** Peripheral Interrupt Enable bit
When IPEN = 0:
 1 = Enables all unmasked peripheral interrupts
 0 = Disables all peripheral interrupts
When IPEN = 1:
 1 = Enables all low priority peripheral interrupts
 0 = Disables all low priority peripheral interrupts
 - bit 5 **TMR0IE:** TMR0 Overflow Interrupt Enable bit
 1 = Enables the TMR0 overflow interrupt
 0 = Disables the TMR0 overflow interrupt
 - bit 4 **INT0IE:** INT0 External Interrupt Enable bit
 1 = Enables the INT0 external interrupt
 0 = Disables the INT0 external interrupt
 - bit 3 **RBIE:** RB Port Change Interrupt Enable bit
 1 = Enables the RB port change interrupt
 0 = Disables the RB port change interrupt
 - bit 2 **TMR0IF:** TMR0 Overflow Interrupt Flag bit
 1 = TMR0 register has overflowed (must be cleared in software)
 0 = TMR0 register did not overflow
 - bit 1 **INT0IF:** INT0 External Interrupt Flag bit
 1 = The INT0 external interrupt occurred (must be cleared in software)
 0 = The INT0 external interrupt did not occur
 - bit 0 **RBIF:** RB Port Change Interrupt Flag bit
 1 = At least one of the RB7:RB4 pins changed state (must be cleared in software)
 0 = None of the RB7:RB4 pins have changed state
- Note:** A mismatch condition will continue to set this bit. Reading PORTB will end the mismatch condition and allow the bit to be cleared.

Legend:

R = Readable bit	W = Writable bit	U = Unimplemented bit, read as '0'
- n = Value at POR	'1' = Bit is set	'0' = Bit is cleared x = Bit is unknown

PIC18F1220/1320

REGISTER 9-2: INTCON2 REGISTER

R/W-1	R/W-1	R/W-1	R/W-1	U-0	R/W-1	U-0	R/W-1
$\overline{\text{RBP}}\text{U}$	INTEDG0	INTEDG1	INTEDG2	—	TMR0IP	—	RBIP
bit 7							bit 0

- bit 7 **RBP**U: PORTB Pull-up Enable bit
 1 = All PORTB pull-ups are disabled
 0 = PORTB pull-ups are enabled by individual port latch values
- bit 6 **INTEDG0**: External Interrupt0 Edge Select bit
 1 = Interrupt on rising edge
 0 = Interrupt on falling edge
- bit 5 **INTEDG1**: External Interrupt1 Edge Select bit
 1 = Interrupt on rising edge
 0 = Interrupt on falling edge
- bit 4 **INTEDG2**: External Interrupt2 Edge Select bit
 1 = Interrupt on rising edge
 0 = Interrupt on falling edge
- bit 3 **Unimplemented**: Read as '0'
- bit 2 **TMR0IP**: TMR0 Overflow Interrupt Priority bit
 1 = High priority
 0 = Low priority
- bit 1 **Unimplemented**: Read as '0'
- bit 0 **RBIP**: RB Port Change Interrupt Priority bit
 1 = High priority
 0 = Low priority

Legend:

R = Readable bit W = Writable bit U = Unimplemented bit, read as '0'
 - n = Value at POR '1' = Bit is set '0' = Bit is cleared x = Bit is unknown

Note: Interrupt flag bits are set when an interrupt condition occurs, regardless of the state of its corresponding enable bit or the global enable bit. User software should ensure the appropriate interrupt flag bits are clear prior to enabling an interrupt. This feature allows for software polling.

REGISTER 9-3: INTCON3 REGISTER

R/W-1	R/W-1	U-0	R/W-0	R/W-0	U-0	R/W-0	R/W-0	
INT2IP	INT1IP	—	INT2IE	INT1IE	—	INT2IF	INT1IF	
bit 7								bit 0

- bit 7 **INT2IP:** INT2 External Interrupt Priority bit
1 = High priority
0 = Low priority
- bit 6 **INT1IP:** INT1 External Interrupt Priority bit
1 = High priority
0 = Low priority
- bit 5 **Unimplemented:** Read as '0'
- bit 4 **INT2IE:** INT2 External Interrupt Enable bit
1 = Enables the INT2 external interrupt
0 = Disables the INT2 external interrupt
- bit 3 **INT1IE:** INT1 External Interrupt Enable bit
1 = Enables the INT1 external interrupt
0 = Disables the INT1 external interrupt
- bit 2 **Unimplemented:** Read as '0'
- bit 1 **INT2IF:** INT2 External Interrupt Flag bit
1 = The INT2 external interrupt occurred (must be cleared in software)
0 = The INT2 external interrupt did not occur
- bit 0 **INT1IF:** INT1 External Interrupt Flag bit
1 = The INT1 external interrupt occurred (must be cleared in software)
0 = The INT1 external interrupt did not occur

Legend:			
R = Readable bit	W = Writable bit	U = Unimplemented bit, read as '0'	
- n = Value at POR	'1' = Bit is set	'0' = Bit is cleared	x = Bit is unknown

Note: Interrupt flag bits are set when an interrupt condition occurs, regardless of the state of its corresponding enable bit or the global enable bit. User software should ensure the appropriate interrupt flag bits are clear prior to enabling an interrupt. This feature allows for software polling.

PIC18F1220/1320

9.2 PIR Registers

The PIR registers contain the individual flag bits for the peripheral interrupts. Due to the number of peripheral interrupt sources, there are two Peripheral Interrupt Flag Registers (PIR1, PIR2).

Note 1: Interrupt flag bits are set when an interrupt condition occurs, regardless of the state of its corresponding enable bit or the global enable bit, GIE (INTCON<7>).

2: User software should ensure the appropriate interrupt flag bits are cleared prior to enabling an interrupt, and after servicing that interrupt.

REGISTER 9-4: PIR1: PERIPHERAL INTERRUPT REQUEST (FLAG) REGISTER 1

U-0	R/W-0	R-0	R-0	U-0	R/W-0	R/W-0	R/W-0
—	ADIF	RCIF	TXIF	—	CCP1IF	TMR2IF	TMR1IF
bit 7							bit 0

bit 7 **Unimplemented:** Read as '0'

bit 6 **ADIF:** A/D Converter Interrupt Flag bit
 1 = An A/D conversion completed (must be cleared in software)
 0 = The A/D conversion is not complete

bit 5 **RCIF:** USART Receive Interrupt Flag bit
 1 = The USART receive buffer, RCREG, is full (cleared when RCREG is read)
 0 = The USART receive buffer is empty

bit 4 **TXIF:** USART Transmit Interrupt Flag bit
 1 = The USART transmit buffer, TXREG, is empty (cleared when TXREG is written)
 0 = The USART transmit buffer is full

bit 3 **Unimplemented:** Read as '0'

bit 2 **CCP1IF:** CCP1 Interrupt Flag bit
Capture mode:
 1 = A TMR1 register capture occurred (must be cleared in software)
 0 = No TMR1 register capture occurred

Compare mode:
 1 = A TMR1 register compare match occurred (must be cleared in software)
 0 = No TMR1 register compare match occurred

PWM mode:
 Unused in this mode

bit 1 **TMR2IF:** TMR2 to PR2 Match Interrupt Flag bit
 1 = TMR2 to PR2 match occurred (must be cleared in software)
 0 = No TMR2 to PR2 match occurred

bit 0 **TMR1IF:** TMR1 Overflow Interrupt Flag bit
 1 = TMR1 register overflowed (must be cleared in software)
 0 = TMR1 register did not overflow

Legend:			
R = Readable bit	W = Writable bit	U = Unimplemented bit, read as '0'	
- n = Value at POR	'1' = Bit is set	'0' = Bit is cleared	x = Bit is unknown

REGISTER 9-5: PIR2: PERIPHERAL INTERRUPT REQUEST (FLAG) REGISTER 2

R/W-0	U-0	U-0	R/W-0	U-0	R/W-0	R/W-0	U-0
OSCFIF	—	—	EEIF	—	LVDIF	TMR3IF	—
bit 7						bit 0	

- bit 7 **OSCFIF:** Oscillator Fail Interrupt Flag bit
 1 = System oscillator failed, clock input has changed to INTOSC (must be cleared in software)
 0 = System clock operating
- bit 6-5 **Unimplemented:** Read as '0'
- bit 4 **EEIF:** Data EEPROM/FLASH Write Operation Interrupt Flag bit
 1 = The write operation is complete (must be cleared in software)
 0 = The write operation is not complete, or has not been started
- bit 3 **Unimplemented:** Read as '0'
- bit 2 **LVDIF:** Low Voltage Detect Interrupt Flag bit
 1 = A low voltage condition occurred (must be cleared in software)
 0 = The device voltage is above the Low Voltage Detect trip point
- bit 1 **TMR3IF:** TMR3 Overflow Interrupt Flag bit
 1 = TMR3 register overflowed (must be cleared in software)
 0 = TMR3 register did not overflow
- bit 0 **Unimplemented:** Read as '0'

Legend:			
R = Readable bit	W = Writable bit	U = Unimplemented bit, read as '0'	
- n = Value at POR	'1' = Bit is set	'0' = Bit is cleared	x = Bit is unknown

PIC18F1220/1320

9.3 PIE Registers

The PIE registers contain the individual enable bits for the peripheral interrupts. Due to the number of peripheral interrupt sources, there are two Peripheral Interrupt Enable Registers (PIE1, PIE2). When IPEN = 0, the PEIE bit must be set to enable any of these peripheral interrupts.

REGISTER 9-6: PIE1: PERIPHERAL INTERRUPT ENABLE REGISTER 1

U-0	R/W-0	R/W-0	R/W-0	U-0	R/W-0	R/W-0	R/W-0
—	ADIE	RCIE	TXIE	—	CCP1IE	TMR2IE	TMR1IE
bit 7				bit 0			

- bit 7 **Unimplemented:** Read as '0'
- bit 6 **ADIE:** A/D Converter Interrupt Enable bit
1 = Enables the A/D interrupt
0 = Disables the A/D interrupt
- bit 5 **RCIE:** USART Receive Interrupt Enable bit
1 = Enables the USART receive interrupt
0 = Disables the USART receive interrupt
- bit 4 **TXIE:** USART Transmit Interrupt Enable bit
1 = Enables the USART transmit interrupt
0 = Disables the USART transmit interrupt
- bit 3 **Unimplemented:** Read as '0'
- bit 2 **CCP1IE:** CCP1 Interrupt Enable bit
1 = Enables the CCP1 interrupt
0 = Disables the CCP1 interrupt
- bit 1 **TMR2IE:** TMR2 to PR2 Match Interrupt Enable bit
1 = Enables the TMR2 to PR2 match interrupt
0 = Disables the TMR2 to PR2 match interrupt
- bit 0 **TMR1IE:** TMR1 Overflow Interrupt Enable bit
1 = Enables the TMR1 overflow interrupt
0 = Disables the TMR1 overflow interrupt

Legend:			
R = Readable bit	W = Writable bit	U = Unimplemented bit, read as '0'	
- n = Value at POR	'1' = Bit is set	'0' = Bit is cleared	x = Bit is unknown

REGISTER 9-7: PIE2: PERIPHERAL INTERRUPT ENABLE REGISTER 2

R/W-0	U-0	U-0	R/W-0	U-0	R/W-0	R/W-0	U-0	
OSCFIE	—	—	EEIE	—	LVDIE	TMR3IE	—	
bit 7								bit 0

- bit 7 **OSCFIE:** Oscillator Fail Interrupt Enable bit
1 = Enabled
0 = Disabled
- bit 6-5 **Unimplemented:** Read as '0'
- bit 4 **EEIE:** Data EEPROM/FLASH Write Operation Interrupt Enable bit
1 = Enabled
0 = Disabled
- bit 3 **Unimplemented:** Read as '0'
- bit 2 **LVDIE:** Low Voltage Detect Interrupt Enable bit
1 = Enabled
0 = Disabled
- bit 1 **TMR3IE:** TMR3 Overflow Interrupt Enable bit
1 = Enabled
0 = Disabled
- bit 0 **Unimplemented:** Read as '0'

Legend:			
R = Readable bit	W = Writable bit	U = Unimplemented bit, read as '0'	
- n = Value at POR	'1' = Bit is set	'0' = Bit is cleared	x = Bit is unknown

PIC18F1220/1320

9.4 IPR Registers

The IPR registers contain the individual priority bits for the peripheral interrupts. Due to the number of peripheral interrupt sources, there are two peripheral Interrupt Priority Registers (IPR1, IPR2). Using the priority bits requires that the Interrupt Priority Enable (IPEN) bit be set.

REGISTER 9-8: IPR1: PERIPHERAL INTERRUPT PRIORITY REGISTER 1

U-0	R/W-1	R/W-1	R/W-1	U-0	R/W-1	R/W-1	R/W-1
—	ADIP	RCIP	TXIP	—	CCP1IP	TMR2IP	TMR1IP
bit 7							bit 0

- bit 7 **Unimplemented:** Read as '0'
- bit 6 **ADIP:** A/D Converter Interrupt Priority bit
1 = High priority
0 = Low priority
- bit 5 **RCIP:** USART Receive Interrupt Priority bit
1 = High priority
0 = Low priority
- bit 4 **TXIP:** USART Transmit Interrupt Priority bit
1 = High priority
0 = Low priority
- bit 3 **Unimplemented:** Read as '0'
- bit 2 **CCP1IP:** CCP1 Interrupt Priority bit
1 = High priority
0 = Low priority
- bit 1 **TMR2IP:** TMR2 to PR2 Match Interrupt Priority bit
1 = High priority
0 = Low priority
- bit 0 **TMR1IP:** TMR1 Overflow Interrupt Priority bit
1 = High priority
0 = Low priority

Legend:

R = Readable bit	W = Writable bit	U = Unimplemented bit, read as '0'
- n = Value at POR	'1' = Bit is set	'0' = Bit is cleared x = Bit is unknown

REGISTER 9-9: IPR2: PERIPHERAL INTERRUPT PRIORITY REGISTER 2

R/W-1	U-0	U-0	R/W-1	U-0	R/W-1	R/W-1	U-0
OSCFIP	—	—	EEIP	—	LVDIP	TMR3IP	—
bit 7						bit 0	

- bit 7 **OSCFIP:** Oscillator Fail Interrupt Priority bit
1 = High priority
0 = Low priority
- bit 6-5 **Unimplemented:** Read as '0'
- bit 4 **EEIP:** Data EEPROM/FLASH Write Operation Interrupt Priority bit
1 = High priority
0 = Low priority
- bit 3 **Unimplemented:** Read as '0'
- bit 2 **LVDIP:** Low Voltage Detect Interrupt Priority bit
1 = High priority
0 = Low priority
- bit 1 **TMR3IP:** TMR3 Overflow Interrupt Priority bit
1 = High priority
0 = Low priority
- bit 0 **Unimplemented:** Read as '0'

Legend:			
R = Readable bit	W = Writable bit	U = Unimplemented bit, read as '0'	
- n = Value at POR	'1' = Bit is set	'0' = Bit is cleared	x = Bit is unknown

PIC18F1220/1320

9.5 RCON Register

The RCON register contains bits used to determine the cause of the last RESET or wake-up from Low Power mode. RCON also contains the bit that enables interrupt priorities (IPEN).

REGISTER 9-10: RCON REGISTER

R/W-0	U-0	U-0	R/W-1	R-1	R-1	R/W-0	R/W-0
IPEN	—	—	$\overline{\text{RI}}$	$\overline{\text{TO}}$	$\overline{\text{PD}}$	$\overline{\text{POR}}$	$\overline{\text{BOR}}$
bit 7							bit 0

- bit 7 **IPEN:** Interrupt Priority Enable bit
1 = Enable priority levels on interrupts
0 = Disable priority levels on interrupts (PIC16CXXX Compatibility mode)
- bit 6-5 **Unimplemented:** Read as '0'
- bit 4 **$\overline{\text{RI}}$:** RESET Instruction Flag bit
For details of bit operation, see Register 5-3
- bit 3 **$\overline{\text{TO}}$:** Watchdog Time-out Flag bit
For details of bit operation, see Register 5-3
- bit 2 **$\overline{\text{PD}}$:** Power-down Detection Flag bit
For details of bit operation, see Register 5-3
- bit 1 **$\overline{\text{POR}}$:** Power-on Reset Status bit
For details of bit operation, see Register 5-3
- bit 0 **$\overline{\text{BOR}}$:** Brown-out Reset Status bit
For details of bit operation, see Register 5-3

Legend:

R = Readable bit	W = Writable bit	U = Unimplemented bit, read as '0'
- n = Value at POR	'1' = Bit is set	'0' = Bit is cleared x = Bit is unknown

9.6 INTn Pin Interrupts

External interrupts on the RB0/INT0, RB1/INT1 and RB2/INT2 pins are edge triggered: either rising, if the corresponding INTEDGx bit is set in the INTCON2 register, or falling, if the INTEDGx bit is clear. When a valid edge appears on the RBx/INTx pin, the corresponding flag bit INTxF is set. This interrupt can be disabled by clearing the corresponding enable bit INTxE. Flag bit INTxF must be cleared in software in the Interrupt Service Routine before re-enabling the interrupt. All external interrupts (INT0, INT1 and INT2) can wake-up the processor from Low Power modes, if bit INTxE was set prior to going into Low Power modes. If the global interrupt enable bit GIE is set, the processor will branch to the interrupt vector following wake-up.

Interrupt priority for INT1 and INT2 is determined by the value contained in the interrupt priority bits, INT1IP (INTCON3<6>) and INT2IP (INTCON3<7>). There is no priority bit associated with INT0. It is always a high priority interrupt source.

9.7 TMR0 Interrupt

In 8-bit mode (which is the default), an overflow (FFh → 00h) in the TMR0 register will set flag bit TMR0IF. In 16-bit mode, an overflow (FFFFh → 0000h) in the TMR0H:TMR0L registers will set flag bit TMR0IF. The interrupt can be enabled/disabled by setting/clearing enable bit TMR0IE (INTCON<5>). Interrupt priority for Timer0 is determined by the value contained in the interrupt priority bit TMR0IP (INTCON2<2>). See Section 11.0 for further details on the Timer0 module.

9.8 PORTB Interrupt-on-Change

An input change on PORTB<7:4> sets flag bit RBIF (INTCON<0>). The interrupt can be enabled/disabled by setting/clearing enable bit, RBIE (INTCON<3>). Interrupt priority for PORTB interrupt-on-change is determined by the value contained in the interrupt priority bit, RBIP (INTCON2<0>).

9.9 Context Saving During Interrupts

During interrupts, the return PC address is saved on the stack. Additionally, the WREG, STATUS and BSR registers are saved on the fast return stack. If a fast return from interrupt is not used (see Section 5.3), the user may need to save the WREG, STATUS and BSR registers on entry to the Interrupt Service Routine. Depending on the user's application, other registers may also need to be saved. Example 9-1 saves and restores the WREG, STATUS and BSR registers during an Interrupt Service Routine.

EXAMPLE 9-1: SAVING STATUS, WREG AND BSR REGISTERS IN RAM

```

MOVWF  W_TEMP                ; W_TEMP is in virtual bank
MOVFF  STATUS, STATUS_TEMP   ; STATUS_TEMP located anywhere
MOVFF  BSR,    BSR_TEMP      ; BSR_TEMP located anywhere
;
; USER ISR CODE
;
MOVFF  BSR_TEMP,  BSR        ; Restore BSR
MOVF   W_TEMP,   W          ; Restore WREG
MOVFF  STATUS_TEMP, STATUS   ; Restore STATUS
    
```

PIC18F1220/1320

NOTES:

10.0 I/O PORTS

Depending on the device selected and features enabled, there are up to five ports available. Some pins of the I/O ports are multiplexed with an alternate function from the peripheral features on the device. In general, when a peripheral is enabled, that pin may not be used as a general purpose I/O pin.

Each port has three registers for its operation. These registers are:

- TRIS register (data direction register)
- PORT register (reads the levels on the pins of the device)
- LAT register (output latch)

The data latch (LAT register) is useful for read-modify-write operations on the value that the I/O pins are driving.

A simplified model of a generic I/O port without the interfaces to other peripherals is shown in Figure 10-1.

FIGURE 10-1: GENERIC I/O PORT OPERATION

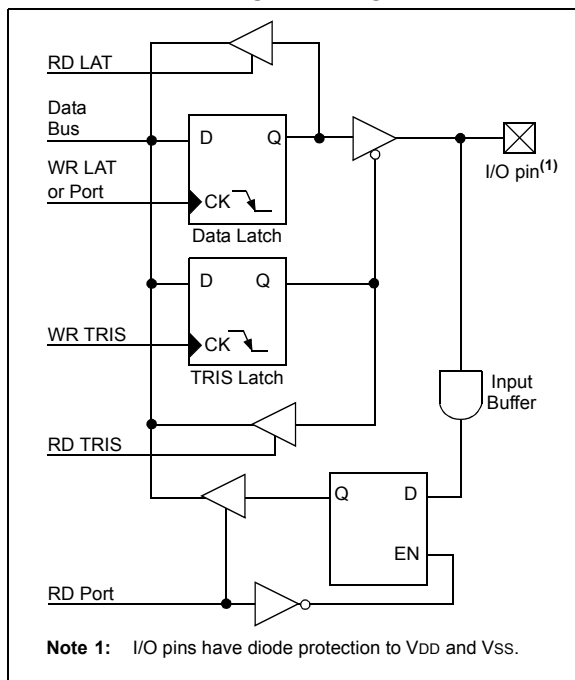

10.1 PORTA, TRISA and LATA Registers

PORTA is a 8-bit wide, bi-directional port. The corresponding Data Direction register is TRISA. Setting a TRISA bit (= 1) will make the corresponding PORTA pin an input (i.e., put the corresponding output driver in a High-Impedance mode). Clearing a TRISA bit (= 0) will make the corresponding PORTA pin an output (i.e., put the contents of the output latch on the selected pin).

Reading the PORTA register reads the status of the pins, whereas writing to it will write to the port latch.

The Data Latch register (LATA) is also memory mapped. Read-modify-write operations on the LATA register reads and writes the latched output value for PORTA.

The RA4 pin is multiplexed with the Timer0 module clock input and one of the comparator outputs to become the RA4/T0CKI/C1OUT pin.

The fourth pin of PORTA (RA5/MCLR/VPP) is an input only pin. Its operation is controlled by the MCLRE configuration bit in Configuration Register 3H (CONFIG3H<7>). When selected as a port pin (MCLRE = 0), it functions as a digital input only pin; as such, it does not have TRIS or LAT bits associated with its operation. Otherwise, it functions as the device's Master Clear input. In either configuration, RA5 also functions as the programming voltage input during programming.

Note: On a Power-on Reset, RA5 is enabled as a digital input only if Master Clear functionality is disabled.

Pins RA6 and RA7 are multiplexed with the main oscillator pins; they are enabled as oscillator or I/O pins by the selection of the main oscillator in Configuration Register 1H (see Section 19.1 for details). When they are not used as port pins, RA6 and RA7 and their associated TRIS and LAT bits are read as '0'.

The other PORTA pins are multiplexed with analog inputs, the analog VREF+ and VREF- inputs and the LVD input. The operation of pins RA3:RA0 as A/D converter inputs is selected by clearing/setting the control bits in the ADCON1 register (A/D Control Register1).

Note: On a Power-on Reset, RA3:RA0 are configured as analog inputs and read as '0'. RA4 is configured as a digital input.

The RA4/T0CKI/C1OUT pin is a Schmitt Trigger input and an open drain output. All other PORTA pins have TTL input levels and full CMOS output drivers.

The TRISA register controls the direction of the RA pins, even when they are being used as analog inputs. The user must ensure the bits in the TRISA register are maintained set when using them as analog inputs.

EXAMPLE 10-1: INITIALIZING PORTA

```

CLRFB PORTA      ; Initialize PORTA by
                  ; clearing output
                  ; data latches
CLRFB LATA       ; Alternate method
                  ; to clear output
                  ; data latches
MOVLW 0x7F      ; Configure A/D
MOVWF ADCON1    ; for digital inputs
MOVLW 0xD0      ; Value used to
                  ; initialize data
                  ; direction
MOVWF TRISA     ; Set RA<3:0> as outputs
                  ; RA<7:4> as inputs
    
```

PIC18F1220/1320

FIGURE 10-2: BLOCK DIAGRAM OF RA3:RA0 PINS

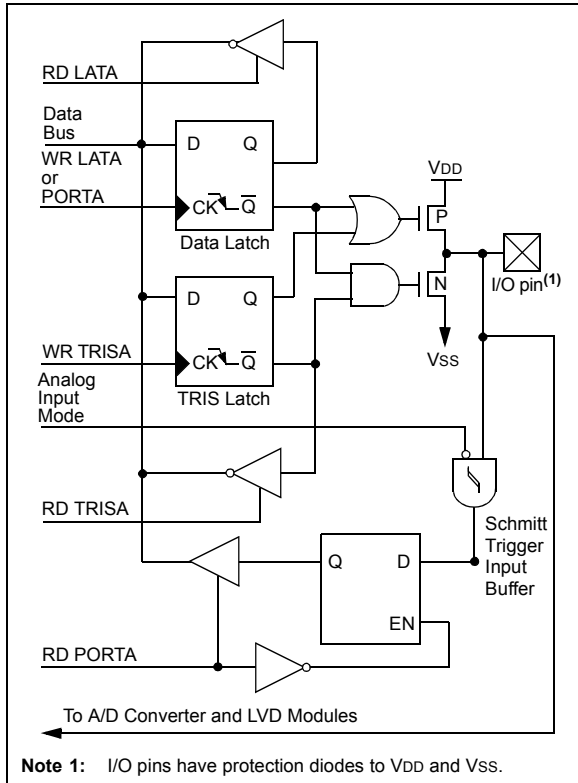

FIGURE 10-4: BLOCK DIAGRAM OF RA4/T0CKI PIN

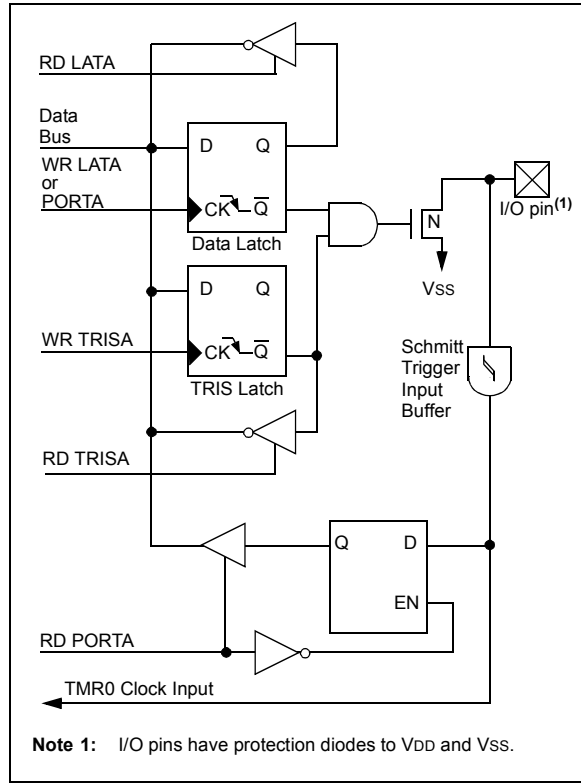

FIGURE 10-3: BLOCK DIAGRAM OF OSC2/CLKO/RA6 PIN

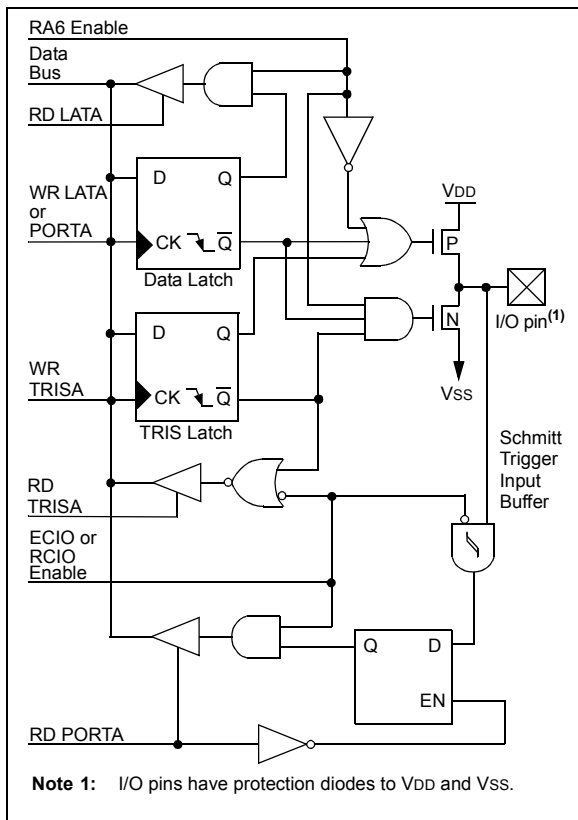

FIGURE 10-5: BLOCK DIAGRAM OF OSC1/CLKI/RA7 PIN

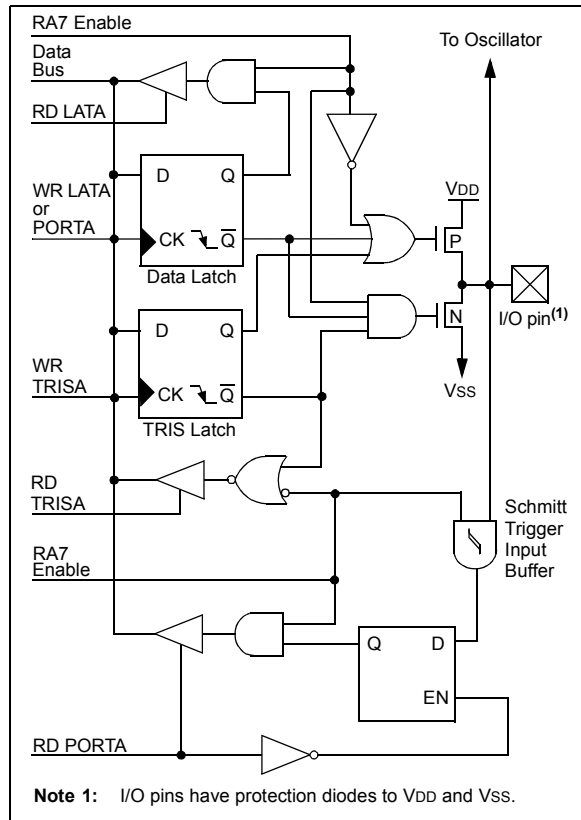

FIGURE 10-6: MCLR/RA5 PIN BLOCK DIAGRAM

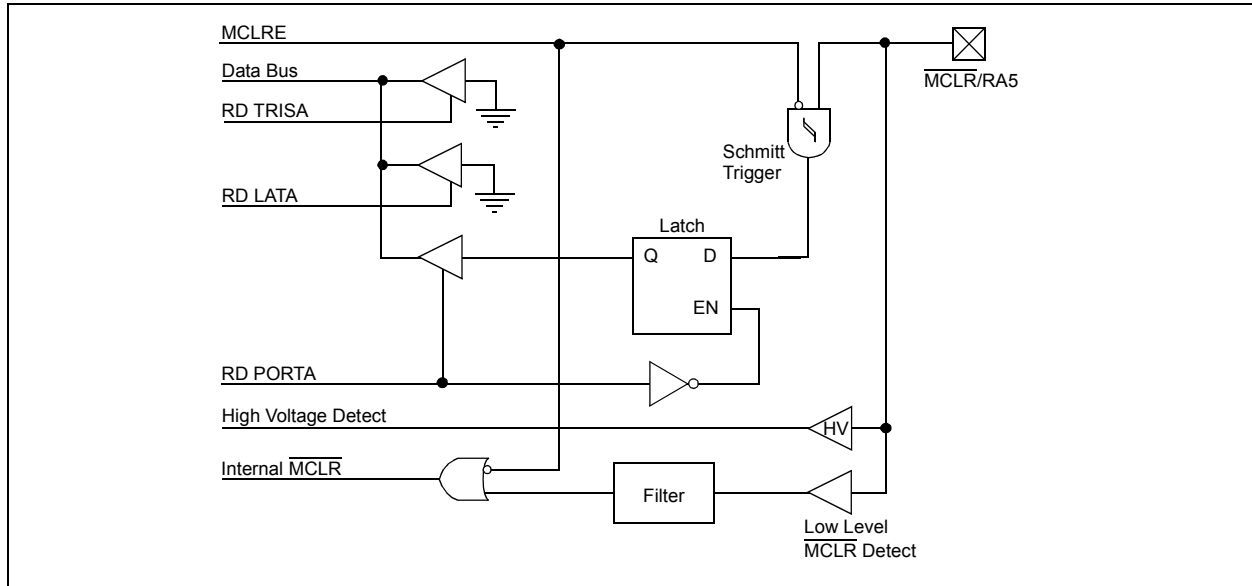

TABLE 10-1: PORTA FUNCTIONS

Name	Bit#	Buffer	Function
RA0/AN0	bit0	ST	Input/output or analog input.
RA1/AN1/LVDIN	bit1	ST	Input/output or analog input.
RA2/AN2/VREF-	bit2	ST	Input/output, analog input or VREF-.
RA3/AN3/VREF+	bit3	ST	Input/output, analog input or VREF+.
RA4/T0CKI	bit4	ST	Input/output, external clock input for Timer0. Output is open drain type.
MCLR/VPP/RA5	bit5	ST	Master Clear input or programming voltage input (if MCLR is enabled); input only port pin or programming voltage input (if MCLR is disabled).
OSC2/CLKO/RA6	bit6	ST	OSC2, clock output or I/O pin.
OSC1/CLKI/RA7	bit7	ST	OSC1, clock input or I/O pin.

Legend: TTL = TTL input, ST = Schmitt Trigger input

TABLE 10-2: SUMMARY OF REGISTERS ASSOCIATED WITH PORTA

Name	Bit 7	Bit 6	Bit 5	Bit 4	Bit 3	Bit 2	Bit 1	Bit 0	Value on POR, BOR	Value on all other RESETS
PORTA	RA7 ⁽¹⁾	RA6 ⁽¹⁾	RA5 ⁽²⁾	RA4	RA3	RA2	RA1	RA0	xx0x 0000	uu0u 0000
LATA	LATA7 ⁽¹⁾	LATA6 ⁽¹⁾	—	LATA Data Output Register					xx-x xxxx	uu-u uuuu
TRISA	TRISA7 ⁽¹⁾	TRISA6 ⁽¹⁾	—	PORTA Data Direction Register					11-1 1111	11-1 1111
ADCON1	—	PCFG6	PCFG5	PCFG4	PCFG3	PCFG2	PCFG1	PCFG0	-000 0000	-000 0000

Legend: x = unknown, u = unchanged, - = unimplemented locations read as '0'. Shaded cells are not used by PORTA.

Note 1: RA7:RA6 and their associated latch and data direction bits are enabled as I/O pins based on oscillator configuration; otherwise, they are read as '0'.

2: RA5 is an input only if MCLR is enabled or disabled.

PIC18F1220/1320

10.2 PORTB, TRISB and LATB Registers

PORTB is an 8-bit wide, bi-directional port. The corresponding Data Direction register is TRISB. Setting a TRISB bit (= 1) will make the corresponding PORTB pin an input (i.e., put the corresponding output driver in a High-Impedance mode). Clearing a TRISB bit (= 0) will make the corresponding PORTB pin an output (i.e., put the contents of the output latch on the selected pin).

The Data Latch register (LATB) is also memory mapped. Read-modify-write operations on the LATB register reads and writes the latched output value for PORTB.

EXAMPLE 10-2: INITIALIZING PORTB

```

CLRF  PORTB  ; Initialize PORTB by
             ; clearing output
             ; data latches

CLRF  LATB   ; Alternate method
             ; to clear output
             ; data latches

MOVLW 0x70  ; Set RB0, RB1, RB4 as
MOVWF  ADCON1 ; digital I/O pins
MOVLW 0xCF  ; Value used to
             ; initialize data
             ; direction

MOVWF  TRISB ; Set RB<3:0> as inputs
             ; RB<5:4> as outputs
             ; RB<7:6> as inputs
    
```

Pins RB0 - RB2 are multiplexed with INT0 - INT2; pins RB0, RB1, and RB4 are multiplexed with A/D inputs; pins RB1 and RB4 are multiplexed with USART; and pins RB2, RB3, RB6, and RB7 are multiplexed with ECCP.

Each of the PORTB pins has a weak internal pull-up. A single control bit can turn on all the pull-ups. This is performed by clearing bit $\overline{\text{RBPU}}$ (INTCON2<7>). The weak pull-up is automatically turned off when the port pin is configured as an output. The pull-ups are disabled on a Power-on Reset.

Note: On a Power-on Reset, RB4:RB0 are configured as analog inputs by default, and read as '0'; RB7:RB5 are configured as digital inputs.

Four of the PORTB pins (RB7:RB4) have an interrupt-on-change feature. Only pins configured as inputs can cause this interrupt to occur (i.e., any RB7:RB4 pin configured as an output is excluded from the interrupt-on-change comparison). The input pins (of RB7:RB4) are compared with the old value latched on the last read of PORTB. The "mismatch" outputs of RB7:RB4 are ORed together to generate the RB Port Change Interrupt with flag bit, RBIF (INTCON<0>).

This interrupt can wake the device from SLEEP. The user, in the Interrupt Service Routine, can clear the interrupt in the following manner:

- a) Any read or write of PORTB (except with the MOVFF instruction). This will end the mismatch condition.
- b) Clear flag bit RBIF.

A mismatch condition will continue to set flag bit RBIF. Reading PORTB will end the mismatch condition and allow flag bit RBIF to be cleared.

The interrupt-on-change feature is recommended for wake-up on key depression operation and operations where PORTB is only used for the interrupt-on-change feature. Polling of PORTB is not recommended while using the interrupt-on-change feature.

FIGURE 10-7: BLOCK DIAGRAM OF RB0/AN4/INT0 PIN

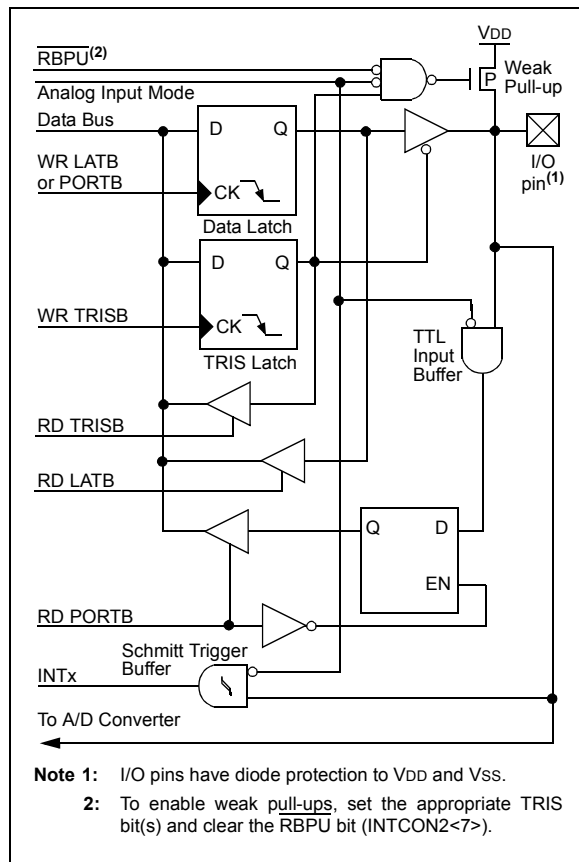
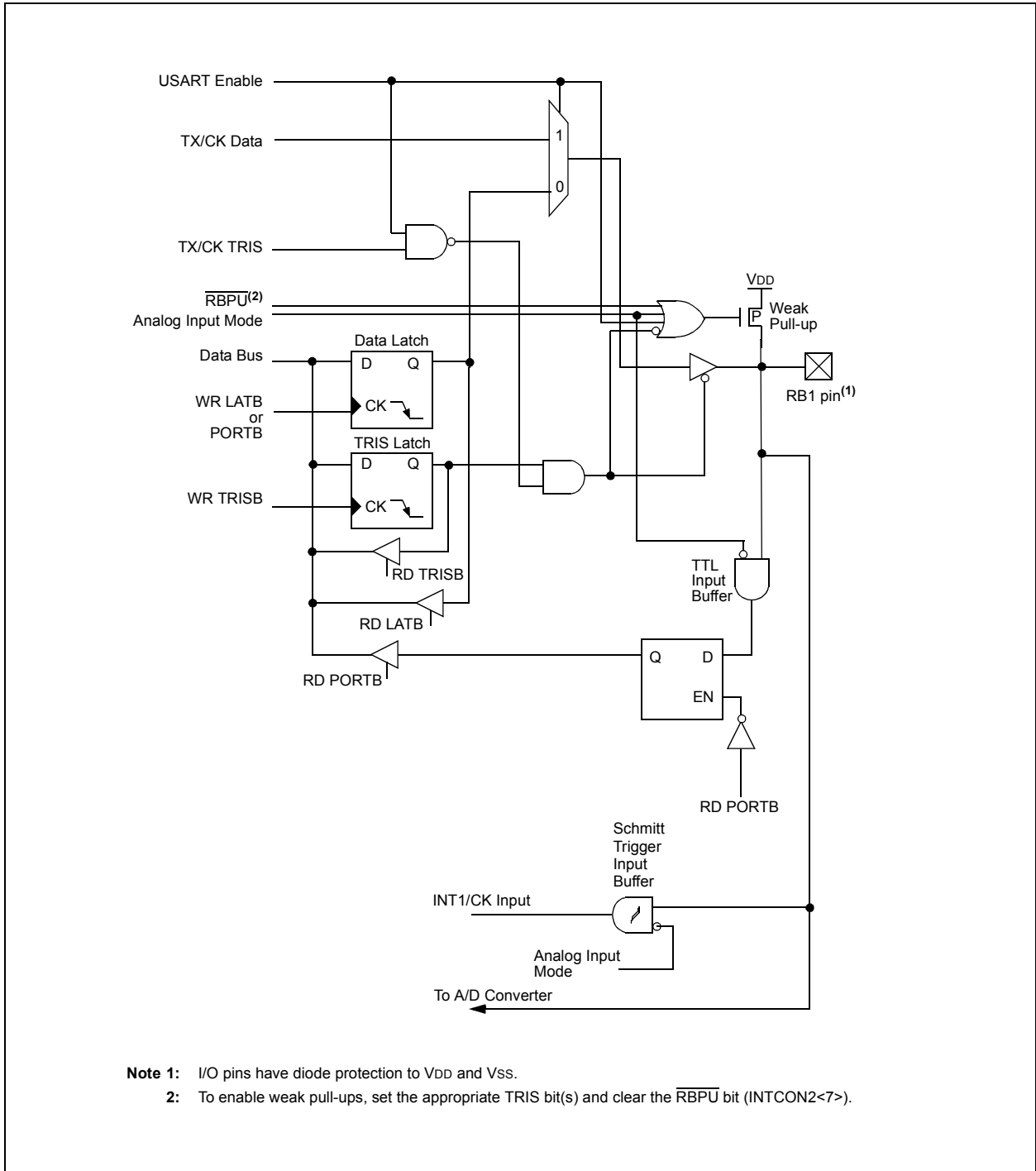

FIGURE 10-8: BLOCK DIAGRAM OF RB1/AN5/TX/CK/INT1 PIN



PIC18F1220/1320

FIGURE 10-9: BLOCK DIAGRAM OF RB2/P1B/INT2 PIN

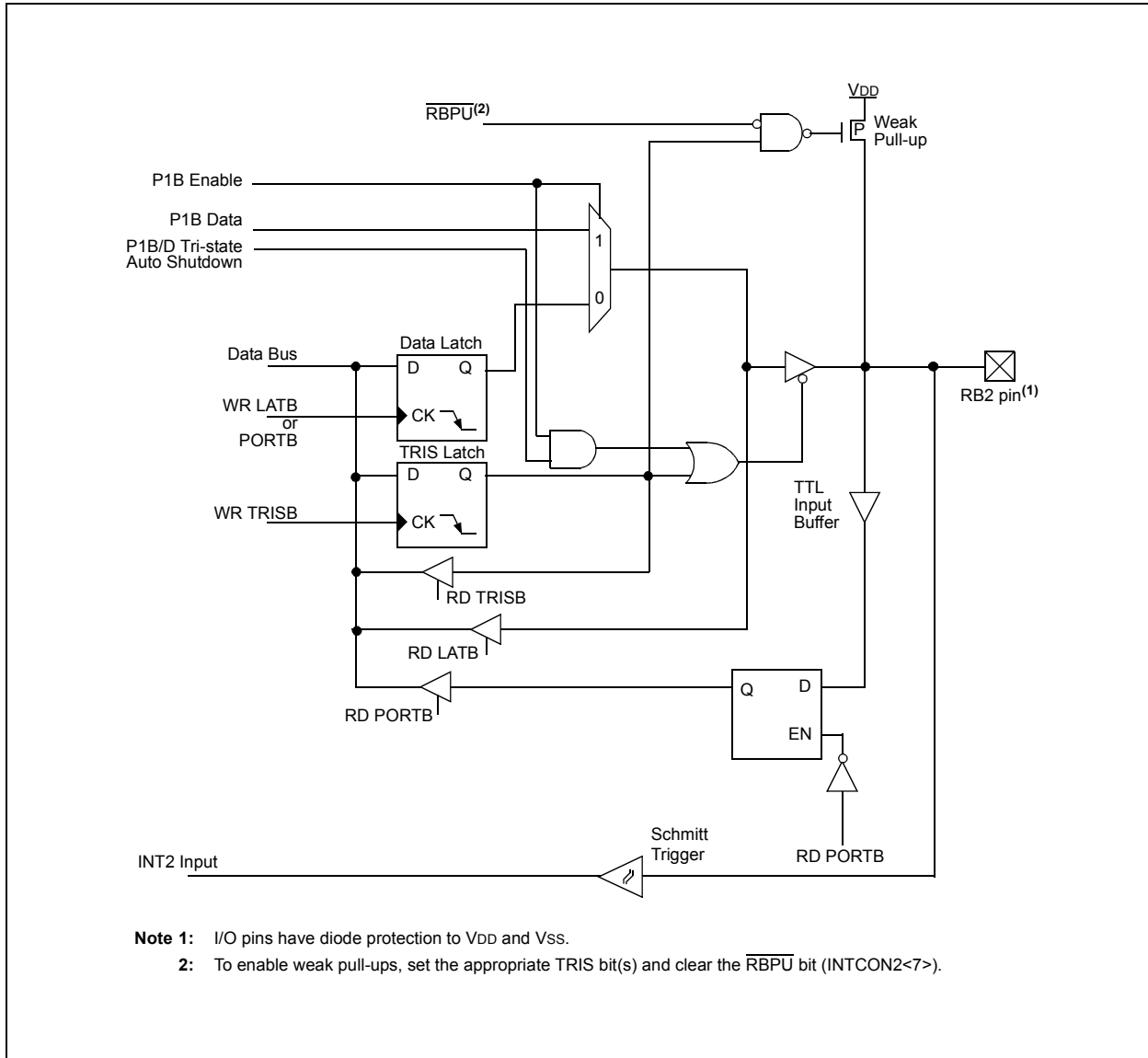
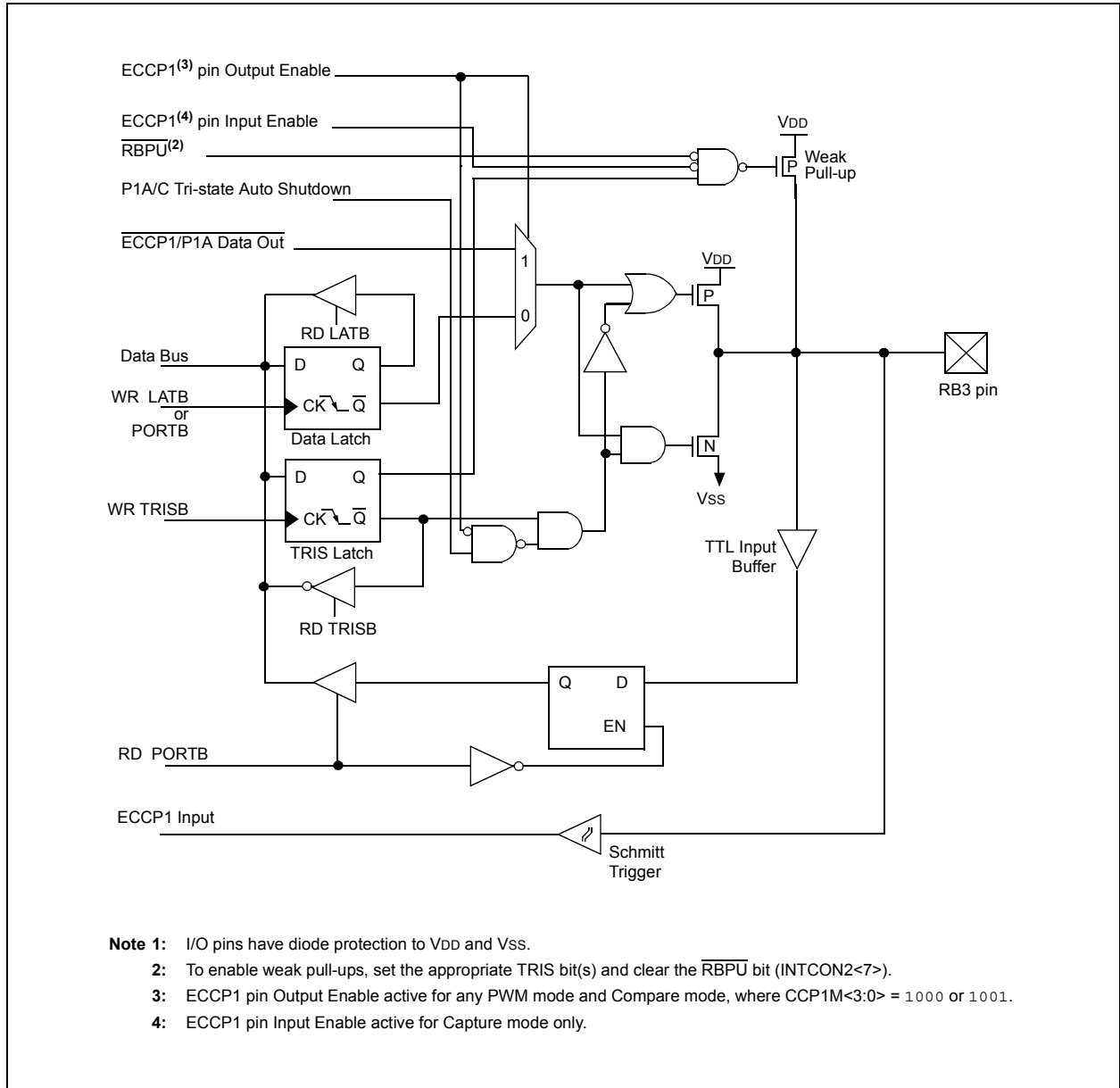

FIGURE 10-10: BLOCK DIAGRAM OF RB3/CCP1/P1A PIN



PIC18F1220/1320

FIGURE 10-11: BLOCK DIAGRAM OF RB4/AN6/RX/DT/KBI0 PIN

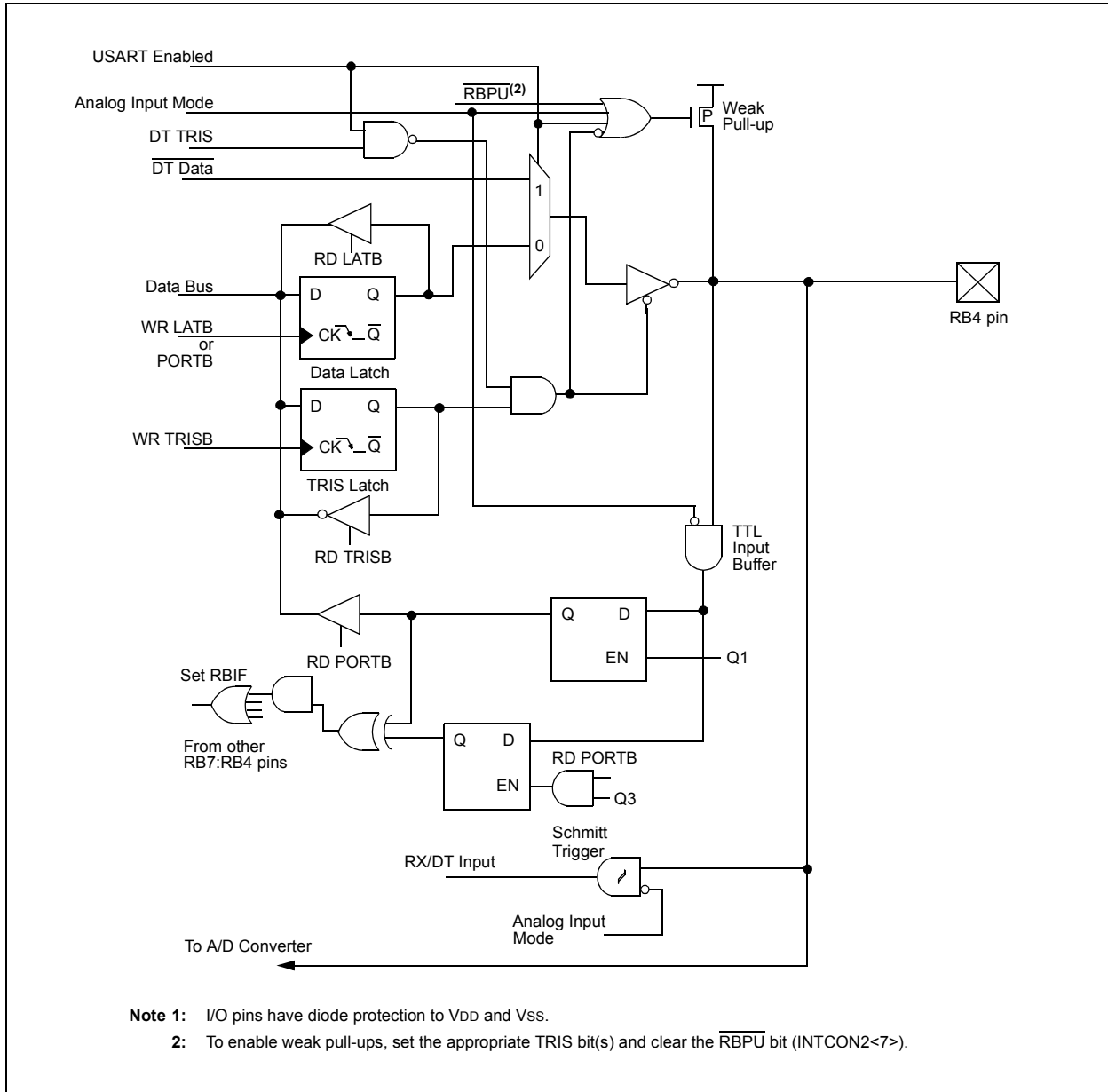
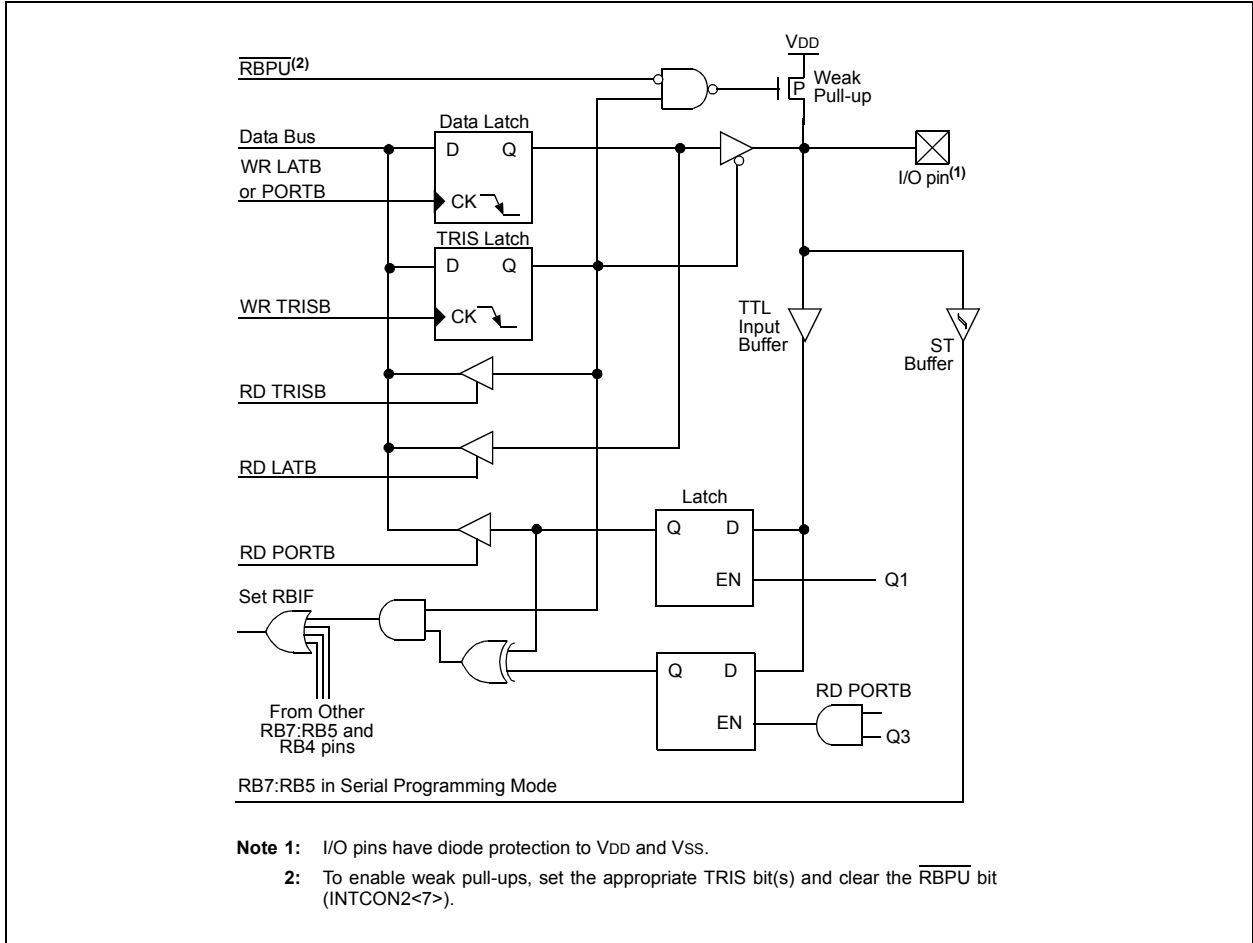

FIGURE 10-12: BLOCK DIAGRAM OF RB5/PGM/KB1 PIN



PIC18F1220/1320

FIGURE 10-13: BLOCK DIAGRAM OF RB6/PGC/T1OSO/T1CKI/P1C/KBI2 PIN

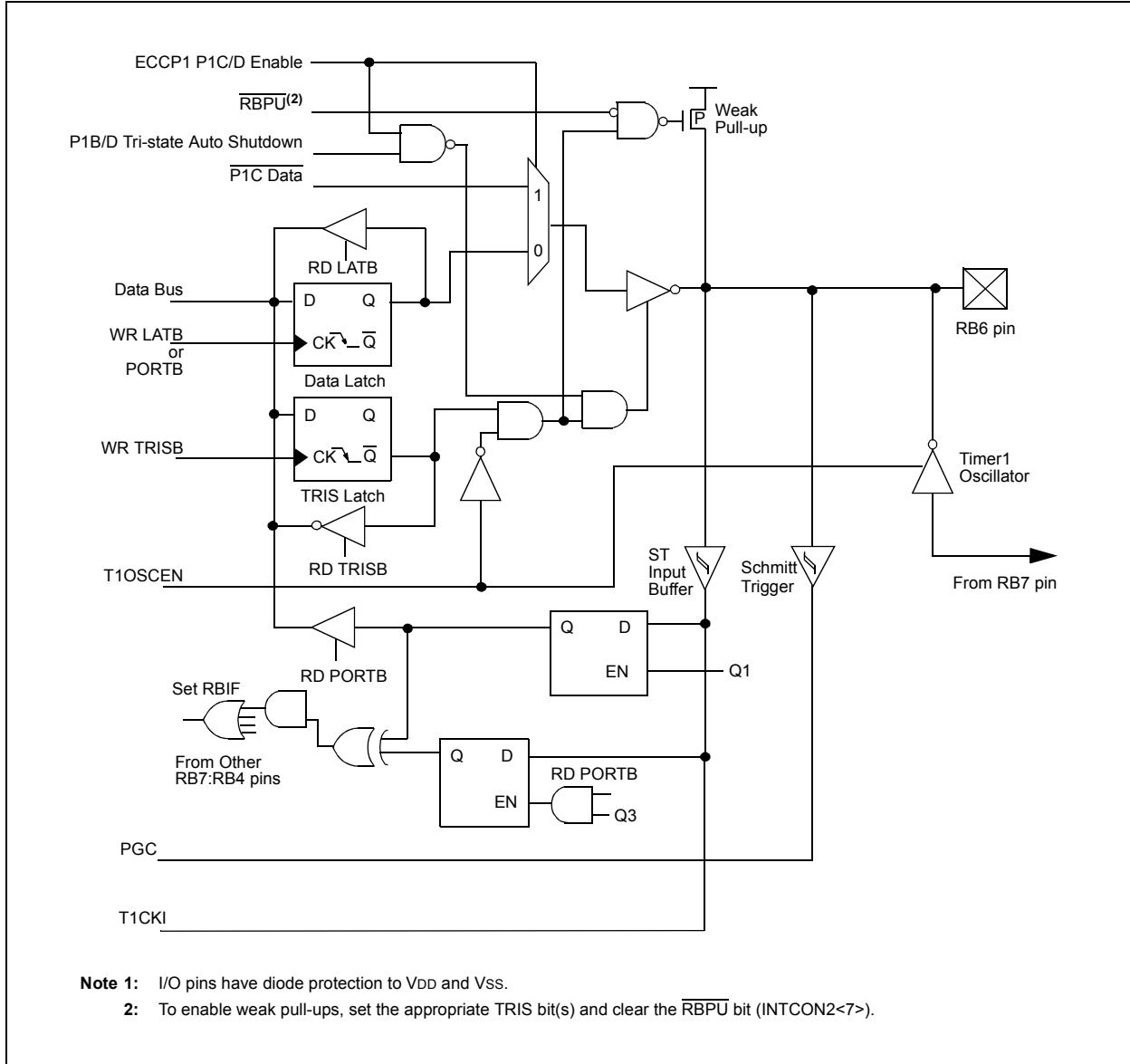
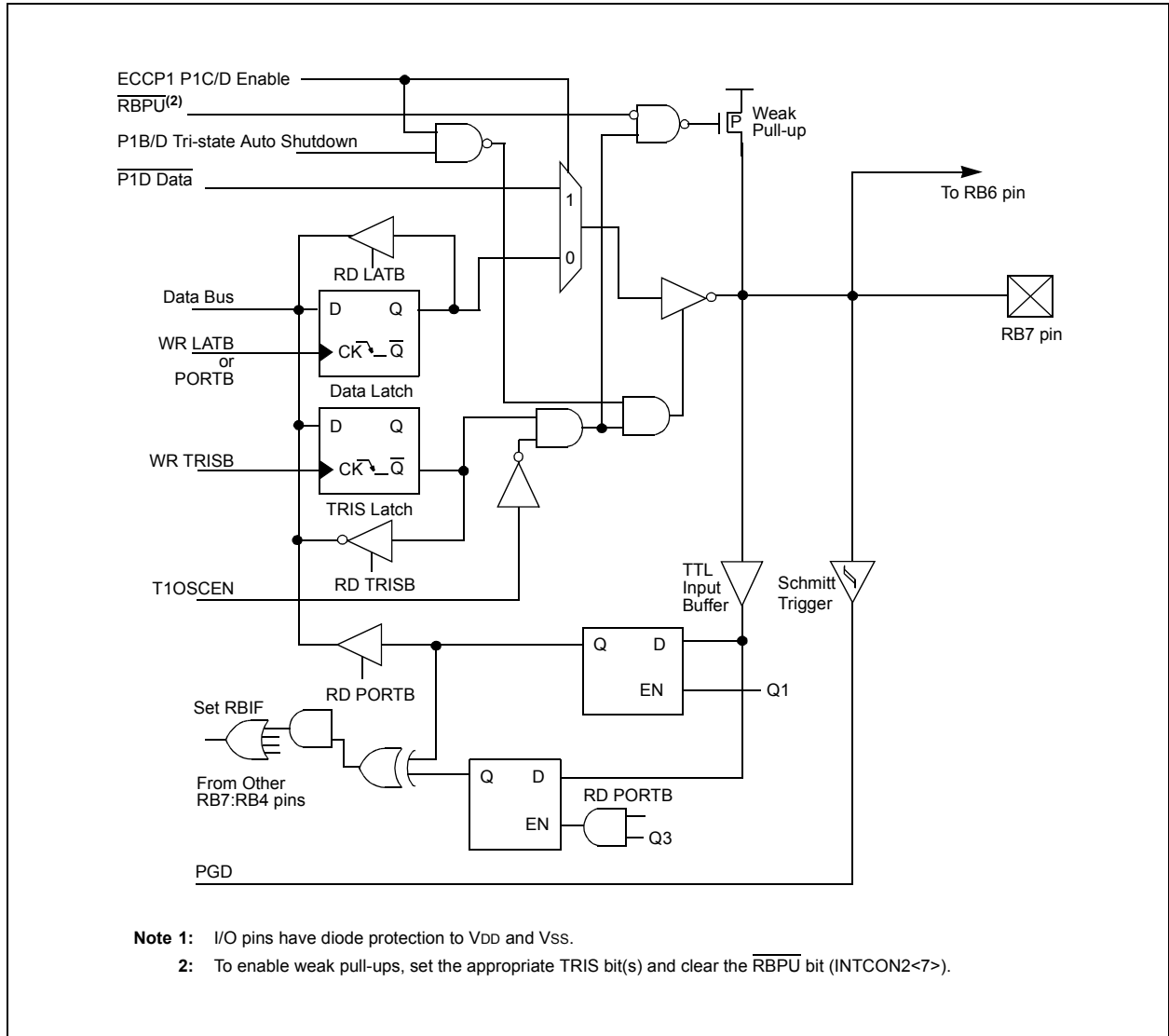

FIGURE 10-14: BLOCK DIAGRAM OF RB7/PGD/T1OSI/P1D/KBI3 PIN



PIC18F1220/1320

TABLE 10-3: PORTB FUNCTIONS

Name	Bit#	Buffer	Function
RB0/AN4/INT0	bit0	TTL ⁽¹⁾ /ST ⁽²⁾	Input/output port pin or Timer1 oscillator output/Timer1 clock input.
RB1/AN5/TX/CK/INT1	bit1	TTL ⁽¹⁾ /ST ⁽²⁾	Input/output port pin, Enhanced USART Asynchronous Transmit, or Addressable USART Synchronous Clock.
RB2/P1B/INT2	bit2	TTL ⁽¹⁾ /ST ⁽²⁾	Input/output pin, external interrupt input2 or analog input. Internal software programmable weak pull-up.
RB3/CCP1/P1A	bit3	TTL ⁽¹⁾ /ST ⁽³⁾	Input/output pin or analog input. Capture1 input/Compare1 output/PWM output. Internal software programmable weak pull-up.
RB4/AN6/RX/DT	bit4	TTL/ST ⁽⁴⁾	Input/output port pin, Enhanced USART Asynchronous Receive, or Addressable USART Synchronous Data.
RB5/PGM	bit5	TTL/ST ⁽⁵⁾	Input/output pin (with interrupt-on-change). Internal software programmable weak pull-up. Low voltage ICSP enable pin.
RB6/PGC/T1OSO/T1CKI/P1C	bit6	TTL/ST ⁽⁵⁾	Input/output pin (with interrupt-on-change). Internal software programmable weak pull-up. Serial programming clock.
RB7/PGD/T1OSI/P1D	bit7	TTL/ST ⁽⁵⁾	Input/output pin (with interrupt-on-change) Timer1 oscillator input. Internal software programmable weak pull-up. Serial programming data.

Legend: TTL = TTL input, ST = Schmitt Trigger input

Note 1: This buffer is a TTL input when configured as an analog input.

2: This buffer is a Schmitt Trigger input when configured as the external interrupt.

3: This buffer is a Schmitt Trigger input when configured as the CCP2 input.

4: This buffer is a Schmitt Trigger input when used as USART receive input.

5: This buffer is a Schmitt Trigger input when used in Serial Programming mode.

TABLE 10-4: SUMMARY OF REGISTERS ASSOCIATED WITH PORTB

Name	Bit 7	Bit 6	Bit 5	Bit 4	Bit 3	Bit 2	Bit 1	Bit 0	Value on POR, BOR	Value on all other RESETS
PORTB	RB7	RB6	RB5	RB4	RB3	RB2	RB1	RB0	xxxq qqqq	uuuu uuuu
LATB	LATB Data Output Register								xxxx xxxx	uuuu uuuu
TRISB	PORTB Data Direction Register								1111 1111	1111 1111
INTCON	GIE/GIEH	PEIE/GIEL	TMR0IE	INT0IE	RBIE	TMR0IF	INT0IF	RBIF	0000 000x	0000 000u
INTCON2	RBPÜ	INTEDG0	INTEDG1	INTEDG2	—	TMR0IP	—	RBIP	1111 -1-1	1111 -1-1
INTCON3	INT2IP	INT1IP	—	INT2IE	INT1IE	—	INT2IF	INT1IF	11-0 0-00	11-0 0-00
ADCON1	—	PCFG6	PCFG5	PCFG4	PCFG3	PCFG2	PCFG1	PCFG0	-000 0000	-000 0000

Legend: x = unknown, u = unchanged, q = value depends on condition. Shaded cells are not used by PORTB.

11.0 TIMER0 MODULE

The Timer0 module has the following features:

- Software selectable as an 8-bit or 16-bit timer/counter
- Readable and writable
- Dedicated 8-bit software programmable prescaler
- Clock source selectable to be external or internal
- Interrupt-on-overflow from FFh to 00h in 8-bit mode and FFFFh to 0000h in 16-bit mode
- Edge select for external clock

Figure 11-1 shows a simplified block diagram of the Timer0 module in 8-bit mode and Figure 11-2 shows a simplified block diagram of the Timer0 module in 16-bit mode.

The T0CON register (Register 11-1) is a readable and writable register that controls all the aspects of Timer0, including the prescale selection.

REGISTER 11-1: T0CON: TIMER0 CONTROL REGISTER

R/W-1	R/W-1	R/W-1	R/W-1	R/W-1	R/W-1	R/W-1	R/W-1
TMR0ON	T08BIT	T0CS	T0SE	PSA	T0PS2	T0PS1	T0PS0
bit 7							bit 0

- bit 7 **TMR0ON:** Timer0 On/Off Control bit
 1 = Enables Timer0
 0 = Stops Timer0
- bit 6 **T08BIT:** Timer0 8-bit/16-bit Control bit
 1 = Timer0 is configured as an 8-bit timer/counter
 0 = Timer0 is configured as a 16-bit timer/counter
- bit 5 **T0CS:** Timer0 Clock Source Select bit
 1 = Transition on T0CKI pin
 0 = Internal instruction cycle clock (CLKO)
- bit 4 **T0SE:** Timer0 Source Edge Select bit
 1 = Increment on high-to-low transition on T0CKI pin
 0 = Increment on low-to-high transition on T0CKI pin
- bit 3 **PSA:** Timer0 Prescaler Assignment bit
 1 = Timer0 prescaler is NOT assigned. Timer0 clock input bypasses prescaler.
 0 = Timer0 prescaler is assigned. Timer0 clock input comes from prescaler output.
- bit 2-0 **T0PS2:T0PS0:** Timer0 Prescaler Select bits
 111 =1:256 prescale value
 110 =1:128 prescale value
 101 =1:64 prescale value
 100 =1:32 prescale value
 011 =1:16 prescale value
 010 =1:8 prescale value
 001 =1:4 prescale value
 000 =1:2 prescale value

Legend:

R = Readable bit	W = Writable bit	U = Unimplemented bit, read as '0'
- n = Value at POR	'1' = Bit is set	'0' = Bit is cleared x = Bit is unknown

PIC18F1220/1320

FIGURE 11-1: TIMER0 BLOCK DIAGRAM IN 8-BIT MODE

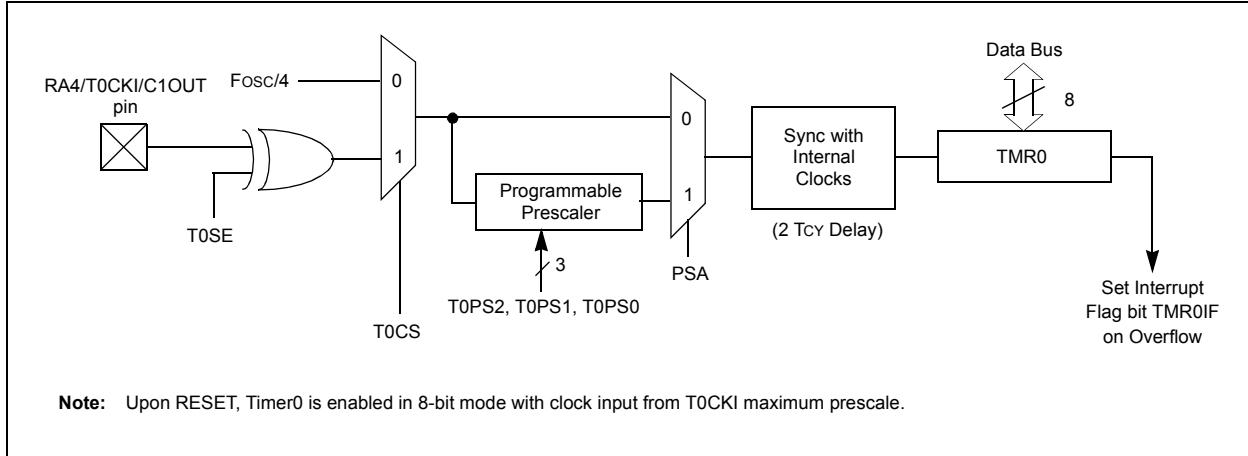
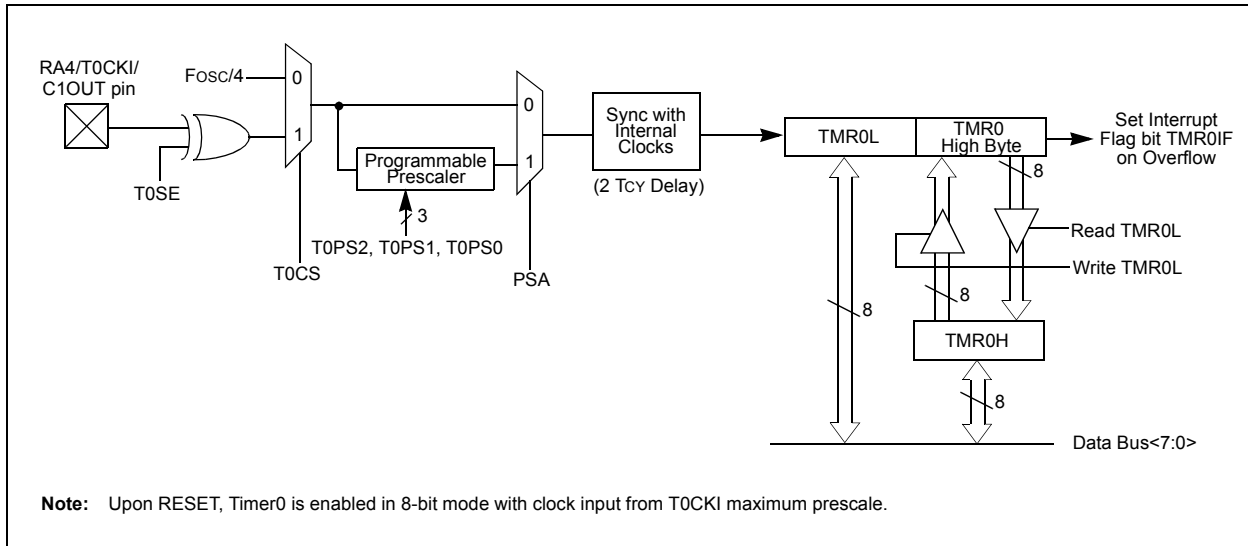

FIGURE 11-2: TIMER0 BLOCK DIAGRAM IN 16-BIT MODE



11.1 Timer0 Operation

Timer0 can operate as a timer or as a counter.

Timer mode is selected by clearing the T0CS bit. In Timer mode, the Timer0 module will increment every instruction cycle (without prescaler). If the TMR0 register is written, the increment is inhibited for the following two instruction cycles. The user can work around this by writing an adjusted value to the TMR0 register.

Counter mode is selected by setting the T0CS bit. In Counter mode, Timer0 will increment, either on every rising or falling edge of pin RA4/T0CKI. The incrementing edge is determined by the Timer0 Source Edge Select bit (T0SE). Clearing the T0SE bit selects the rising edge.

When an external clock input is used for Timer0, it must meet certain requirements. The requirements ensure the external clock can be synchronized with the internal phase clock (TOSC). Also, there is a delay in the actual incrementing of Timer0 after synchronization.

11.2 Prescaler

An 8-bit counter is available as a prescaler for the Timer0 module. The prescaler is not readable or writable.

The PSA and T0PS2:T0PS0 bits determine the prescaler assignment and prescale ratio.

Clearing bit PSA will assign the prescaler to the Timer0 module. When the prescaler is assigned to the Timer0 module, prescale values of 1:2, 1:4,..., 1:256 are selectable.

When assigned to the Timer0 module, all instructions writing to the TMR0 register (e.g., `CLRF TMR0`, `MOVWF TMR0`, `BSF TMR0`, `x....etc.`) will clear the prescaler count.

Note: Writing to TMR0 when the prescaler is assigned to Timer0 will clear the prescaler count, but will not change the prescaler assignment.

11.2.1 SWITCHING PRESCALER ASSIGNMENT

The prescaler assignment is fully under software control (i.e., it can be changed “on-the-fly” during program execution).

11.3 Timer0 Interrupt

The TMR0 interrupt is generated when the TMR0 register overflows from FFh to 00h in 8-bit mode, or FFFFh to 0000h in 16-bit mode. This overflow sets the TMR0IF bit. The interrupt can be masked by clearing the TMR0IE bit. The TMR0IE bit must be cleared in software by the Timer0 module Interrupt Service Routine before re-enabling this interrupt. The TMR0 interrupt cannot awaken the processor from Low Power SLEEP mode, since the timer requires clock cycles, even when T0CS is set.

11.4 16-Bit Mode Timer Reads and Writes

TMR0H is not the high byte of the timer/counter in 16-bit mode, but is actually a buffered version of the high byte of Timer0 (refer to Figure 11-2). The high byte of the Timer0 counter/timer is not directly readable nor writable. TMR0H is updated with the contents of the high byte of Timer0 during a read of TMR0L. This provides the ability to read all 16-bits of Timer0, without having to verify that the read of the high and low byte were valid due to a rollover between successive reads of the high and low byte.

A write to the high byte of Timer0 must also take place through the TMR0H buffer register. Timer0 high byte is updated with the contents of TMR0H when a write occurs to TMR0L. This allows all 16-bits of Timer0 to be updated at once.

TABLE 11-1: REGISTERS ASSOCIATED WITH TIMER0

Name	Bit 7	Bit 6	Bit 5	Bit 4	Bit 3	Bit 2	Bit 1	Bit 0	Value on POR, BOR	Value on all other RESETS
TMR0L	Timer0 Module Low Byte Register								xxxx xxxx	uuuu uuuu
TMR0H	Timer0 Module High Byte Register								0000 0000	0000 0000
INTCON	GIE/GIEH	PEIE/GIEL	TMR0IE	INT0IE	RBIE	TMR0IF	INT0IF	RBIF	0000 000x	0000 000u
T0CON	TMR0ON	T08BIT	T0CS	T0SE	PSA	T0PS2	T0PS1	T0PS0	1111 1111	1111 1111
TRISA	RA7 ⁽¹⁾	RA6 ⁽¹⁾	—	PORTA Data Direction Register					11-1 1111	11-1 1111

Legend: x = unknown, u = unchanged, - = unimplemented locations read as '0'. Shaded cells are not used by Timer0.

Note 1: RA6 and RA7 are enabled as I/O pins, depending on the Oscillator mode selected in Configuration Word 1H.

PIC18F1220/1320

NOTES:

12.0 TIMER1 MODULE

The Timer1 module timer/counter has the following features:

- 16-bit timer/counter (two 8-bit registers: TMR1H and TMR1L)
- Readable and writable (both registers)
- Internal or external clock select
- Interrupt-on-overflow from FFFFh to 0000h
- RESET from CCP module special event trigger
- Status of system clock operation

Figure 12-1 is a simplified block diagram of the Timer1 module.

Register 12-1 details the Timer1 control register. This register controls the Operating mode of the Timer1 module, and contains the Timer1 oscillator enable bit (T1OSCEN). Timer1 can be enabled or disabled by setting or clearing control bit TMR1ON (T1CON<0>).

The Timer1 oscillator can be used as a secondary clock source in Power Managed modes. When the T1RUN bit is set, the Timer1 oscillator is providing the system clock. If the Fail-Safe Clock Monitor is enabled and the Timer1 oscillator fails while providing the system clock, polling the T1RUN bit will indicate whether the clock is being provided by the Timer1 oscillator or another source.

Timer1 can also be used to provide Real-Time Clock (RTC) functionality to applications, with only a minimal addition of external components and code overhead.

REGISTER 12-1: T1CON: TIMER1 CONTROL REGISTER

R/W-0	R-0	R/W-0	R/W-0	R/W-0	R/W-0	R/W-0	R/W-0
RD16	T1RUN	T1CKPS1	T1CKPS0	T1OSCEN	T1SYNC	TMR1CS	TMR1ON
bit 7						bit 0	

- bit 7 **RD16:** 16-bit Read/Write Mode Enable bit
 1 = Enables register read/write of Timer1 in one 16-bit operation
 0 = Enables register read/write of Timer1 in two 8-bit operations
- bit 6 **T1RUN:** Timer1 System Clock Status bit
 1 = System clock is derived from Timer1 oscillator
 0 = System clock is derived from another source
- bit 5-4 **T1CKPS1:T1CKPS0:** Timer1 Input Clock Prescale Select bits
 11 = 1:8 Prescale value
 10 = 1:4 Prescale value
 01 = 1:2 Prescale value
 00 = 1:1 Prescale value
- bit 3 **T1OSCEN:** Timer1 Oscillator Enable bit
 1 = Timer1 oscillator is enabled
 0 = Timer1 oscillator is shut-off
 The oscillator inverter and feedback resistor are turned off to eliminate power drain.
- bit 2 **T1SYNC:** Timer1 External Clock Input Synchronization Select bit
When TMR1CS = 1:
 1 = Do not synchronize external clock input
 0 = Synchronize external clock input
When TMR1CS = 0:
 This bit is ignored. Timer1 uses the internal clock when TMR1CS = 0.
- bit 1 **TMR1CS:** Timer1 Clock Source Select bit
 1 = External clock from pin RC0/T1OSO/T13CKI (on the rising edge)
 0 = Internal clock (FOSC/4)
- bit 0 **TMR1ON:** Timer1 On bit
 1 = Enables Timer1
 0 = Stops Timer1

Legend:

R = Readable bit

W = Writable bit

U = Unimplemented bit, read as '0'

- n = Value at POR

'1' = Bit is set

'0' = Bit is cleared

x = Bit is unknown

PIC18F1220/1320

12.1 Timer1 Operation

Timer1 can operate in one of these modes:

- As a timer
- As a synchronous counter
- As an asynchronous counter

The Operating mode is determined by the clock select bit, TMR1CS (T1CON<1>).

When TMR1CS = 0, Timer1 increments every instruction cycle. When TMR1CS = 1, Timer1 increments on every rising edge of the external clock input or the Timer1 oscillator, if enabled.

When the Timer1 oscillator is enabled (T1OSCEN is set), the RC1/T1OSI/CCP2 and RC0/T1OSO/T1CKI pins become inputs. That is, the TRISC1:TRISC0 value is ignored, and the pins are read as '0'.

Timer1 also has an internal "RESET input". This RESET can be generated by the CCP module (see Section 15.4.4, "Special Event Trigger").

FIGURE 12-1: TIMER1 BLOCK DIAGRAM

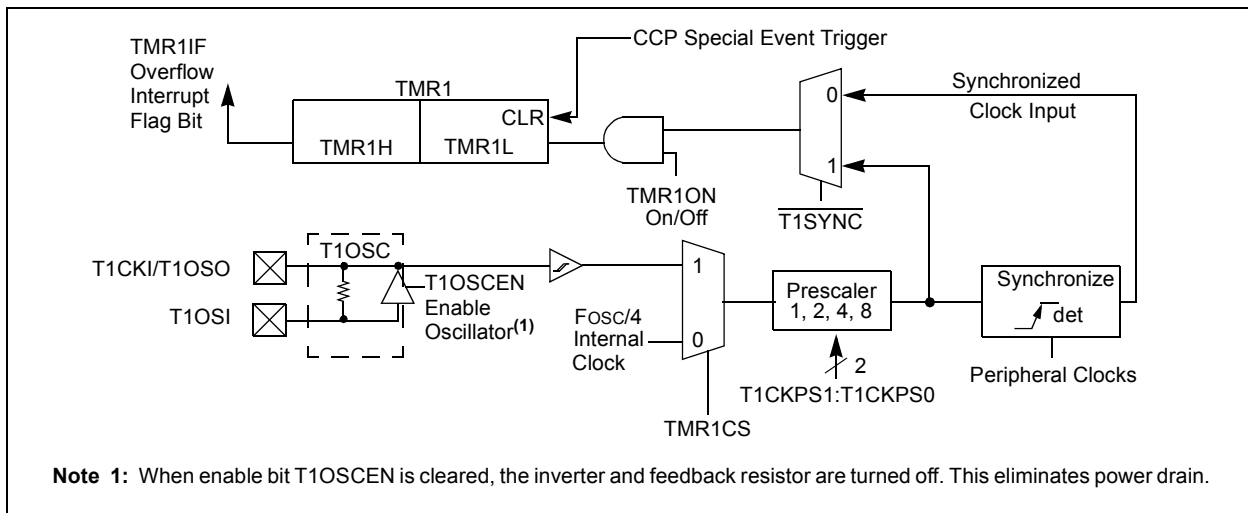
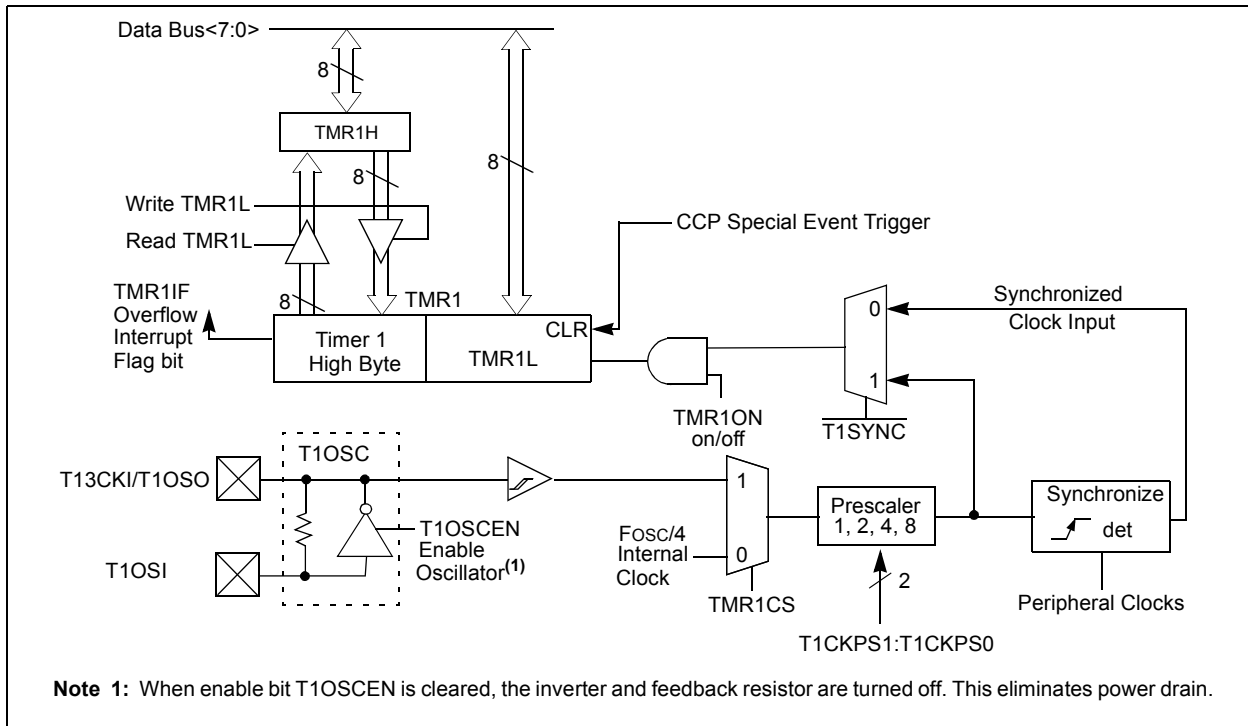

FIGURE 12-2: TIMER1 BLOCK DIAGRAM: 16-BIT READ/WRITE MODE



12.2 Timer1 Oscillator

A crystal oscillator circuit is built-in between pins T1OSI (input) and T1OSO (amplifier output). It is enabled by setting control bit T1OSCEN (T1CON<3>). The oscillator is a low power oscillator rated for 32 kHz crystals. It will continue to run during all Power Managed modes. The circuit for a typical LP oscillator is shown in Figure 12-3. Table 12-1 shows the capacitor selection for the Timer1 oscillator.

The user must provide a software time delay to ensure proper start-up of the Timer1 oscillator.

FIGURE 12-3: EXTERNAL COMPONENTS FOR THE TIMER1 LP OSCILLATOR

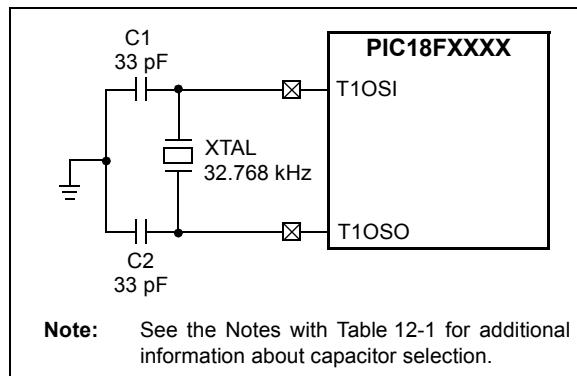

TABLE 12-1: CAPACITOR SELECTION FOR THE TIMER OSCILLATOR

Osc Type	Freq	C1	C2
LP	32 kHz	27 pF ⁽¹⁾	27 pF ⁽¹⁾

Note 1: Microchip suggests this value as a starting point in validating the oscillator circuit.

2: Higher capacitance increases the stability of the oscillator, but also increases the start-up time.

3: Since each resonator/crystal has its own characteristics, the user should consult the resonator/crystal manufacturer for appropriate values of external components.

4: Capacitor values are for design guidance only.

12.3 Timer1 Oscillator Layout Considerations

The Timer1 oscillator circuit draws very little power during operation. Due to the low power nature of the oscillator, it may also be sensitive to rapidly changing signals in close proximity.

The oscillator circuit shown in Figure 12-3 should be located as close as possible to the microcontroller. There should be no circuits passing within the oscillator circuit boundaries other than VSS or VDD.

If a high speed circuit must be located near the oscillator (such as the CCP1 pin in output compare or PWM mode, or the primary oscillator using the OSC2 pin), a grounded guard ring around the oscillator circuit, as shown in Figure 12-4, may be helpful when used on a single sided PCB, or in addition to a ground plane.

FIGURE 12-4: OSCILLATOR CIRCUIT WITH GROUNDED GUARD RING

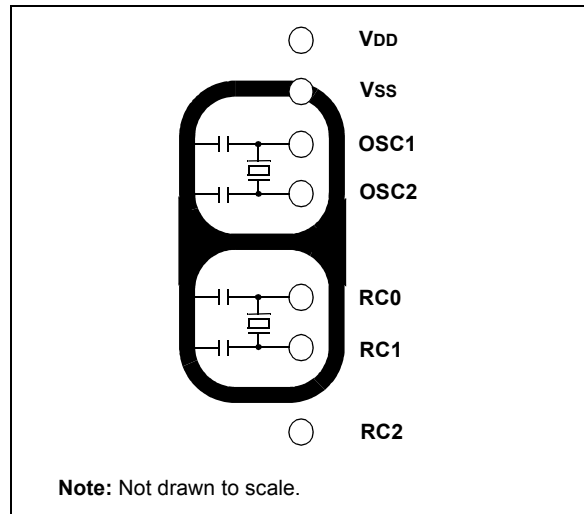

12.4 Timer1 Interrupt

The TMR1 register pair (TMR1H:TMR1L) increments from 0000h to FFFFh and rolls over to 0000h. The Timer1 interrupt, if enabled, is generated on overflow, which is latched in interrupt flag bit, TMR1IF (PIR1<0>). This interrupt can be enabled/disabled by setting/clearing Timer1 interrupt enable bit, TMR1IE (PIE1<0>).

PIC18F1220/1320

12.5 Resetting Timer1 Using a CCP Trigger Output

If the CCP module is configured in Compare mode to generate a “special event trigger” (CCP1M3:CCP1M0 = 1011), this signal will reset Timer1 and start an A/D conversion, if the A/D module is enabled (see Section 15.4.4 for more information.).

Note: The special event triggers from the CCP1 module will not set interrupt flag bit, TMR1IF (PIR1<0>).

Timer1 must be configured for either Timer or Synchronized Counter mode to take advantage of this feature. If Timer1 is running in Asynchronous Counter mode, this RESET operation may not work.

In the event that a write to Timer1 coincides with a special event trigger from CCP1, the write will take precedence.

In this mode of operation, the CCPR1H:CCPR1L registers pair effectively becomes the period register for Timer1.

12.6 Timer1 16-Bit Read/Write Mode

Timer1 can be configured for 16-bit reads and writes (see Figure 12-2). When the RD16 control bit (T1CON<7>) is set, the address for TMR1H is mapped to a buffer register for the high byte of Timer1. A read from TMR1L will load the contents of the high byte of Timer1 into the Timer1 high byte buffer. This provides the user with the ability to accurately read all 16 bits of Timer1 without having to determine whether a read of the high byte, followed by a read of the low byte, is valid, due to a rollover between reads.

A write to the high byte of Timer1 must also take place through the TMR1H buffer register. Timer1 high byte is updated with the contents of TMR1H when a write occurs to TMR1L. This allows a user to write all 16 bits to both the high and low bytes of Timer1 at once.

The high byte of Timer1 is not directly readable or writable in this mode. All reads and writes must take place through the Timer1 high byte buffer register. Writes to TMR1H do not clear the Timer1 prescaler. The prescaler is only cleared on writes to TMR1L.

12.7 Using Timer1 as a Real-Time Clock

Adding an external LP oscillator to Timer1 (such as the one described in Section 12.2, above), gives users the option to include RTC functionality to their applications. This is accomplished with an inexpensive watch crystal to provide an accurate time-base, and several lines of application code to calculate the time. When operating in SLEEP mode and using a battery or super capacitor as a power source, it can completely eliminate the need for a separate RTC device and battery backup.

The application code routine, `RTCisr`, shown in Example 12-1, demonstrates a simple method to increment a counter at one-second intervals using an Interrupt Service Routine. Incrementing the TMR1 register pair to overflow triggers the interrupt and calls the routine, which increments the seconds counter by one; additional counters for minutes and hours are incremented as the previous counter overflow.

Since the register pair is 16-bits wide, counting up to overflow the register directly from a 32.768 kHz clock would take 2 seconds. To force the overflow at the required one-second intervals, it is necessary to preload it; the simplest method is to set the MSbit of TMR1H with a `BSF` instruction. Note that the TMR1L register is never preloaded or altered; doing so may introduce cumulative error over many cycles.

For this method to be accurate, Timer1 must operate in Asynchronous mode, and the Timer1 Overflow Interrupt must be enabled (PIE1<0> = 1), as shown in the routine `RTCinit`. The Timer1 oscillator must also be enabled and running at all times.

EXAMPLE 12-1: IMPLEMENTING A REAL-TIME CLOCK USING A TIMER1 INTERRUPT SERVICE

```

RTCinit
    MOVLW    0x80          ; Preload TMR1 register pair
    MOVWF    TMR1H        ; for 1 second overflow
    CLRF     TMR1L
    MOVLW    b'00001111'  ; Configure for external clock,
    MOVWF    T1OSC        ; Asynchronous operation, external oscillator
    CLRF     secs         ; Initialize timekeeping registers
    CLRF     mins
    MOVLW    .12
    MOVWF    hours
    BSF      PIE1, TMR1IE ; Enable Timer1 interrupt
    RETURN

RTCisr
    BSF      TMR1H,7      ; Preload for 1 sec overflow
    BCF      PIR1,TMR1IF ; Clear interrupt flag
    INCF     secs,F       ; Increment seconds
    MOVLW    .59          ; 60 seconds elapsed?
    CPFSGT   secs
    RETURN                    ; No, done
    CLRF     secs         ; Clear seconds
    INCF     mins,F       ; Increment minutes
    MOVLW    .59          ; 60 minutes elapsed?
    CPFSGT   mins
    RETURN                    ; No, done
    CLRF     mins         ; clear minutes
    INCF     hours,F      ; Increment hours
    MOVLW    .23          ; 24 hours elapsed?
    CPFSGT   hours
    RETURN                    ; No, done
    MOVLW    .01          ; Reset hours to 1
    MOVWF    hours
    RETURN                    ; Done
    
```

TABLE 12-2: REGISTERS ASSOCIATED WITH TIMER1 AS A TIMER/COUNTER

Name	Bit 7	Bit 6	Bit 5	Bit 4	Bit 3	Bit 2	Bit 1	Bit 0	Value on POR, BOR	Value on all other RESETS
INTCON	GIE/GIEH	PEIE/GIEL	TMR0IE	INT0IE	RBIE	TMR0IF	INT0IF	RBIF	0000 000x	0000 000u
PIR1	PSPIF ⁽¹⁾	ADIF	RCIF	TXIF	SSPIF	CCP1IF	TMR2IF	TMR1IF	0000 0000	0000 0000
PIE1	PSPIE ⁽¹⁾	ADIE	RCIE	TXIE	SSPIE	CCP1IE	TMR2IE	TMR1IE	0000 0000	0000 0000
IPR1	PSPIP ⁽¹⁾	ADIP	RCIP	TXIP	SSPIP	CCP1IP	TMR2IP	TMR1IP	0000 0000	0000 0000
TMR1L	Holding Register for the Least Significant Byte of the 16-bit TMR1 Register								xxxx xxxx	uuuu uuuu
TMR1H	Holding Register for the Most Significant Byte of the 16-bit TMR1 Register								xxxx xxxx	uuuu uuuu
T1CON	RD16	T1RUN	T1CKPS1	T1CKPS0	T1OSCN	T1SYNC	TMR1CS	TMR1ON	0000 0000	u0uu uuuu

Legend: x = unknown, u = unchanged, - = unimplemented, read as '0'. Shaded cells are not used by the Timer1 module.

Note 1: The PSPIF, PSPIE and PSPIP bits are reserved on the PIC18F1220/1320 devices; always maintain these bits clear.

PIC18F1220/1320

NOTES:

13.0 TIMER2 MODULE

The Timer2 module timer has the following features:

- 8-bit timer (TMR2 register)
- 8-bit period register (PR2)
- Readable and writable (both registers)
- Software programmable prescaler (1:1, 1:4, 1:16)
- Software programmable postscaler (1:1 to 1:16)
- Interrupt on TMR2 match with PR2

Timer2 has a control register shown in Register 13-1. TMR2 can be shut-off by clearing control bit TMR2ON (T2CON<2>) to minimize power consumption. Figure 13-1 is a simplified block diagram of the Timer2 module. Register 13-1 shows the Timer2 control register. The prescaler and postscaler selection of Timer2 are controlled by this register.

13.1 Timer2 Operation

Timer2 can be used as the PWM time-base for the PWM mode of the CCP module. The TMR2 register is readable and writable, and is cleared on any device RESET. The input clock ($F_{osc}/4$) has a prescale option of 1:1, 1:4 or 1:16, selected by control bits T2CKPS1:T2CKPS0 (T2CON<1:0>). The match output of TMR2 goes through a 4-bit postscaler (which gives a 1:1 to 1:16 scaling inclusive) to generate a TMR2 interrupt (latched in flag bit TMR2IF, (PIR1<1>)).

The prescaler and postscaler counters are cleared when any of the following occurs:

- A write to the TMR2 register
- A write to the T2CON register
- Any device RESET (Power-on Reset, \overline{MCLR} Reset, Watchdog Timer Reset, or Brown-out Reset)

TMR2 is not cleared when T2CON is written.

REGISTER 13-1: T2CON: TIMER2 CONTROL REGISTER

U-0	R/W-0	R/W-0	R/W-0	R/W-0	R/W-0	R/W-0	R/W-0
—	TOUTPS3	TOUTPS2	TOUTPS1	TOUTPS0	TMR2ON	T2CKPS1	T2CKPS0
bit 7							bit 0

- bit 7 **Unimplemented:** Read as '0'
- bit 6-3 **TOUTPS3:TOUTPS0:** Timer2 Output Postscale Select bits
 0000 = 1:1 postscale
 0001 = 1:2 postscale
 •
 •
 •
 1111 = 1:16 postscale
- bit 2 **TMR2ON:** Timer2 On bit
 1 = Timer2 is on
 0 = Timer2 is off
- bit 1-0 **T2CKPS1:T2CKPS0:** Timer2 Clock Prescale Select bits
 00 = Prescaler is 1
 01 = Prescaler is 4
 1x = Prescaler is 16

Legend:

R = Readable bit	W = Writable bit	U = Unimplemented bit, read as '0'
- n = Value at POR	'1' = Bit is set	'0' = Bit is cleared x = Bit is unknown

PIC18F1220/1320

13.2 Timer2 Interrupt

The Timer2 module has an 8-bit period register, PR2. Timer2 increments from 00h until it matches PR2 and then resets to 00h on the next increment cycle. PR2 is a readable and writable register. The PR2 register is initialized to FFh upon RESET.

13.3 Output of TMR2

The output of TMR2 (before the postscaler) is fed to the Synchronous Serial Port module, which optionally uses it to generate the shift clock.

FIGURE 13-1: TIMER2 BLOCK DIAGRAM

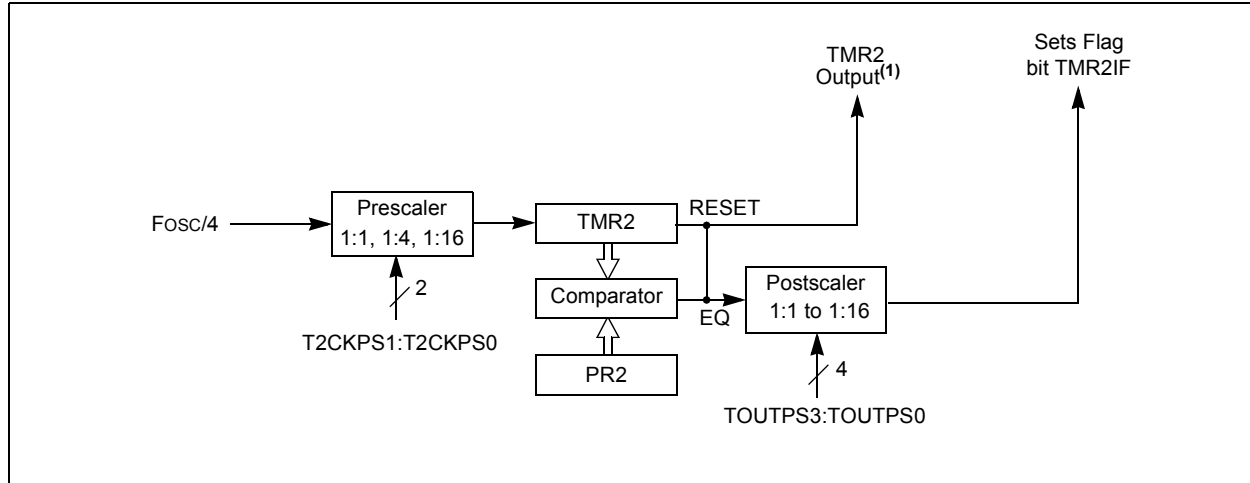

TABLE 13-1: REGISTERS ASSOCIATED WITH TIMER2 AS A TIMER/COUNTER

Name	Bit 7	Bit 6	Bit 5	Bit 4	Bit 3	Bit 2	Bit 1	Bit 0	Value on POR, BOR	Value on all other RESETS
INTCON	GIE/GIEH	PEIE/GIEL	TMR0IE	INT0IE	RBIE	TMR0IF	INT0IF	RBIF	0000 000x	0000 000u
PIR1	—	ADIF	RCIF	TXIF	—	CCP1IF	TMR2IF	TMR1IF	-000 -000	0000 0000
PIE1	—	ADIE	RCIE	TXIE	—	CCP1IE	TMR2IE	TMR1IE	-000 -000	0000 0000
IPR1	—	ADIP	RCIP	TXIP	—	CCP1IP	TMR2IP	TMR1IP	-000 -000	0000 0000
TMR2	Timer2 Module Register								0000 0000	0000 0000
T2CON	—	TOUTPS3	TOUTPS2	TOUTPS1	TOUTPS0	TMR2ON	T2CKPS1	T2CKPS0	-000 0000	-000 0000
PR2	Timer2 Period Register								1111 1111	1111 1111

Legend: x = unknown, u = unchanged, - = unimplemented, read as '0'. Shaded cells are not used by the Timer2 module.

14.0 TIMER3 MODULE

The Timer3 module timer/counter has the following features:

- 16-bit timer/counter (two 8-bit registers; TMR3H and TMR3L)
- Readable and writable (both registers)
- Internal or external clock select
- Interrupt-on-overflow from FFFFh to 0000h
- RESET from CCP module trigger

Figure 14-1 is a simplified block diagram of the Timer3 module.

Register 14-1 shows the Timer3 control register. This register controls the Operating mode of the Timer3 module and sets the CCP clock source.

Register 12-1 shows the Timer1 control register. This register controls the Operating mode of the Timer1 module, as well as contains the Timer1 oscillator enable bit (T1OSCEN), which can be a clock source for Timer3.

REGISTER 14-1: T3CON: TIMER3 CONTROL REGISTER

R/W-0	R/W-0	R/W-0	R/W-0	R/W-0	R/W-0	R/W-0	R/W-0
RD16	T3CCP2	T3CKPS1	T3CKPS0	T3CCP1	T3SYNC	TMR3CS	TMR3ON
bit 7						bit 0	

- bit 7 **RD16:** 16-bit Read/Write Mode Enable bit
 1 = Enables register Read/Write of Timer3 in one 16-bit operation
 0 = Enables register Read/Write of Timer3 in two 8-bit operations
- bit 6, 3 **T3CCP2:T3CCP1:** Timer3 and Timer1 to CCPx Enable bits
 1x = Timer3 is the clock source for compare/capture CCP modules
 0x = Timer1 is the clock source for compare/capture CCP modules
- bit 5-4 **T3CKPS1:T3CKPS0:** Timer3 Input Clock Prescale Select bits
 11 = 1:8 prescale value
 10 = 1:4 prescale value
 01 = 1:2 prescale value
 00 = 1:1 prescale value
- bit 2 **T3SYNC:** Timer3 External Clock Input Synchronization Control bit
 (Not usable if the system clock comes from Timer1/Timer3.)
When TMR3CS = 1:
 1 = Do not synchronize external clock input
 0 = Synchronize external clock input
When TMR3CS = 0:
 This bit is ignored. Timer3 uses the internal clock when TMR3CS = 0.
- bit 1 **TMR3CS:** Timer3 Clock Source Select bit
 1 = External clock input from Timer1 oscillator or T1CKI
 (on the rising edge after the first falling edge)
 0 = Internal clock (Fosc/4)
- bit 0 **TMR3ON:** Timer3 On bit
 1 = Enables Timer3
 0 = Stops Timer3

Legend:

R = Readable bit	W = Writable bit	U = Unimplemented bit, read as '0'
- n = Value at POR	'1' = Bit is set	'0' = Bit is cleared x = Bit is unknown

PIC18F1220/1320

14.1 Timer3 Operation

Timer3 can operate in one of these modes:

- As a timer
- As a synchronous counter
- As an asynchronous counter

The Operating mode is determined by the clock select bit, TMR3CS (T3CON<1>).

When TMR3CS = 0, Timer3 increments every instruction cycle. When TMR3CS = 1, Timer3 increments on every rising edge of the Timer1 external clock input or the Timer1 oscillator, if enabled.

When the Timer1 oscillator is enabled (T1OSCEN is set), the RB7/PGD/T1OSI/P1D/KBI3 and RB6/PGC/T1OSO/T1CKI/P1C/KBI2 pins become inputs. That is, the TRISB7:TRISB6 value is ignored, and the pins are read as '0'.

Timer3 also has an internal "RESET input". This RESET can be generated by the CCP module (see Section 15.4.4, "Special Event Trigger").

FIGURE 14-1: TIMER3 BLOCK DIAGRAM

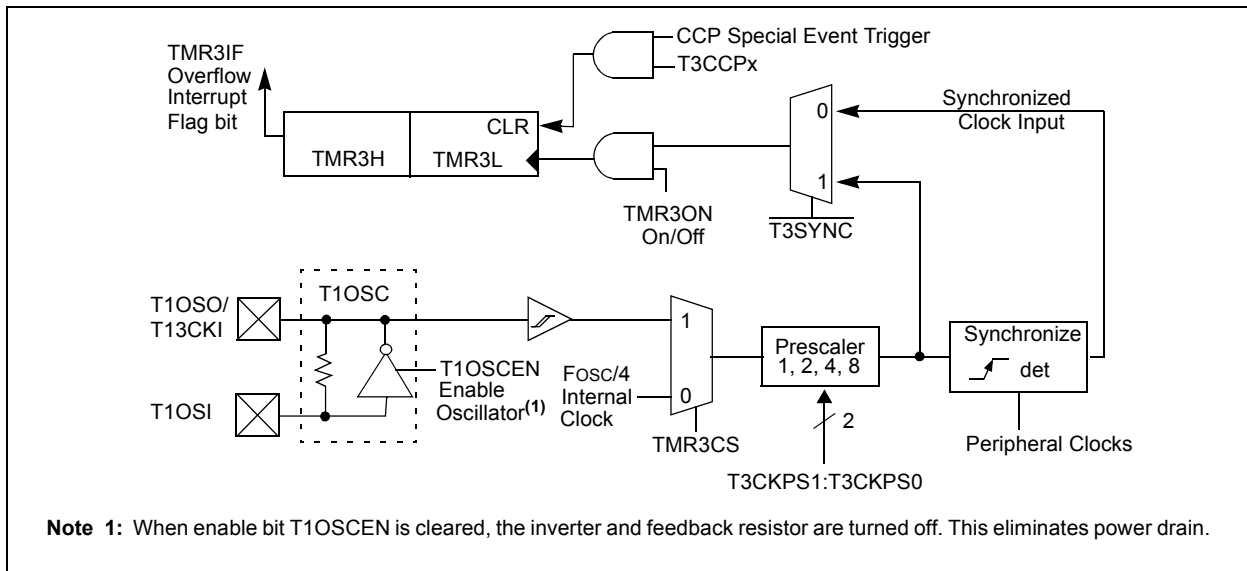
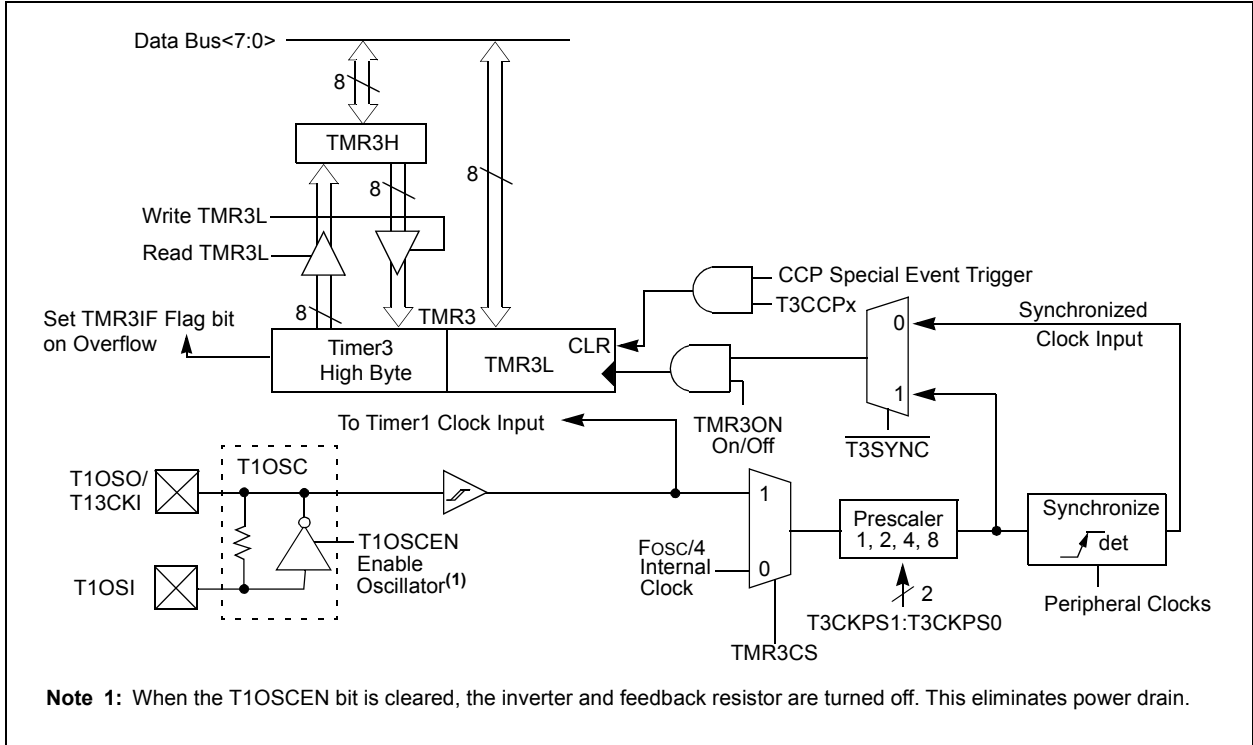

FIGURE 14-2: TIMER3 BLOCK DIAGRAM CONFIGURED IN 16-BIT READ/WRITE MODE



PIC18F1220/1320

14.2 Timer1 Oscillator

The Timer1 oscillator may be used as the clock source for Timer3. The Timer1 oscillator is enabled by setting the T1OSCEN (T1CON<3>) bit. The oscillator is a low power oscillator rated for 32 kHz crystals. See Section 12.2 for further details.

14.3 Timer3 Interrupt

The TMR3 Register pair (TMR3H:TMR3L) increments from 0000h to FFFFh and rolls over to 0000h. The TMR3 Interrupt, if enabled, is generated on overflow, which is latched in interrupt flag bit, TMR3IF (PIR2<1>). This interrupt can be enabled/disabled by setting/clearing TMR3 interrupt enable bit, TMR3IE (PIE2<1>).

14.4 Resetting Timer3 Using a CCP Trigger Output

If the CCP module is configured in Compare mode to generate a “special event trigger” (CCP1M3:CCP1M0 = 1011), this signal will reset Timer3. See Section 15.4.4 for more information.

Note: The special event triggers from the CCP module will not set interrupt flag bit, TMR3IF (PIR1<0>).

Timer3 must be configured for either Timer or Synchronized Counter mode to take advantage of this feature. If Timer3 is running in Asynchronous Counter mode, this RESET operation may not work. In the event that a write to Timer3 coincides with a special event trigger from CCP1, the write will take precedence. In this mode of operation, the CCPR1H:CCPR1L registers pair effectively becomes the period register for Timer3.

TABLE 14-1: REGISTERS ASSOCIATED WITH TIMER3 AS A TIMER/COUNTER

Name	Bit 7	Bit 6	Bit 5	Bit 4	Bit 3	Bit 2	Bit 1	Bit 0	Value on POR, BOR	Value on all other RESETS
INTCON	GIE/GIEH	PEIE/GIEL	TMR0IE	INT0IE	RBIE	TMR0IF	INT0IF	RBIF	0000 000x	0000 000u
PIR2	OSCIF	—	—	EEIF	—	LVDIF	TMR3IF	—	0--0 -00-	0--0 -00-
PIE2	OSCIIE	—	—	EEIE	—	LVDIE	TMR3IE	—	0--0 -00-	0--0 -00-
IPR2	OSCIIP	—	—	EEIP	—	LVDIP	TMR3IP	—	1--1 -11-	1--1 -11-
TMR3L	Holding Register for the Least Significant Byte of the 16-bit TMR3 Register								xxxx xxxx	uuuu uuuu
TMR3H	Holding Register for the Most Significant Byte of the 16-bit TMR3 Register								xxxx xxxx	uuuu uuuu
T1CON	RD16	T1RUN	T1CKPS1	T1CKPS0	T1OSCEN	$\overline{T1SYNC}$	TMR1CS	TMR1ON	0000 0000	u0uu uuuu
T3CON	RD16	T3CCP2	T3CKPS1	T3CKPS0	T3CCP1	$\overline{T3SYNC}$	TMR3CS	TMR3ON	0000 0000	uuuu uuuu

Legend: x = unknown, u = unchanged, - = unimplemented, read as '0'. Shaded cells are not used by the Timer3 module.

15.0 ENHANCED CAPTURE/COMPARE/PWM (ECCP) MODULE

The enhanced CCP module is implemented as a standard CCP module with enhanced PWM capabilities. These capabilities allow for 2 or 4 output channels, user selectable polarity, deadband control, and automatic shutdown and restart, and are discussed in detail in Section 15.5.

The control register for CCP1 is shown in Register 15-1.

In addition to the expanded functions of the CCP1CON register, the ECCP module has two additional registers associated with enhanced PWM operation and auto shutdown features:

- PWM1CON
- ECCPAS

REGISTER 15-1: CCP1CON REGISTER FOR ENHANCED CCP OPERATION

R/W-0	R/W-0	R/W-0	R/W-0	R/W-0	R/W-0	R/W-0	R/W-0	
P1M1	P1M0	DC1B1	DC1B0	CCP1M3	CCP1M2	CCP1M1	CCP1M0	
bit 7								bit 0

bit 7-6 **P1M1:P1M0:** PWM Output Configuration bits

If $CCP1M\langle 3:2 \rangle = 00, 01, 10$:

xx = P1A assigned as Capture/Compare input; P1B, P1C, P1D assigned as port pins

If $CCP1M\langle 3:2 \rangle = 11$:

00 = Single output; P1A modulated; P1B, P1C, P1D assigned as port pins

01 = Full-bridge output forward; P1D modulated; P1A active; P1B, P1C inactive

10 = Half-bridge output; P1A, P1B modulated with deadband control; P1C, P1D assigned as port pins

11 = Full-bridge output reverse; P1B modulated; P1C active; P1A, P1D inactive

bit 5-4 **DC1B1:DC1B0:** PWM Duty Cycle Least Significant bits

Capture mode:

Unused

Compare mode:

Unused

PWM mode:

These bits are the two LSbs of the PWM duty cycle. The eight MSBs are found in CCPR1L.

bit 3-0 **CCP1M3:CCP1M0:** ECCP1 Mode Select bits

0000 = Capture/Compare/PWM off (resets ECCP module)

0001 = Unused (reserved)

0010 = Compare mode, toggle output on match (ECCP1IF bit is set)

0011 = Unused (reserved)

0100 = Capture mode, every falling edge

0101 = Capture mode, every rising edge

0110 = Capture mode, every 4th rising edge

0111 = Capture mode, every 16th rising edge

1000 = Compare mode, set output on match (ECCP1IF bit is set)

1001 = Compare mode, clear output on match (ECCP1IF bit is set)

1010 = Compare mode, generate software interrupt on match (ECCP1IF bit is set, ECCP1 pin is unaffected)

1011 = Compare mode, trigger special event (ECCP1IF bit is set; ECCP resets TMR1 or TMR2 and starts an A/D conversion, if the A/D module is enabled)

1100 = PWM mode; P1A, P1C active high; P1B, P1D active high

1101 = PWM mode; P1A, P1C active high; P1B, P1D active low

1110 = PWM mode; P1A, P1C active low; P1B, P1D active high

1111 = PWM mode; P1A, P1C active low; P1B, P1D active low

Legend:

R = Readable bit

W = Writable bit

U = Unimplemented bit, read as '0'

- n = Value at POR

'1' = Bit is set

'0' = Bit is cleared

x = Bit is unknown

PIC18F1220/1320

15.1 ECCP Outputs

The enhanced CCP module may have up to four outputs, depending on the selected operating mode. These outputs, designated P1A through P1D, are multiplexed with I/O pins on PORTB. The pin assignments are summarized in Table 15-1.

To configure I/O pins as PWM outputs, the proper PWM mode must be selected by setting the P1Mn and CCP1Mn bits (CCP1CON<7:6> and <3:0>, respectively). The appropriate TRISB direction bits for the port pins must also be set as outputs.

TABLE 15-1: PIN ASSIGNMENTS FOR VARIOUS ECCP MODES

ECCP Mode	CCP1CON Configuration	RB3	RB2	RB6	RB7
Compatible CCP	00xx11xx	CCP1	RB2/INT2	RB6/PGC/T1OSO/T1CKI/KBI2	RB7/PGD/T1OSI/KBI3
Dual PWM	10xx11xx	P1A	P1B	RB6/PGC/T1OSO/T1CKI/KBI2	RB7/PGD/T1OSI/KBI3
Quad PWM	x1xx11xx	P1A	P1B	P1C	P1D

Legend: x = Don't care. Shaded cells indicate pin assignments not used by ECCP in a given mode.

Note 1: TRIS register values must be configured appropriately.

15.2 CCP Module

Capture/Compare/PWM Register 1 (CCPR1) is comprised of two 8-bit registers: CCPR1L (low byte) and CCPR1H (high byte). The CCP1CON register controls the operation of CCP1. All are readable and writable.

TABLE 15-2: CCP MODE - TIMER RESOURCE

CCP Mode	Timer Resource
Capture	Timer1 or Timer3
Compare	Timer1 or Timer3
PWM	Timer2

15.3 Capture Mode

In Capture mode, CCPR1H:CCPR1L captures the 16-bit value of the TMR1 or TMR3 registers when an event occurs on pin RC2/CCP1. An event is defined as one of the following:

- every falling edge
- every rising edge
- every 4th rising edge
- every 16th rising edge

The event is selected by control bits CCP1M3:CCP1M0 (CCP1CON<3:0>). When a capture is made, the interrupt request flag bit CCP1IF (PIR1<2>) is set; it must be cleared in software. If another capture occurs before the value in register CCPR1 is read, the old captured value is overwritten by the new captured value.

15.3.1 CCP PIN CONFIGURATION

In Capture mode, the RB3/CCP1 pin should be configured as an input by setting the TRISB<3> bit.

Note: If the RB3/CCP1 is configured as an output, a write to the port can cause a capture condition.

15.3.2 TIMER1/TIMER3 MODE SELECTION

The timers that are to be used with the capture feature (either Timer1 and/or Timer3) must be running in Timer mode or Synchronized Counter mode. In Asynchronous Counter mode, the capture operation may not work. The timer to be used with each CCP module is selected in the T3CON register.

15.3.3 SOFTWARE INTERRUPT

When the Capture mode is changed, a false capture interrupt may be generated. The user should keep bit CCP1IE (PIE1<2>) clear to avoid false interrupts and should clear the flag bit, CCP1IF, following any such change in Operating mode.

15.3.4 CCP PRESCALER

There are four prescaler settings, specified by bits CCP1M3:CCP1M0. Whenever the CCP module is turned off or the CCP module is not in Capture mode, the prescaler counter is cleared. This means that any RESET will clear the prescaler counter.

Switching from one capture prescaler to another may generate an interrupt. Also, the prescaler counter will not be cleared; therefore, the first capture may be from a non-zero prescaler. Example 15-1 shows the recom-

mended method for switching between capture prescalers. This example also clears the prescaler counter and will not generate the “false” interrupt.

EXAMPLE 15-1: CHANGING BETWEEN CAPTURE PRESCALERS

```
CLRF    CCP1CON, F    ; Turn CCP module off
MOVLW  NEW_CAPT_PS   ; Load WREG with the
                                ; new prescaler mode
                                ; value and CCP ON
MOVWF  CCP1CON        ; Load CCP1CON with
                                ; this value
```

FIGURE 15-1: CAPTURE MODE OPERATION BLOCK DIAGRAM

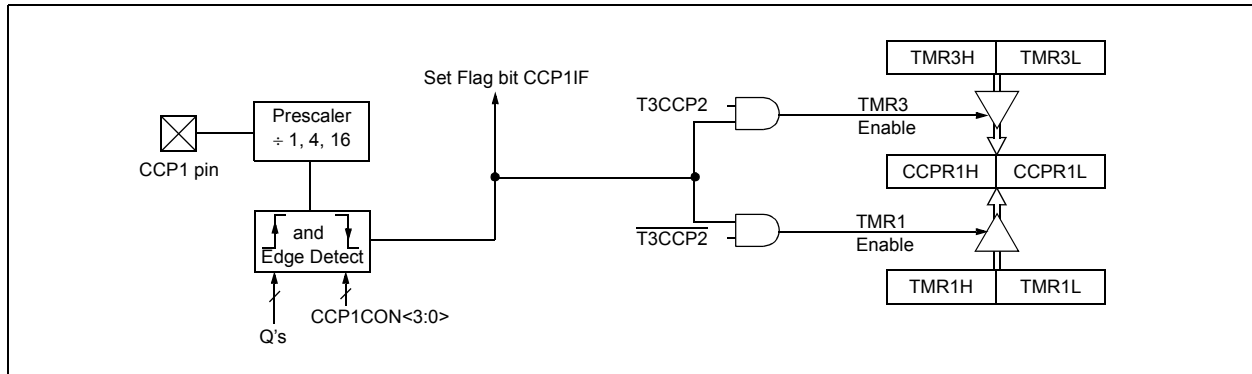

15.4 Compare Mode

In Compare mode, the 16-bit CCPR1 register value is constantly compared against either the TMR1 register pair value, or the TMR3 register pair value. When a match occurs, the RC2/CCP1 pin:

- Is driven High
- Is driven Low
- Toggles output (High to Low or Low to High)
- Remains unchanged (interrupt only)

The action on the pin is based on the value of control bits CCP1M3:CCP1M0 (CCP2M3:CCP2M0). At the same time, interrupt flag bit CCP1IF (CCP2IF) is set.

15.4.1 CCP PIN CONFIGURATION

The user must configure the CCPx pin as an output by clearing the appropriate TRISB bit.

Note: Clearing the CCP1CON register will force the RB3/CCP1/P1A compare output latch to the default low level. This is not the PORTB I/O data latch.

15.4.2 TIMER1/TIMER3 MODE SELECTION

Timer1 and/or Timer3 must be running in Timer mode or Synchronized Counter mode, if the CCP module is using the compare feature. In Asynchronous Counter mode, the compare operation may not work.

15.4.3 SOFTWARE INTERRUPT MODE

When generate software interrupt is chosen, the CCP1 pin is not affected. Only a CCP interrupt is generated (if enabled).

15.4.4 SPECIAL EVENT TRIGGER

In this mode, an internal hardware trigger is generated, which may be used to initiate an action.

The special event trigger output of CCP1 resets the TMR1 register pair. This allows the CCPR1 register to effectively be a 16-bit programmable period register for Timer1.

PIC18F1220/1320

FIGURE 15-2: COMPARE MODE OPERATION BLOCK DIAGRAM

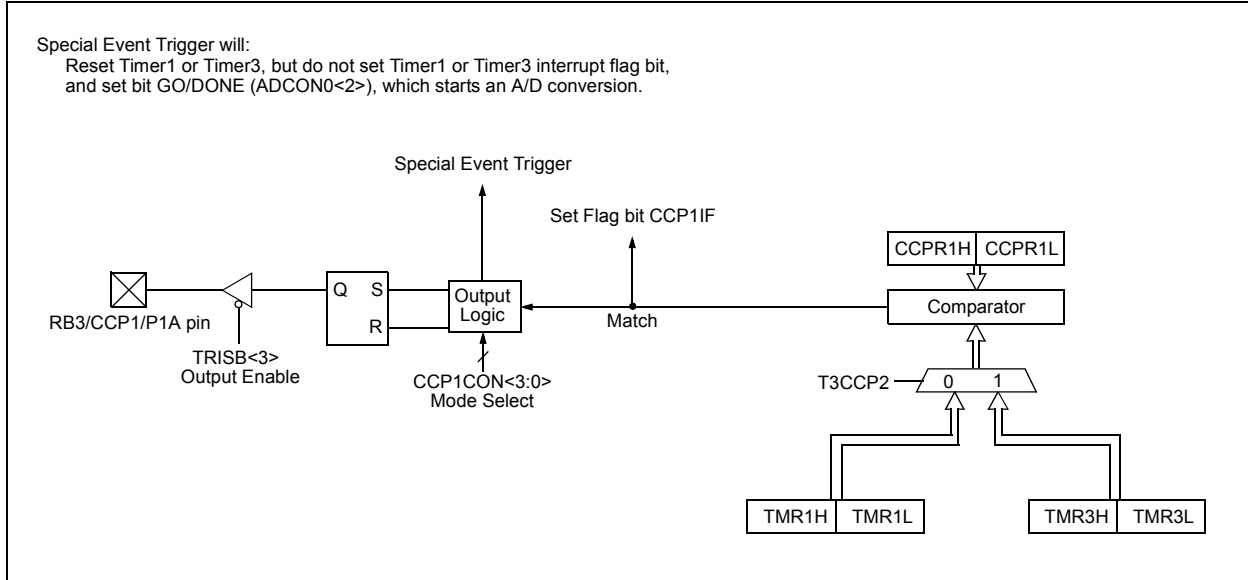

FIGURE 15-3: REGISTERS ASSOCIATED WITH CAPTURE, COMPARE, TIMER1 AND TIMER3

Name	Bit 7	Bit 6	Bit 5	Bit 4	Bit 3	Bit 2	Bit 1	Bit 0	Value on POR, BOR	Value on all other RESETS
INTCON	GIE/GIEH	PEIE/GIEL	TMR0IE	INT0IE	RBIE	TMR0IF	INT0IF	RBIF	0000 000x	0000 000u
PIR1	—	ADIF	RCIF	TXIF	—	CCP1IF	TMR2IF	TMR1IF	-000 -000	-000 -000
PIE1	—	ADIE	RCIE	TXIE	—	CCP1IE	TMR2IE	TMR1IE	-000 -000	-000 -000
IPR1	—	ADIP	RCIP	TXIP	—	CCP1IP	TMR2IP	TMR1IP	-000 -000	-000 -000
TRISB	PORTB Data Direction Register								1111 1111	1111 1111
TMR1L	Holding Register for the Least Significant Byte of the 16-bit TMR1 Register								xxxx xxxx	uuuu uuuu
TMR1H	Holding Register for the Most Significant Byte of the 16-bit TMR1 Register								xxxx xxxx	uuuu uuuu
T1CON	RD16	T1RUN	T1CKPS1	T1CKPS0	T1OSCEN	T1SYN \bar{C}	TMR1CS	TMR1ON	0000 0000	uuuu uuuu
CCPR1L	Capture/Compare/PWM Register1 (LSB)								xxxx xxxx	uuuu uuuu
CCPR1H	Capture/Compare/PWM Register1 (MSB)								xxxx xxxx	uuuu uuuu
CCP1CON	—	—	DC1B1	DC1B0	CCP1M3	CCP1M2	CCP1M1	CCP1M0	--00 0000	--00 0000
TMR3L	Holding Register for the Least Significant Byte of the 16-bit TMR3 Register								xxxx xxxx	uuuu uuuu
TMR3H	Holding Register for the Most Significant Byte of the 16-bit TMR3 Register								xxxx xxxx	uuuu uuuu
T3CON	RD16	T3CCP2	T3CKPS1	T3CKPS0	T3CCP1	T3SYN \bar{C}	TMR3CS	TMR3ON	0000 0000	uuuu uuuu

Legend: x = unknown, u = unchanged, - = unimplemented, read as '0'. Shaded cells are not used by Capture and Timer1.

15.5 Enhanced PWM Mode

The Enhanced PWM Mode provides additional PWM output options for a broader range of control applications. The module is an upwardly compatible version of the standard CCP module, and offers up to four outputs, designated P1A through P1D. Users are also able to select the polarity of the signal (either active high or active low). The module's Output mode and polarity are configured by setting the P1M1:P1M0 and CCP1M3CCP1M0 bits of the CCP1CON register (CCP1CON<7:6> and CCP1CON<3:0>, respectively).

Figure 15-4 shows a simplified block diagram of PWM operation. All control registers are double-buffered, and are loaded at the beginning of a new PWM cycle (the period boundary when Timer2 resets), in order to prevent glitches on any of the outputs. The exception is the PWM delay register ECCP1DEL, which is loaded at either the duty cycle boundary, or the boundary period (whichever comes first). Because of the buffering, the module waits until the assigned timer resets, instead of starting immediately. This means that enhanced PWM waveforms do not exactly match the standard PWM waveforms, but are instead offset by one full instruction cycle (4 TOSC).

As before, the user must manually configure the appropriate TRIS bits for output.

15.5.1 PWM PERIOD

The PWM period is specified by writing to the PR2 register. The PWM period can be calculated using the equation:

$$\text{PWM Period} = [(PR2) + 1] \cdot 4 \cdot T_{OSC} \cdot (\text{TMR2 Prescale Value})$$

PWM frequency is defined as $1 / [\text{PWM period}]$. When TMR2 is equal to PR2, the following three events occur on the next increment cycle:

- TMR2 is cleared
- The CCP1 pin is set (if PWM duty cycle = 0%, the CCP1 pin will not be set)
- The PWM duty cycle is copied from CCPR1L into CCPR1H

Note: The Timer2 postscaler (see Section 13.0) is not used in the determination of the PWM frequency. The postscaler could be used to have a servo update rate at a different frequency than the PWM output.

15.5.2 PWM DUTY CYCLE

The PWM duty cycle is specified by writing to the CCPR1L register and to the CCP1CON<5:4> bits. Up to 10-bit resolution is available. The CCPR1L contains the eight MSBs and the CCP1CON<5:4> contains the two LSbs. This 10-bit value is represented by CCP1L:CCP1CON<5:4>. The PWM duty cycle is calculated by the equation:

$$\text{PWM Duty Cycle} = (\text{CCPR1L:CCP1CON<5:4>}) \cdot T_{OSC} \cdot (\text{TMR2 Prescale Value})$$

CCPR1L and CCP1CON<5:4> can be written to at any time, but the duty cycle value is not copied into CCPR1H until a match between PR2 and TMR2 occurs (i.e., the period is complete). In PWM mode, CCPR1H is a read only register.

The CCPR1H register and a 2-bit internal latch are used to double-buffer the PWM duty cycle. This double buffering is essential for glitchless PWM operation. When the CCPR1H and 2-bit latch match TMR2, concatenated with an internal 2-bit Q clock or two bits of the TMR2 prescaler, the CCP1 pin is cleared. The maximum PWM resolution (bits) for a given PWM frequency is given by the equation:

$$\text{PWM Resolution (max)} = \frac{\log\left(\frac{F_{OSC}}{F_{PWM}}\right)}{\log(2)} \text{ bits}$$

Note: If the PWM duty cycle value is longer than the PWM period, the CCP1 pin will not be cleared.

15.5.3 PWM OUTPUT CONFIGURATIONS

The P1M1:P1M0 bits in the CCP1CON register allow one of four configurations:

- Single Output
- Half-Bridge Output
- Full-Bridge Output, Forward mode
- Full-Bridge Output, Reverse mode

The Single Output mode is the Standard PWM mode discussed in Section 15.5. The Half-Bridge and Full-Bridge Output modes are covered in detail in the sections that follow.

The general relationship of the outputs in all configurations is summarized in Figure 15-5.

TABLE 15-3: EXAMPLE PWM FREQUENCIES AND RESOLUTIONS AT 40 MHz

PWM Frequency	2.44 kHz	9.77 kHz	39.06 kHz	156.25 kHz	312.50 kHz	416.67 kHz
Timer Prescaler (1, 4, 16)	16	4	1	1	1	1
PR2 Value	FFh	FFh	FFh	3Fh	1Fh	17h
Maximum Resolution (bits)	10	10	10	8	7	6.58

PIC18F1220/1320

FIGURE 15-4: SIMPLIFIED BLOCK DIAGRAM OF THE ENHANCED PWM MODULE

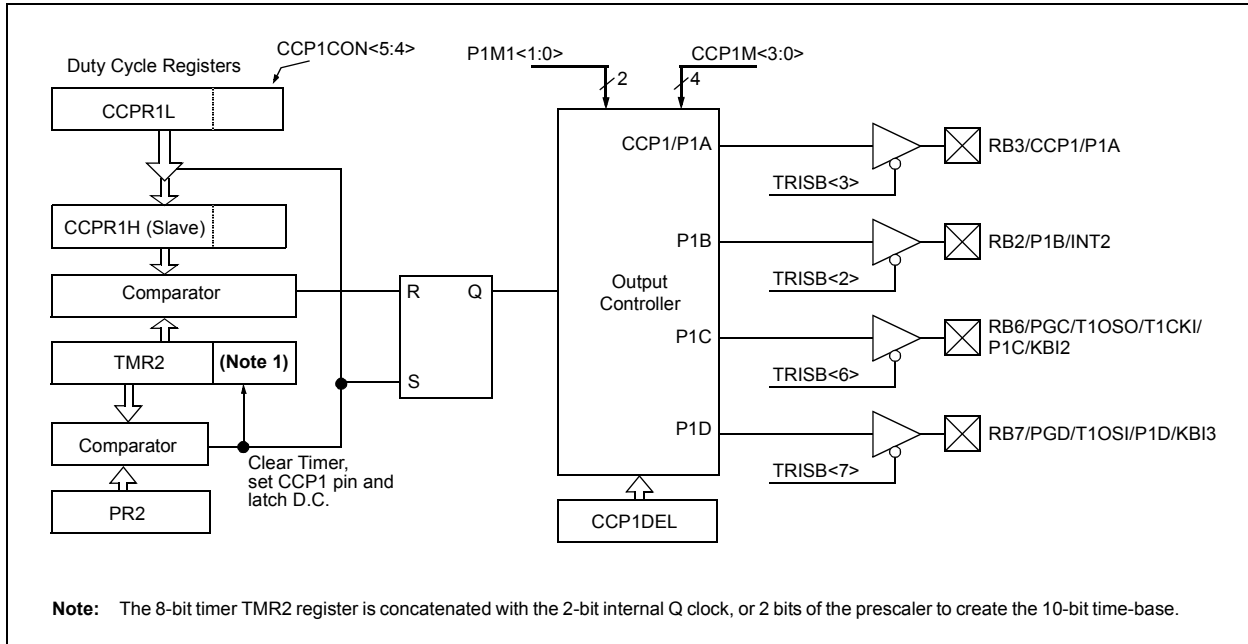

FIGURE 15-5: PWM OUTPUT RELATIONSHIPS (ACTIVE HIGH STATE)

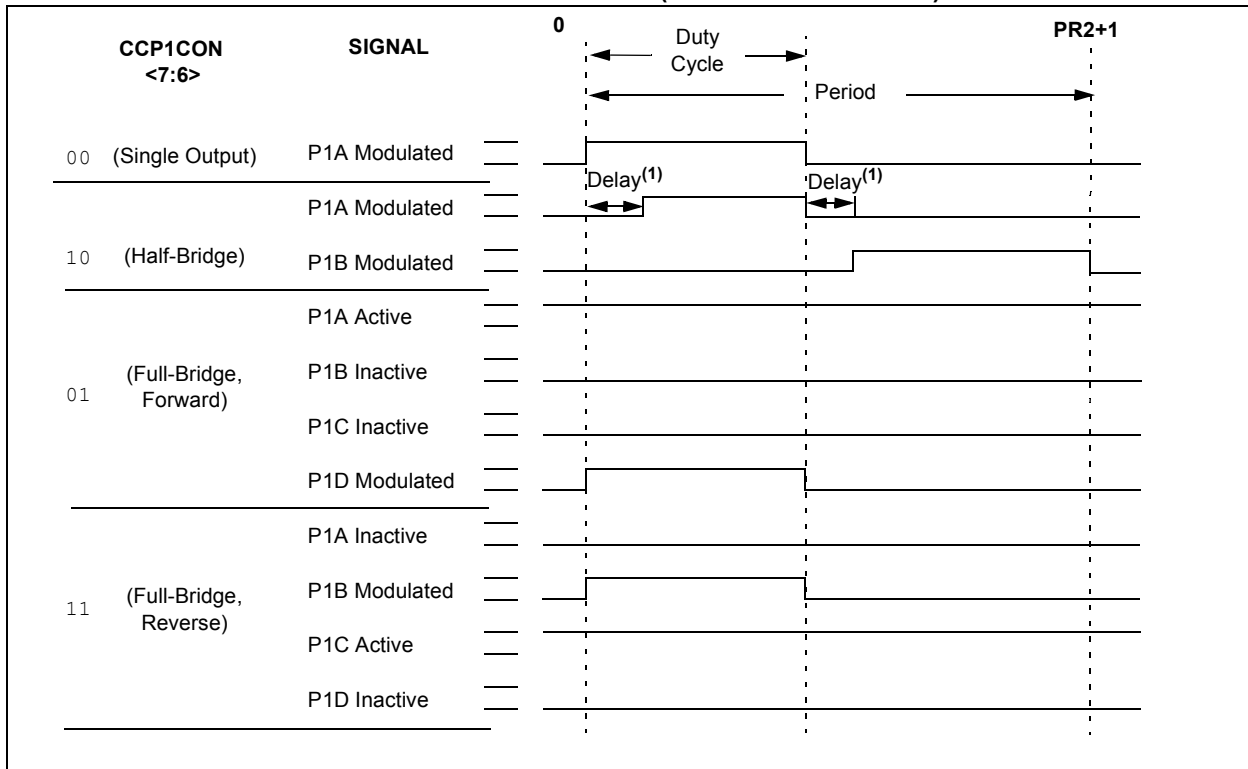
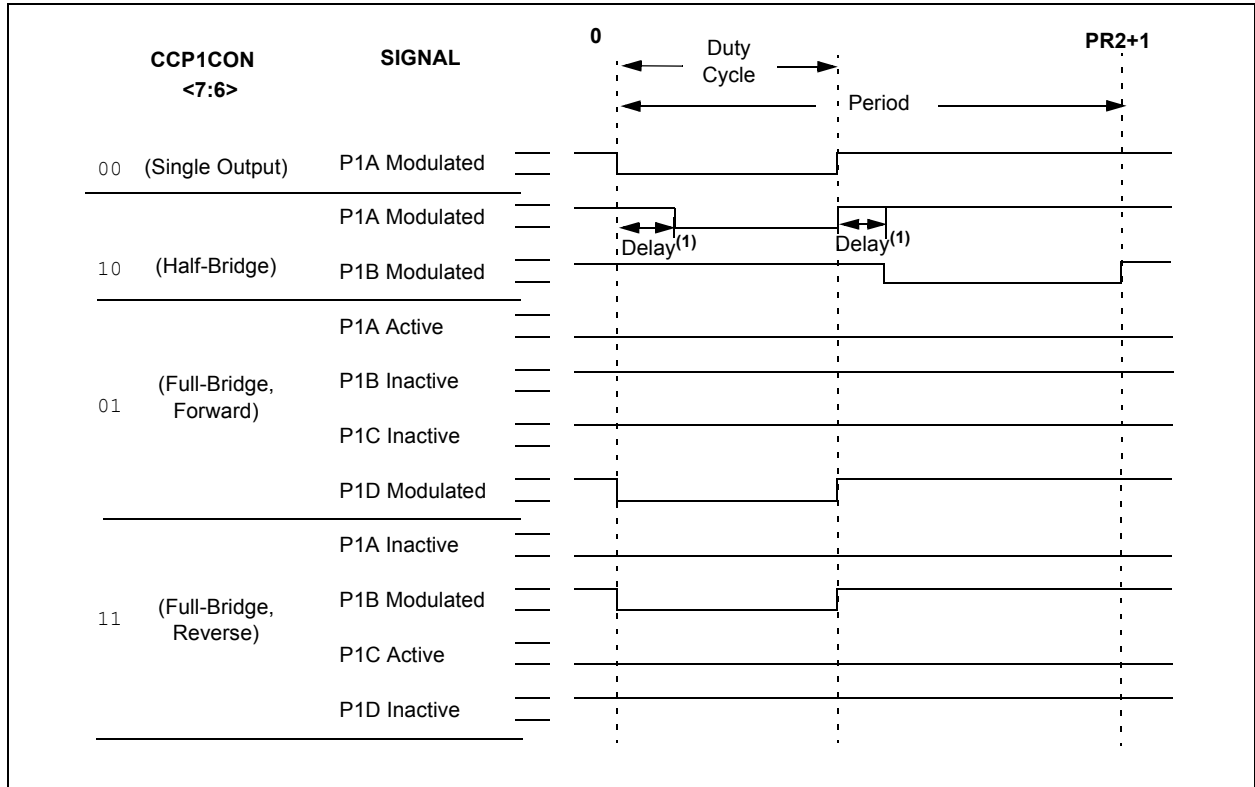

FIGURE 15-6: PWM OUTPUT RELATIONSHIPS (ACTIVE LOW STATE)



Relationships:

- Period = $4 * T_{osc} * (PR2 + 1) * (TMR2 \text{ prescale value})$
- Duty Cycle = $T_{osc} * (CCPR1L<7:0>:CCP1CON<5:4>) * (TMR2 \text{ prescale value})$
- Delay = $4 * T_{osc} * (PWM1CON<6:0>)$

Note 1: Deadband delay is programmed using the PWM1CON register (Section 15.5.6).

PIC18F1220/1320

15.5.4 HALF-BRIDGE MODE

In the Half-Bridge Output mode, two pins are used as outputs to drive push-pull loads. The PWM output signal is output on the RB3/CCP1/P1A pin, while the complementary PWM output signal is output on the RB2/P1B/INT2 pin (Figure 15-7). This mode can be used for half-bridge applications, as shown in Figure 15-8, or for full-bridge applications, where four power switches are being modulated with two PWM signals.

In Half-Bridge Output mode, the programmable dead-band delay can be used to prevent shoot-through current in half-bridge power devices. The value of bits PDC6:PDC0 sets the number of instruction cycles before the output is driven active. If the value is greater than the duty cycle, the corresponding output remains inactive during the entire cycle. See Section 15.5.6 for more details of the deadband delay operations.

Since the P1A and P1B outputs are multiplexed with the PORTB<3> and PORTB<2> data latches, the TRISB<3> and TRISB<2> bits must be cleared to configure P1A and P1B as outputs.

FIGURE 15-7: HALF-BRIDGE PWM OUTPUT

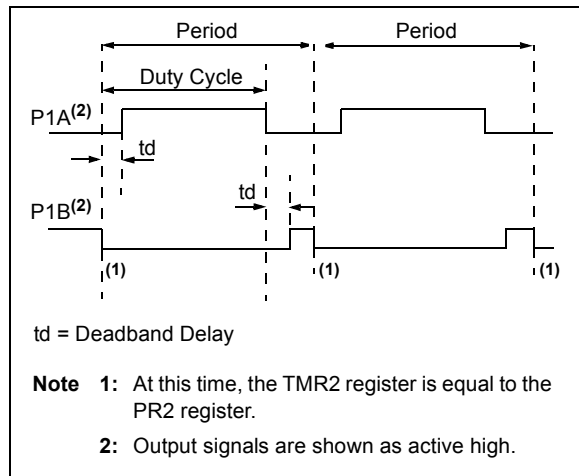
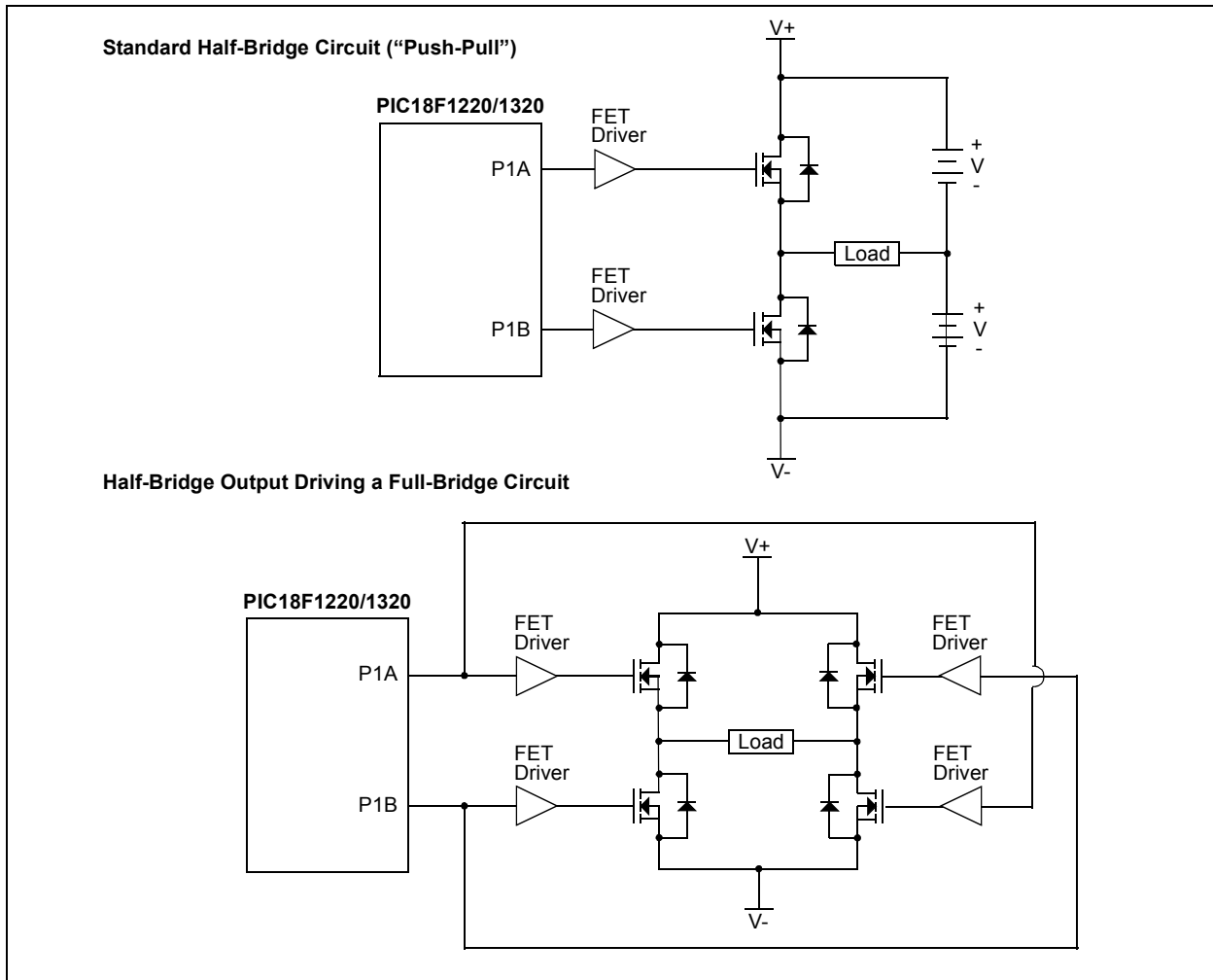

FIGURE 15-8: EXAMPLES OF HALF-BRIDGE OUTPUT MODE APPLICATIONS



15.5.5 FULL-BRIDGE MODE

In Full-Bridge Output mode, four pins are used as outputs; however, only two outputs are active at a time. In the Forward mode, pin RB3/CCP1/P1A is continuously active, and pin RB7/PGD/T1OSI/P1D/KBI3 is modulated. In the Reverse mode, pin RB6/PGC/T1OSO/T1CKI/P1C/KBI2 is continuously active, and pin RB2/P1B/INT2 is modulated. These are illustrated in Figure 15-9.

P1A, P1B, P1C and P1D outputs are multiplexed with the PORTB<3:2> and PORTB<7:6> data latches. The TRISB<3:2> and TRISB<7:6> bits must be cleared to make the P1A, P1B, P1C, and P1D pins output.

FIGURE 15-9: FULL-BRIDGE PWM OUTPUT

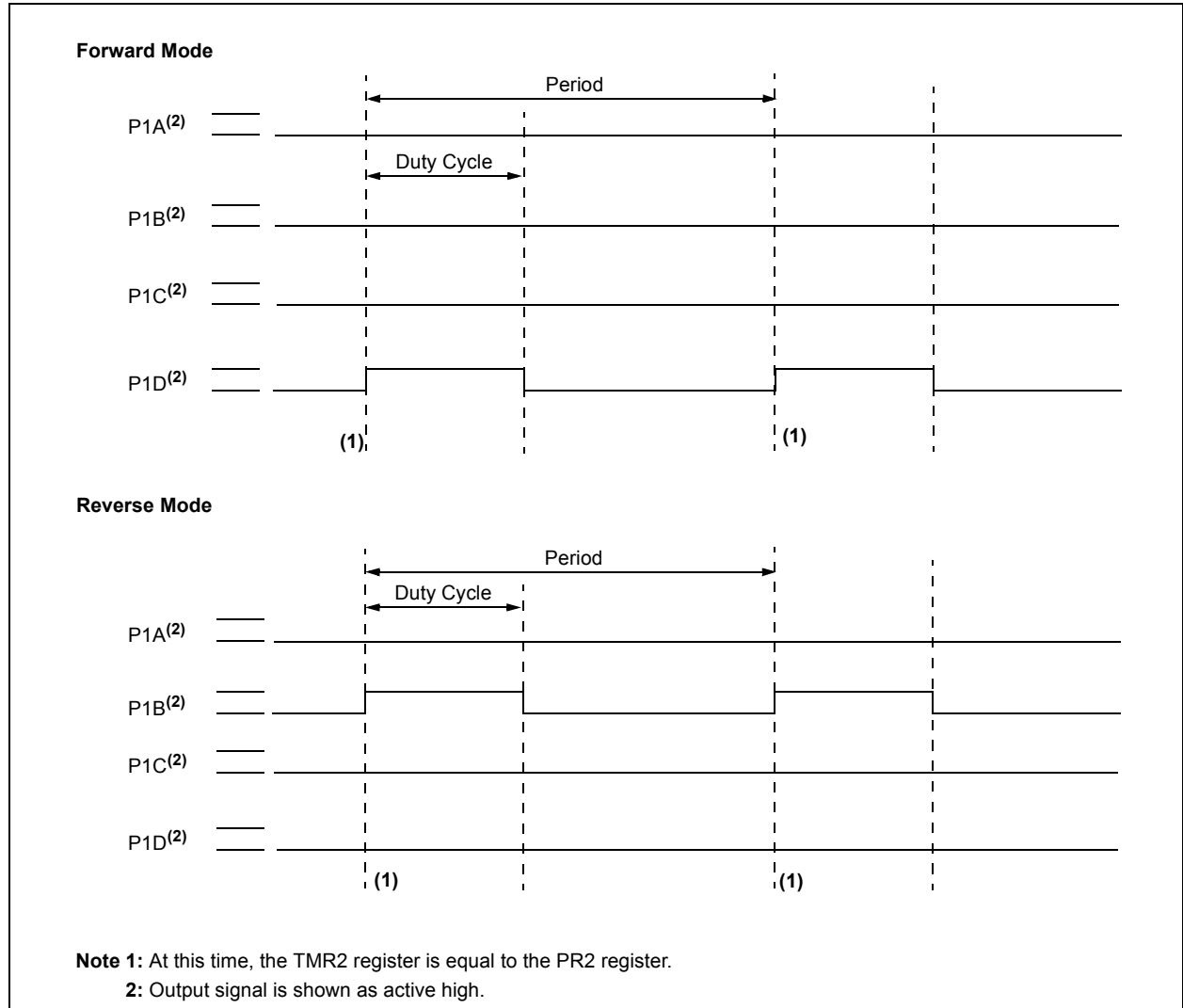

PIC18F1220/1320

FIGURE 15-10: EXAMPLE OF FULL-BRIDGE APPLICATION

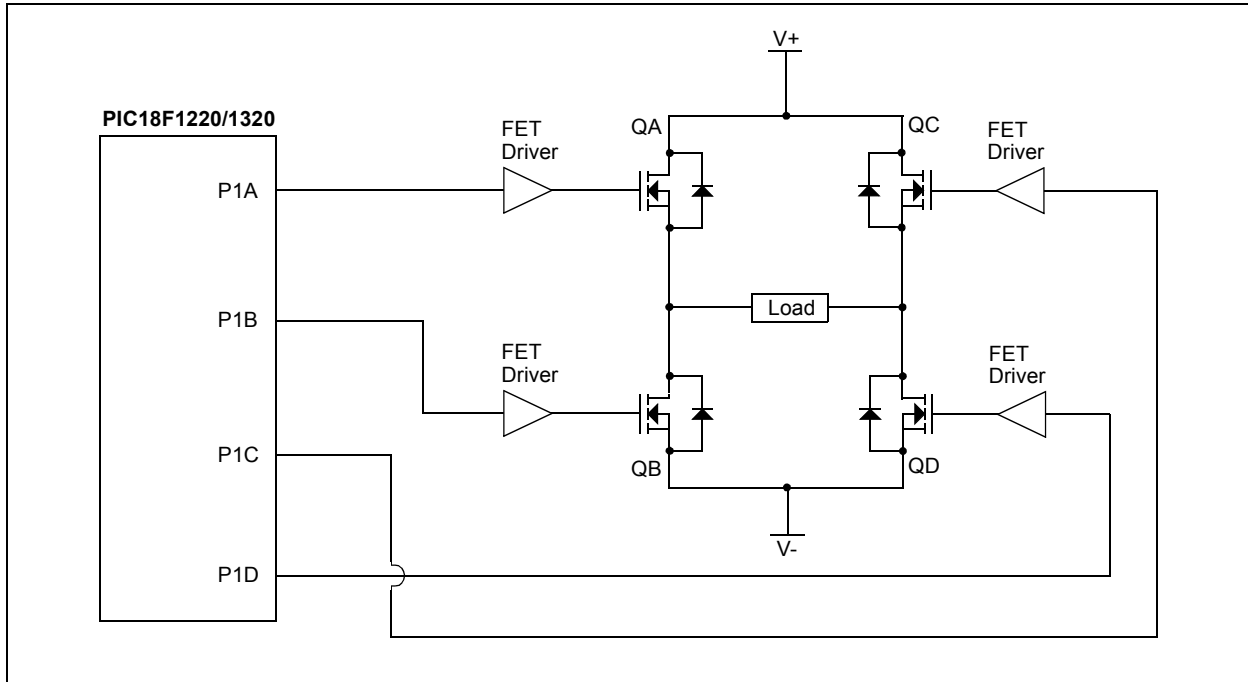

15.5.5.1 Direction Change in Full-Bridge Mode

In the Full-Bridge Output mode, the P1M1 bit in the CCP1CON register allows user to control the Forward/Reverse direction. When the application firmware changes this direction control bit, the module will assume the new direction on the next PWM cycle.

Just before the end of the current PWM period, the modulated outputs (P1B and P1D) are placed in their inactive state, while the unmodulated outputs (P1A and P1C) are switched to drive in the opposite direction. This occurs in a time interval of $(4 T_{OSC} * (\text{Timer2 Prescale value}))$ before the next PWM period begins. The Timer2 prescaler will be either 1, 4 or 16, depending on the value of the T2CKPS bit (T2CON<1:0>). During the interval from the switch of the unmodulated outputs to the beginning of the next period, the modulated outputs (P1B and P1D) remain inactive. This relationship is shown in Figure 15-11.

Note that in the Full-Bridge Output mode, the ECCP module does not provide any deadband delay. In general, since only one output is modulated at all times, deadband delay is not required. However, there is a situation where a deadband delay might be required. This situation occurs when both of the following conditions are true:

1. The direction of the PWM output changes when the duty cycle of the output is at or near 100%.
2. The turn off time of the power switch, including the power device and driver circuit, is greater than the turn on time.

Figure 15-12 shows an example where the PWM direction changes from forward to reverse, at a near 100% duty cycle. At time t_1 , the output P1A and P1D become inactive, while output P1C becomes active. In this example, since the turn off time of the power devices is longer than the turn on time, a shoot-through current may flow through power devices QC and QD (see Figure 15-10) for the duration of 't'. The same phenomenon will occur to power devices QA and QB for PWM direction change from reverse to forward.

If changing PWM direction at high duty cycle is required for an application, one of the following requirements must be met:

1. Reduce PWM for a PWM period before changing directions.
2. Use switch drivers that can drive the switches off faster than they can drive them on.

Other options to prevent shoot-through current may exist.

FIGURE 15-11: PWM DIRECTION CHANGE

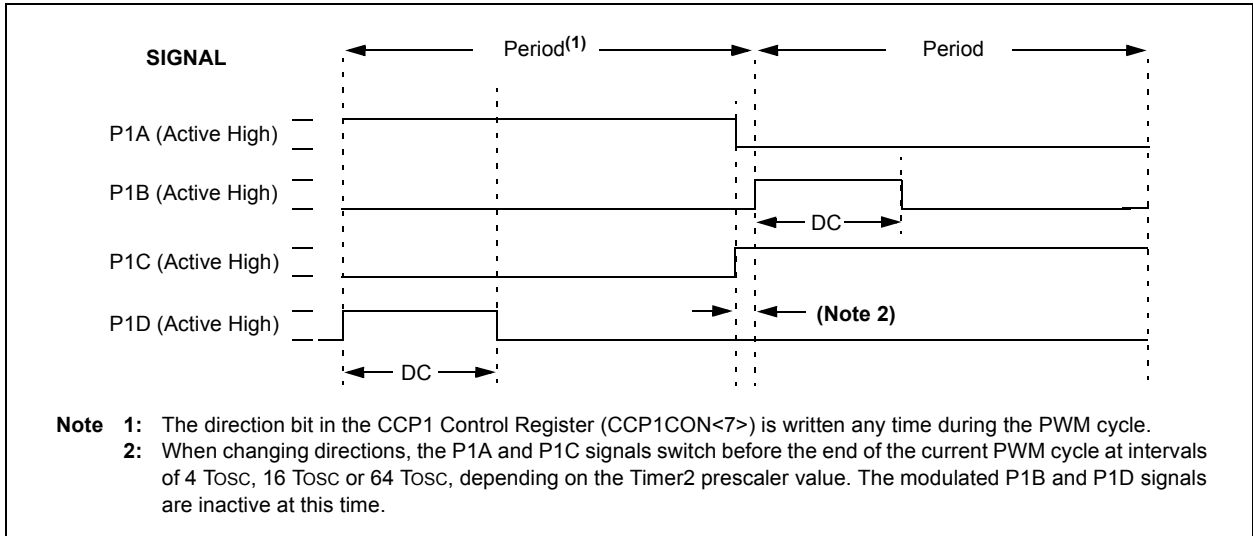
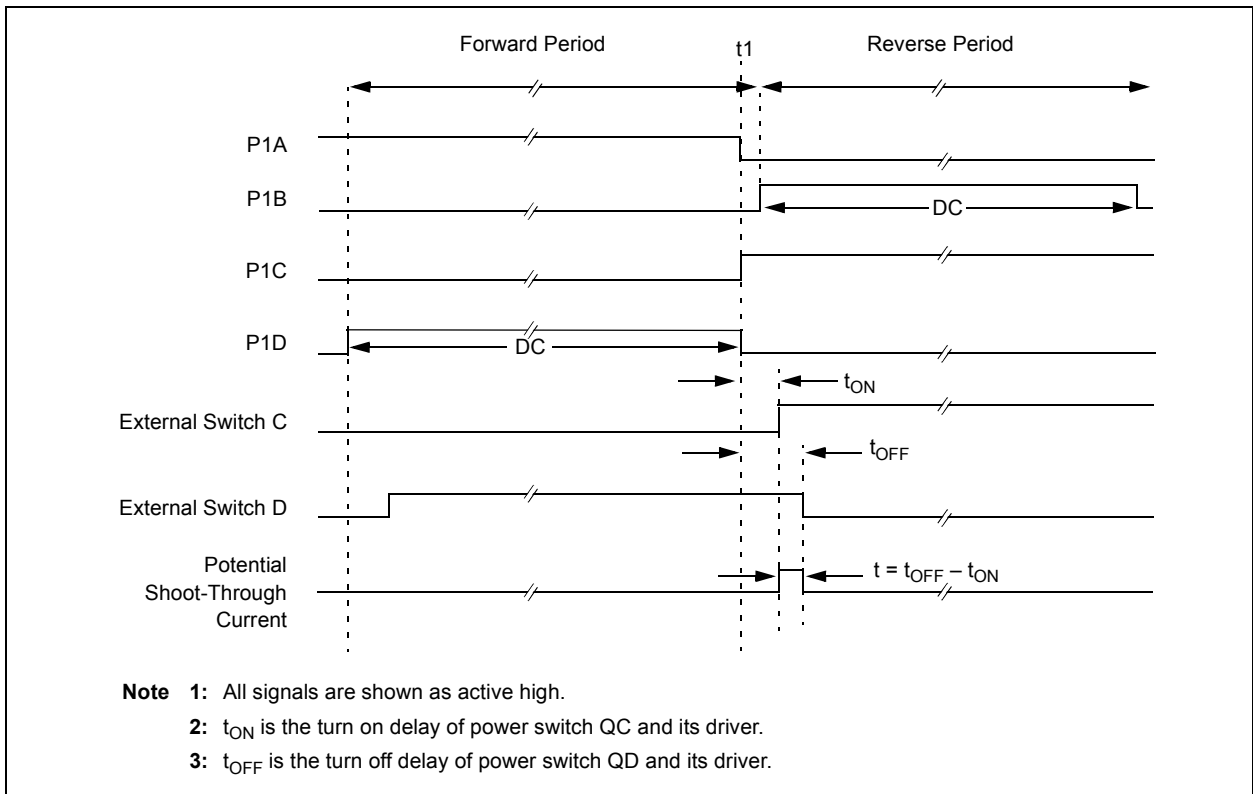

FIGURE 15-12: PWM DIRECTION CHANGE AT NEAR 100% DUTY CYCLE



PIC18F1220/1320

15.5.6 PROGRAMMABLE DEADBAND DELAY

In half-bridge applications where all power switches are modulated at the PWM frequency at all times, the power switches normally require more time to turn off than to turn on. If both the upper and lower power switches are switched at the same time (one turned on, and the other turned off), both switches may be on for a short period of time until one switch completely turns off. During this brief interval, a very high current (*shoot-through current*) may flow through both power switches, shorting the bridge supply. To avoid this potentially destructive shoot-through current from flowing during switching, turning on either of the power switches is normally delayed to allow the other switch to completely turn off.

In the Half-Bridge Output mode, a digitally programmable deadband delay is available to avoid shoot-through current from destroying the bridge power switches. The delay occurs at the signal transition from the non-active state to the active state. See Figure 15-7 for illustration. The lower seven bits of the PWM1CON register (Register 15-2) sets the delay period in terms of microcontroller instruction cycles (Tcy or 4 Tosc).

15.5.7 ENHANCED PWM AUTO SHUTDOWN

When the ECCP is programmed for any of the enhanced PWM modes, the active output pins may be configured for Auto Shutdown. Auto shutdown immediately places the enhanced PWM output pins into a defined shutdown state, when a shutdown event occurs.

A shutdown event can be caused by either of the two comparator modules, or the INT0 pin (or any combination of these three sources). The comparators may be used to monitor a voltage input proportional to a current being monitored in the bridge circuit. If the voltage exceeds a threshold, the comparator switches state and triggers a shutdown. Alternatively, a digital signal on the INT0 pin can also trigger a shutdown. The auto shutdown feature can be disabled by not selecting any auto shutdown sources. The auto shutdown sources to be used are selected using the ECCPAS2:ECCPAS0 bits (bits <6:4> of the ECCPAS register).

When a shutdown occurs, the output pins are asynchronously placed in their shutdown states, specified by the PSSAC1:PSSAC0 and PSSBD1:PSSBD0 bits (ECCPAS<3:0>). Each pin pair (P1A/P1C and P1B/P1D) may be set to drive high, drive low, or be tri-stated (not driving). The ECCPASE bit (ECCPAS<7>) is also set to hold the enhanced PWM outputs in their shutdown states.

The ECCPASE bit is set by hardware when a shutdown event occurs. If automatic restarts are not enabled, the ECCPASE bit is cleared by firmware when the cause of the shutdown clears. If automatic restarts are enabled, the ECCPASE bit is automatically cleared when the cause of the auto shutdown has cleared.

If the ECCPASE bit is set when a PWM period begins, the PWM outputs remain in their shutdown state for that entire PWM period. When the ECCPASE bit is cleared, the PWM outputs will return to normal operation at the beginning of the next PWM period.

Note: Writing to the ECCPASE bit is disabled while a shutdown condition is active.

REGISTER 15-2: PWM1CON: PWM CONFIGURATION REGISTER

R/W-0	R/W-0	R/W-0	R/W-0	R/W-0	R/W-0	R/W-0	R/W-0	
PRSEN	PDC6	PDC5	PDC4	PDC3	PDC2	PDC1	PDC0	
bit 7								bit 0

- bit 7 **PRSEN:** PWM Restart Enable bit
 1 = Upon auto shutdown, the ECCPASE bit clears automatically once the shutdown event goes away; the PWM restarts automatically
 0 = Upon auto shutdown, ECCPASE must be cleared in software to restart the PWM
- bit 6-0 **PDC<6:0>:** PWM Delay Count bits
 Number of Fosc/4 (4*Tosc) cycles between the scheduled time when a PWM signal **should** transition active, and the **actual** time it transitions active.

Legend:

R = Readable bit	W = Writable bit	U = Unimplemented bit, read as '0'
- n = Value at POR	'1' = Bit is set	'0' = Bit is cleared x = Bit is unknown

REGISTER 15-3: ECCPAS: ENHANCED CAPTURE/COMPARE/PWM/AUTO SHUTDOWN CONTROL REGISTER

R/W-0	R/W-0	R/W-0	R/W-0	R/W-0	R/W-0	R/W-0	R/W-0	
ECCPASE	ECCPAS2	ECCPAS1	ECCPAS0	PSSAC1	PSSAC0	PSSBD1	PSSBD0	
bit 7								bit 0

- bit 7 **ECCPASE:** ECCP Auto Shutdown Event Status bit
 0 = ECCP outputs are operating
 1 = A shutdown event has occurred; ECCP outputs are in shutdown state
- bit 6-4 **ECCPAS<2:0>:** ECCP Auto Shutdown Source Select bits
 000 = Auto shutdown is disabled
 001 = Comparator 1 output
 010 = Comparator 2 output
 011 = Either Comparator 1 or 2
 100 = INTO
 101 = INTO or Comparator 1
 110 = INTO or Comparator 2
 111 = INTO or Comparator 1 or Comparator 2
- bit 3-2 **PSSACn:** Pin A and C Shutdown State Control bits
 00 = Drive Pins A and C to '0'
 01 = Drive Pins A and C to '1'
 1x = Pins A and C tri-state
- bit 1-0 **PSSBDn:** Pin B and D Shutdown State Control bits
 00 = Drive Pins B and D to '0'
 01 = Drive Pins B and D to '1'
 1x = Pins B and D tri-state

Legend:			
R = Readable bit	W = Writable bit	U = Unimplemented bit, read as '0'	
- n = Value at POR	'1' = Bit is set	'0' = Bit is cleared	x = Bit is unknown

PIC18F1220/1320

15.5.7.1 Auto Shutdown and Automatic Restart

The auto shutdown feature can be configured to allow automatic restarts of the module, following a shutdown event. This is enabled by setting the PRSEN bit of the PWM1CON register (PWM1CON<7>).

In Shutdown mode with PRSEN = 1 (Figure 15-13), the ECCPASE bit will remain set for as long as the cause of the shutdown continues. When the shutdown condition clears, the ECCPASE bit is cleared. If PRSEN = 0 (Figure 15-14), once a shutdown condition occurs, the ECCPASE bit will remain set until it is cleared by firmware. Once ECCPASE is cleared, the enhanced PWM will resume at the beginning of the next PWM period.

Note: Writing to the ECCPASE bit is disabled while a shutdown condition is active.

Independent of the PRSEN bit setting, if the auto shutdown source is one of the comparators, the shutdown condition is a level. The ECCPASE bit cannot be cleared as long as the cause of the shutdown persists.

The Auto Shutdown mode can be forced by writing a '1' to the ECCPASE bit.

15.5.8 START-UP CONSIDERATIONS

When the ECCP module is used in the PWM mode, the application hardware must use the proper external pull-up and/or pull-down resistors on the PWM output pins. When the microcontroller is released from RESET, all of the I/O pins are in the high-impedance state. The external circuits must keep the power switch devices in the off state, until the microcontroller drives the I/O pins with the proper signal levels, or activates the PWM output(s).

The CCP1M1:CCP1M0 bits (CCP1CON<1:0>) allow the user to choose whether the PWM output signals are active high or active low for each pair of PWM output pins (P1A/P1C and P1B/P1D). The PWM output polarities must be selected before the PWM pins are configured as outputs. Changing the polarity configuration while the PWM pins are configured as outputs is not recommended, since it may result in damage to the application circuits.

The P1A, P1B, P1C and P1D output latches may not be in the proper states when the PWM module is initialized. Enabling the PWM pins for output at the same time as the ECCP module may cause damage to the application circuit. The ECCP module must be enabled in the proper Output mode and complete a full PWM cycle, before configuring the PWM pins as outputs. The completion of a full PWM cycle is indicated by the TMR2IF bit being set as the second PWM period begins.

FIGURE 15-13: PWM AUTO SHUTDOWN (PRSEN = 1, AUTO RESTART ENABLED)

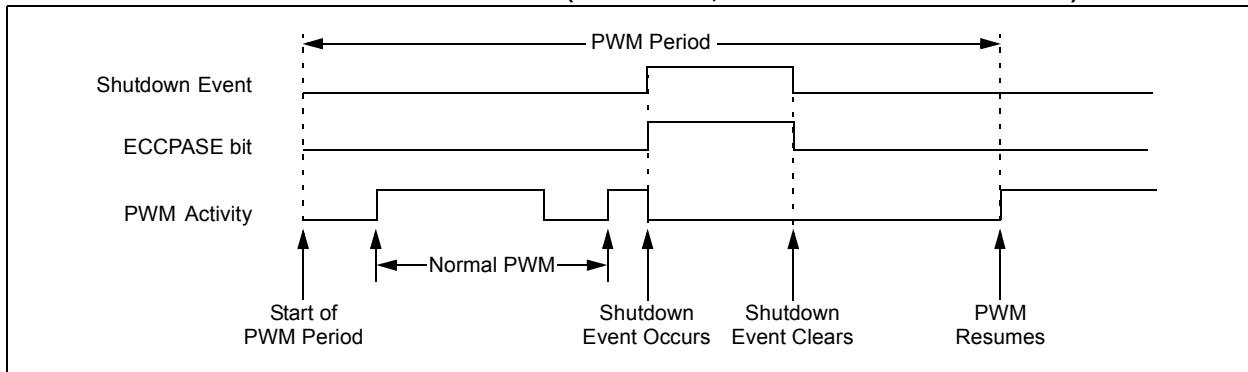
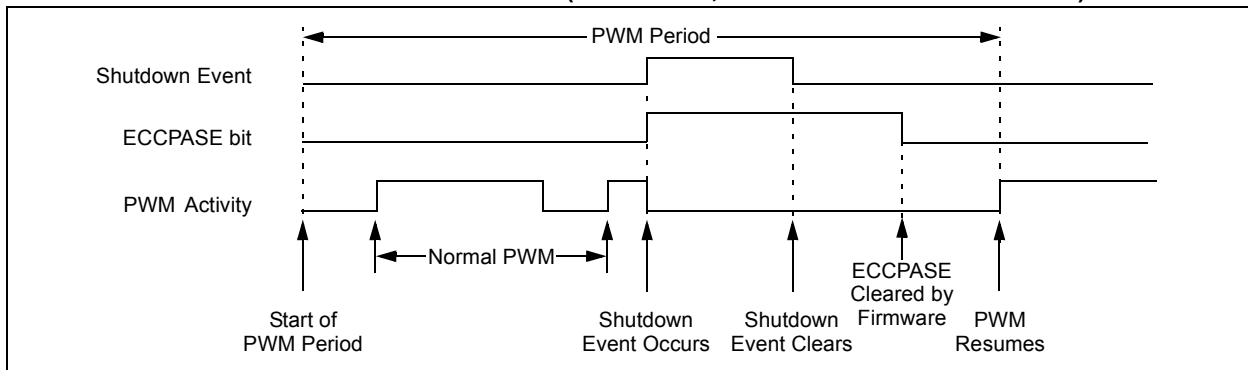

FIGURE 15-14: PWM AUTO SHUTDOWN (PRSEN = 0, AUTO RESTART DISABLED)



15.5.9 SETUP FOR PWM OPERATION

The following steps should be taken when configuring the ECCP1 module for PWM operation:

1. Configure the PWM pins P1A and P1B (and P1C and P1D, if used) as inputs by setting the corresponding TRISB bits.
2. Set the PWM period by loading the PR2 register.
3. Configure the ECCP module for the desired PWM mode and configuration by loading the CCP1CON register with the appropriate values:
 - Select one of the available output configurations and direction with the P1M1:P1M0 bits.
 - Select the polarities of the PWM output signals with the CCP1M3:CCP1M0 bits.
4. Set the PWM duty cycle by loading the CCPR1L register and CCP1CON<5:4> bits.
5. For Half-Bridge Output mode, set the deadband delay by loading PWM1CON<6:0> with the appropriate value.
6. If auto shutdown operation is required, load the ECCPAS register:
 - Select the auto shutdown sources using the ECCPAS<2:0> bits.
 - Select the shutdown states of the PWM output pins using PSSAC1:PSSAC0 and PSSBD1:PSSBD0 bits.
 - Set the ECCPASE bit (ECCPAS<7>).
 - Configure the comparators using the CMCON register.
 - Configure the comparator inputs as analog inputs.
7. If auto restart operation is required, set the PRSEN bit (PWM1CON<7>).
8. Configure and start TMR2:
 - Clear the TMR2 interrupt flag bit by clearing the TMR2IF bit (PIR1<1>).
 - Set the TMR2 prescale value by loading the T2CKPS bits (T2CON<1:0>).
 - Enable Timer2 by setting the TMR2ON bit (T2CON<2>).
9. Enable PWM outputs after a new PWM cycle has started:
 - Wait until TMR2 overflows (TMR2IF bit is set).
 - Enable the CCP1/P1A, P1B, P1C and/or P1D pin outputs by clearing the respective TRISB bits.
 - Clear the ECCPASE bit (ECCPAS<7>).

15.5.10 OPERATION IN LOW POWER MODES

In the low power SLEEP mode, all clock sources are disabled. Timer2 will not increment and the state of the module will not change. If the ECCP pin is driving a value, it will continue to drive that value. When the device wakes up, it will continue from this state. If Two-Speed Start-ups are enabled, the initial start-up frequency may not be stable if the INTOSC is being used.

In PRI_IDLE mode, the primary clock will continue to clock the ECCP module without change.

In all other Low Power modes, the selected Low Power mode clock will clock Timer2. Other Low Power mode clocks will most likely be different than the primary clock frequency.

15.5.10.1 Operation with Fail-Safe Clock Monitor

If the Fail-Safe Clock Monitor is enabled (CONFIG1H<6> is programmed), a clock failure will force the device into the RC_RUN Low Power mode, and the OSCFIF bit (PIR2<7>) will be set. The ECCP will then be clocked from the INTRC clock source, which may have a different clock frequency than the primary clock. By loading the IRCF2:IRCF0 on RESETS, the user can enable the INTOSC at a high clock speed in the event of a clock failure.

See the previous section for additional details.

15.5.11 EFFECTS OF A RESET

Both power-on and subsequent RESETS will force all ports to Input mode and the CCP registers to their RESET states.

This forces the Enhanced CCP module to reset to a state compatible with the standard CCP module.

PIC18F1220/1320

TABLE 15-4: REGISTERS ASSOCIATED WITH ENHANCED PWM AND TIMER2

Name	Bit 7	Bit 6	Bit 5	Bit 4	Bit 3	Bit 2	Bit 1	Bit 0	Value on POR, BOR	Value on all other RESETS
INTCON	GIE/GIEH	PEIE/GIEL	TMR0IE	INT0IE	RBIE	TMR0IF	INT0IF	RBIF	0000 000x	0000 000u
RCON	IPEN	—	—	\overline{RI}	\overline{TO}	\overline{PD}	\overline{POR}	\overline{BOR}	0--1 11qq	0--q qquu
PIR1	—	ADIF	RCIF	TXIF	—	CCP1IF	TMR2IF	TMR1IF	-000 -000	-000 -000
PIE1	—	ADIE	RCIE	TXIE	—	CCP1IE	TMR2IE	TMR1IE	-000 -000	-000 -000
IPR1	—	ADIP	RCIP	TXIP	—	CCP1IP	TMR2IP	TMR1IP	-111 -111	-111 -111
TMR2	Timer2 Module Register								0000 0000	0000 0000
PR2	Timer2 Module Period Register								1111 1111	1111 1111
T2CON	—	TOUTPS3	TOUTPS2	TOUTPS1	TOUTPS0	TMR2ON	T2CKPS1	T2CKPS0	-000 0000	-000 0000
TRISB	PORTB Data Direction Register								1111 1111	1111 1111
CCPR1H	Enhanced Capture/Compare/PWM Register1 High Byte								xxxx xxxx	uuuu uuuu
CCPR1L	Enhanced Capture/Compare/PWM Register1 Low Byte								xxxx xxxx	uuuu uuuu
CCP1CON	P1M1	P1M0	DC1B1	DC1B0	CCP1M3	CCP1M2	CCP1M1	CCP1M0	0000 0000	0000 0000
ECCPAS	ECCPASE	ECCPAS2	ECCPAS1	ECCPAS0	PSSAC1	PSSAC0	PSSBD1	PSSBD0	0000 0000	0000 0000
PWM1CON	PRSEN	PDC6	PDC5	PDC4	PDC3	PDC2	PDC1	PDC0	0000 0000	uuuu uuuu
OSCCON	IDLEN	IRCF2	IRCF1	IRCF0	OSTS	FLTS	SCS1	SCS0	0000 q000	uuuu uuqu

Legend: x = unknown, u = unchanged, - = unimplemented, read as '0'.

Shaded cells are not used by the ECCP module in enhanced PWM mode.

16.0 ENHANCED UNIVERSAL SYNCHRONOUS ASYNCHRONOUS RECEIVER TRANSMITTER (USART)

The Universal Synchronous Asynchronous Receiver Transmitter (USART) module is one of the two serial I/O modules. (USART is also known as a Serial Communications Interface or SCI.) The USART can be configured as a full-duplex asynchronous system that can communicate with peripheral devices, such as CRT terminals and personal computers. It can also be configured as a half-duplex synchronous system that can communicate with peripheral devices, such as A/D or D/A integrated circuits, serial EEPROMs, etc.

The Enhanced USART module implements additional features, including automatic baud rate detection and calibration, automatic wake-up on Sync Break reception and 12-bit Break character transmit. These make it ideally suited for use in Local Interconnect Network bus (LIN bus) systems.

The USART can be configured in the following modes:

- Asynchronous (full-duplex) with:
 - Auto wake-up on character reception
 - Auto baud calibration
 - 12-bit Break character transmission
- Synchronous - Master (half-duplex) with selectable clock polarity
- Synchronous - Slave (half-duplex) with selectable clock polarity

In order to configure pins RB1/AN5/TX/CK/INT1 and RB4/AN6/RX/DT as the Universal Synchronous Asynchronous Receiver Transmitter:

- SPEN (RCSTA<7>) bit must be set (= 1),
- PCFG6:PCFG5 (ADCON1<5:6>) must be set (= 1),
- TRISB<4> bit must be set (= 1), and
- TRISB<1> bit must be set (= 1).

Note: The USART control will automatically reconfigure the pin from input to output as needed.

The operation of the Enhanced USART module is controlled through three registers:

- Transmit Status and Control (TXSTA)
- Receive Status and Control (RCSTA)
- Baud Rate Control (BAUDCTL)

These are detailed in on the following pages in Register 16-1, Register 16-2 and Register 16-3, respectively.

16.1 Asynchronous Operation in Power Managed Modes

The USART may operate in Asynchronous mode while the peripheral clocks are being provided by the internal oscillator block. This makes it possible to remove the crystal or resonator that is commonly connected as the primary clock on the OSC1 and OSC2 pins.

The factory calibrates the internal oscillator block output (INTOSC) for 8 MHz (see Table 22.5). However, this frequency may drift as V_{DD} or temperature changes, and this directly affects the asynchronous baud rate. Two methods may be used to adjust the baud rate clock, but both require a reference clock source of some kind.

The first (preferred) method uses the OSCTUNE register to adjust the INTOSC output back to 8 MHz. Adjusting the value in the OSCTUNE register allows for fine resolution changes to the system clock source (see Section 3.6 for more information).

The other method adjusts the value in the baud rate generator. There may not be fine enough resolution when adjusting the Baud Rate Generator to compensate for a gradual change in the peripheral clock frequency.

PIC18F1220/1320

REGISTER 16-1: TXSTA: TRANSMIT STATUS AND CONTROL REGISTER

R/W-0	R/W-0	R/W-0	R/W-0	U-0	R/W-0	R-1	R/W-0
CSRC	TX9	TXEN	SYNC	SENDB	BRGH	TRMT	TX9D

bit 7

bit 0

bit 7 **CSRC:** Clock Source Select bit

Asynchronous mode:

Don't care

Synchronous mode:

1 = Master mode (clock generated internally from BRG)

0 = Slave mode (clock from external source)

bit 6 **TX9:** 9-bit Transmit Enable bit

1 = Selects 9-bit transmission

0 = Selects 8-bit transmission

bit 5 **TXEN:** Transmit Enable bit

1 = Transmit enabled

0 = Transmit disabled

Note: SREN/CREN overrides TXEN in Sync mode.

bit 4 **SYNC:** USART Mode Select bit

1 = Synchronous mode

0 = Asynchronous mode

bit 3 **SENDB:** Send Break Character bit

Asynchronous mode:

1 = Send Sync Break on next transmission (cleared by hardware upon completion)

0 = Sync Break transmission completed

Synchronous mode:

Don't care

bit 2 **BRGH:** High Baud Rate Select bit

Asynchronous mode:

1 = High speed

0 = Low speed

Synchronous mode:

Unused in this mode

bit 1 **TRMT:** Transmit Shift Register Status bit

1 = TSR empty

0 = TSR full

bit 0 **TX9D:** 9th bit of Transmit Data

Can be address/data bit or a parity bit.

Legend:

R = Readable bit

W = Writable bit

U = Unimplemented bit, read as '0'

- n = Value at POR

'1' = Bit is set

'0' = Bit is cleared

x = Bit is unknown

REGISTER 16-2: RCSTA: RECEIVE STATUS AND CONTROL REGISTER

R/W-0	R/W-0	R/W-0	R/W-0	R/W-0	R-0	R-0	R-x
SPEN	RX9	SREN	CREN	ADDEN	FERR	OERR	RX9D
bit 7							bit 0

- bit 7 **SPEN:** Serial Port Enable bit
 1 = Serial port enabled (configures RX/DT and TX/CK pins as serial port pins)
 0 = Serial port disabled (held in RESET)
- bit 6 **RX9:** 9-bit Receive Enable bit
 1 = Selects 9-bit reception
 0 = Selects 8-bit reception
- bit 5 **SREN:** Single Receive Enable bit
Asynchronous mode:
 Don't care
Synchronous mode - Master:
 1 = Enables single receive
 0 = Disables single receive
 This bit is cleared after reception is complete.
Synchronous mode - Slave:
 Don't care
- bit 4 **CREN:** Continuous Receive Enable bit
Asynchronous mode:
 1 = Enables receiver
 0 = Disables receiver
Synchronous mode:
 1 = Enables continuous receive until enable bit CREN is cleared (CREN overrides SREN)
 0 = Disables continuous receive
- bit 3 **ADDEN:** Address Detect Enable bit
Asynchronous mode 9-bit (RX9 = 1):
 1 = Enables address detection, enable interrupt and load the receive buffer when RSR<8> is set
 0 = Disables address detection, all bytes are received and ninth bit can be used as parity bit
Asynchronous mode 9-bit (RX9 = 0):
 Don't care
- bit 2 **FERR:** Framing Error bit
 1 = Framing error (can be updated by reading RCREG register and receive next valid byte)
 0 = No framing error
- bit 1 **OERR:** Overrun Error bit
 1 = Overrun error (can be cleared by clearing bit CREN)
 0 = No overrun error
- bit 0 **RX9D:** 9th bit of Received Data
 This can be address/data bit or a parity bit and must be calculated by user firmware.

Legend:

R = Readable bit	W = Writable bit	U = Unimplemented bit, read as '0'
- n = Value at POR	'1' = Bit is set	'0' = Bit is cleared x = Bit is unknown

PIC18F1220/1320

REGISTER 16-3: BAUDCTL: BAUD RATE CONTROL REGISTER

U-0	R-1	U-0	R/W-0	R/W-0	U-0	R/W-0	R/W-0
—	RCIDL	—	SCKP	BRG16	—	WUE	ABDEN
bit 7							bit 0

bit 7	Unimplemented: Read as '0'
bit 6	RCIDL: Receive Operation IDLE Status bit 1 = Receive operation is IDLE 0 = Receive operation is active
bit 5	Unimplemented: Read as '0'
bit 4	SCKP: Synchronous Clock Polarity Select bit <u>Asynchronous mode:</u> Unused in this mode <u>Synchronous mode:</u> 1 = IDLE state for clock (CK) is a high level 0 = IDLE state for clock (CK) is a low level
bit 3	BRG16: 16-bit Baud Rate Register Enable bit 1 = 16-bit baud rate generator - SPBRGH and SPBRG 0 = 8-bit baud rate generator - SPBRG only (Compatible mode), SPBRGH value ignored
bit 2	Unimplemented: Read as '0'
bit 1	WUE: Wake-up Enable bit <u>Asynchronous mode:</u> 1 = USART will continue to sample the RX pin - interrupt generated on falling edge; bit cleared in hardware on following rising edge 0 = RX pin not monitored or rising edge detected <u>Synchronous mode:</u> Unused in this mode
bit 0	ABDEN: Auto Baud Detect Enable bit <u>Asynchronous mode:</u> 1 = Enable baud rate measurement on the next character - requires reception of a Sync field (55h); cleared in hardware upon completion 0 = Baud rate measurement disabled or completed <u>Synchronous mode:</u> Unused in this mode

Legend:			
R = Readable bit	W = Writable bit	U = Unimplemented bit, read as '0'	
- n = Value at POR	'1' = Bit is set	'0' = Bit is cleared	x = Bit is unknown

16.2 USART Baud Rate Generator (BRG)

The BRG is a dedicated 8-bit or 16-bit generator, that supports both the Asynchronous and Synchronous modes of the USART. By default, the BRG operates in 8-bit mode; setting the BRG16 bit (BAUDCTL<3>) selects 16-bit mode.

The SPBRGH:SPBRG register pair controls the period of a free running timer. In Asynchronous mode, bits BRGH (TXSTA<2>) and BRG16 also control the baud rate. In Synchronous mode, bit BRGH is ignored. Table 16-1 shows the formula for computation of the baud rate for different USART modes, which only apply in Master mode (internally generated clock).

Given the desired baud rate and FOSC, the nearest integer value for the SPBRGH:SPBRG registers can be calculated using the formulas in Table 16-1. From this, the error in baud rate can be determined. An example calculation is shown in Example 16-1. Typical baud rates and error values for the various asynchronous modes are shown in Table 16-2. It may be advantageous to use the high baud rate (BRGH = 1), or the 16-bit BRG to reduce the baud rate error, or achieve a slow baud rate for a fast oscillator frequency.

Writing a new value to the SPBRGH:SPBRG registers causes the BRG timer to be reset (or cleared). This ensures the BRG does not wait for a timer overflow before outputting the new baud rate.

16.2.1 POWER MANAGED MODE OPERATION

The system clock is used to generate the desired baud rate; however, when a Power Managed mode is entered, the clock source may be operating at a different frequency than in PRI_RUN mode. In SLEEP mode, no clocks are present and in PRI_IDLE, the primary clock source continues to provide clocks to the baud rate generator; however, in other Power Managed modes, the clock frequency will probably change. This may require the value in SPBRG to be adjusted.

If the system clock is changed during an active receive operation, a receive error or data loss may result. To avoid this problem, check the status of the RCIDL bit and make sure that the receive operation is IDLE before changing the system clock.

16.2.2 SAMPLING

The data on the RB4/RX/DT pin is sampled three times by a majority detect circuit to determine if a high or a low level is present at the RX pin.

TABLE 16-1: BAUD RATE FORMULAS

Configuration Bits			BRG/USART Mode	Baud Rate Formula
SYNC	BRG16	BRGH		
0	0	0	8-bit/Asynchronous	$F_{OSC} / [64 (n+1)]$
0	0	1	8-bit/Asynchronous	$F_{OSC} / [16 (n+1)]$
0	1	0	16-bit/Asynchronous	
0	1	1	16-bit/Asynchronous	$F_{OSC} / [4 (n+1)]$
1	0	x	8-bit/Synchronous	
1	1	x	16-bit/Synchronous	

Legend: x = Don't care, n = value of SPBRGH:SPBRG register pair

PIC18F1220/1320

EXAMPLE 16-1: CALCULATING BAUD RATE ERROR

For a device with FOSC of 16 MHz, desired baud rate of 9600, Asynchronous mode, 8-bit BRG:

$$\text{Desired Baud Rate} = \text{Fosc} / (64 ([\text{SPBRGH}:\text{SPBRG}] + 1))$$

Solving for SPBRGH:SPBRG:

$$\begin{aligned} X &= ((\text{Fosc} / \text{Desired Baud Rate})/64) - 1 \\ &= ((16000000 / 9600) / 64) - 1 \\ &= [25.042] = 25 \end{aligned}$$

$$\begin{aligned} \text{Calculated Baud Rate} &= 16000000 / (64 (25 + 1)) \\ &= 9615 \end{aligned}$$

$$\begin{aligned} \text{Error} &= (\text{Calculated Baud Rate} - \text{Desired Baud Rate}) / \text{Desired Baud Rate} \\ &= (9615 - 9600) / 9600 = 0.16\% \end{aligned}$$

TABLE 16-2: REGISTERS ASSOCIATED WITH BAUD RATE GENERATOR

Name	Bit 7	Bit 6	Bit 5	Bit 4	Bit 3	Bit 2	Bit 1	Bit 0	Value on POR, BOR	Value on all other RESETS
TXSTA	CSRC	TX9	TXEN	SYNC	SENDB	BRGH	TRMT	TX9D	0000 -010	0000 -010
RCSTA	SPEN	RX9	SREN	CREN	ADDEN	FERR	OERR	RX9D	0000 -00x	0000 -00x
BAUDCTL	—	RCIDL	—	SCKP	BRG16	—	WUE	ABDEN	-1-1 0-00	-1-1 0-00
SPBRGH	Baud Rate Generator Register, High Byte								0000 0000	0000 0000
SPBRG	Baud Rate Generator Register, Low Byte								0000 0000	0000 0000

Legend: x = unknown, - = unimplemented, read as '0'. Shaded cells are not used by the BRG.

TABLE 16-3: BAUD RATES FOR ASYNCHRONOUS MODES

BAUD RATE (K)	SYNC = 0, BRGH = 0, BRG16 = 0											
	Fosc = 40.000 MHz			Fosc = 20.000 MHz			Fosc = 10.000 MHz			Fosc = 8.000 MHz		
	Actual Rate (K)	% Error	SPBRG value (decimal)	Actual Rate (K)	% Error	SPBRG value (decimal)	Actual Rate (K)	% Error	SPBRG value (decimal)	Actual Rate (K)	% Error	SPBRG value (decimal)
0.3	—	—	—	—	—	—	—	—	—	—	—	—
1.2	—	—	—	1.221	1.73	255	1.202	0.16	129	1201	-0.16	103
2.4	2.441	1.73	255	2.404	0.16	129	2.404	0.16	64	2403	-0.16	51
9.6	9.615	0.16	64	9.766	1.73	31	9.766	1.73	15	9615	-0.16	12
19.2	19.531	1.73	31	19.531	1.73	15	19.531	1.73	7	—	—	—
57.6	56.818	-1.36	10	62.500	8.51	4	52.083	-9.58	2	—	—	—
115.2	125.000	8.51	4	104.167	-9.58	2	78.125	-32.18	1	—	—	—

BAUD RATE (K)	SYNC = 0, BRGH = 0, BRG16 = 0								
	Fosc = 4.000 MHz			Fosc = 2.000 MHz			Fosc = 1.000 MHz		
	Actual Rate (K)	% Error	SPBRG value (decimal)	Actual Rate (K)	% Error	SPBRG value (decimal)	Actual Rate (K)	% Error	SPBRG value (decimal)
0.3	0.300	0.16	207	300	-0.16	103	300	-0.16	51
1.2	1.202	0.16	51	1201	-0.16	25	1201	-0.16	12
2.4	2.404	0.16	25	2403	-0.16	12	—	—	—
9.6	8.929	-6.99	6	—	—	—	—	—	—
19.2	20.833	8.51	2	—	—	—	—	—	—
57.6	62.500	8.51	0	—	—	—	—	—	—
115.2	62.500	-45.75	0	—	—	—	—	—	—

TABLE 16-3: BAUD RATES FOR ASYNCHRONOUS MODES (CONTINUED)

BAUD RATE (K)	SYNC = 0, BRGH = 1, BRG16 = 0											
	Fosc = 40.000 MHz			Fosc = 20.000 MHz			Fosc = 10.000 MHz			Fosc = 8.000 MHz		
	Actual Rate (K)	% Error	SPBRG value (decimal)	Actual Rate (K)	% Error	SPBRG value (decimal)	Actual Rate (K)	% Error	SPBRG value (decimal)	Actual Rate (K)	% Error	SPBRG value (decimal)
2.4	—	—	—	—	—	—	2.441	1.73	255	2403	-0.16	207
9.6	9.766	1.73	255	9.615	0.16	129	9.615	0.16	64	9615	-0.16	51
19.2	19.231	0.16	129	19.231	0.16	64	19.531	1.73	31	19230	-0.16	25
57.6	58.140	0.94	42	56.818	-1.36	21	56.818	-1.36	10	55555	3.55	8
115.2	113.636	-1.36	21	113.636	-1.36	10	125.000	8.51	4	—	—	—

BAUD RATE (K)	SYNC = 0, BRGH = 1, BRG16 = 0								
	Fosc = 4.000 MHz			Fosc = 2.000 MHz			Fosc = 1.000 MHz		
	Actual Rate (K)	% Error	SPBRG value (decimal)	Actual Rate (K)	% Error	SPBRG value (decimal)	Actual Rate (K)	% Error	SPBRG value (decimal)
0.3	—	—	—	—	—	—	300	-0.16	207
1.2	1.202	0.16	207	1201	-0.16	103	1201	-0.16	51
2.4	2.404	0.16	103	2403	-0.16	51	2403	-0.16	25
9.6	9.615	0.16	25	9615	-0.16	12	—	—	—
19.2	19.231	0.16	12	—	—	—	—	—	—
57.6	62.500	8.51	3	—	—	—	—	—	—
115.2	125.000	8.51	1	—	—	—	—	—	—

BAUD RATE (K)	SYNC = 0, BRGH = 0, BRG16 = 1											
	Fosc = 40.000 MHz			Fosc = 20.000 MHz			Fosc = 10.000 MHz			Fosc = 8.000 MHz		
	Actual Rate (K)	% Error	SPBRG value (decimal)	Actual Rate (K)	% Error	SPBRG value (decimal)	Actual Rate (K)	% Error	SPBRG value (decimal)	Actual Rate (K)	% Error	SPBRG value (decimal)
0.3	0.300	0.00	8332	0.300	0.02	4165	0.300	0.02	2082	300	-0.04	1665
1.2	1.200	0.02	2082	1.200	-0.03	1041	1.200	-0.03	520	1201	-0.16	415
2.4	2.402	0.06	1040	2.399	-0.03	520	2.404	0.16	259	2403	-0.16	207
9.6	9.615	0.16	259	9.615	0.16	129	9.615	0.16	64	9615	-0.16	51
19.2	19.231	0.16	129	19.231	0.16	64	19.531	1.73	31	19230	-0.16	25
57.6	58.140	0.94	42	56.818	-1.36	21	56.818	-1.36	10	55555	3.55	8
115.2	113.636	-1.36	21	113.636	-1.36	10	125.000	8.51	4	—	—	—

BAUD RATE (K)	SYNC = 0, BRGH = 0, BRG16 = 1								
	Fosc = 4.000 MHz			Fosc = 2.000 MHz			Fosc = 1.000 MHz		
	Actual Rate (K)	% Error	SPBRG value (decimal)	Actual Rate (K)	% Error	SPBRG value (decimal)	Actual Rate (K)	% Error	SPBRG value (decimal)
0.3	0.300	0.04	832	300	-0.16	415	300	-0.16	207
1.2	1.202	0.16	207	1201	-0.16	103	1201	-0.16	51
2.4	2.404	0.16	103	2403	-0.16	51	2403	-0.16	25
9.6	9.615	0.16	25	9615	-0.16	12	—	—	—
19.2	19.231	0.16	12	—	—	—	—	—	—
57.6	62.500	8.51	3	—	—	—	—	—	—
115.2	125.000	8.51	1	—	—	—	—	—	—

PIC18F1220/1320

TABLE 16-3: BAUD RATES FOR ASYNCHRONOUS MODES (CONTINUED)

BAUD RATE (K)	SYNC = 0, BRGH = 1, BRG16 = 1 or SYNC = 1, BRG16 = 1											
	Fosc = 40.000 MHz			Fosc = 20.000 MHz			Fosc = 10.000 MHz			Fosc = 8.000 MHz		
	Actual Rate (K)	% Error	SPBRG value (decimal)	Actual Rate (K)	% Error	SPBRG value (decimal)	Actual Rate (K)	% Error	SPBRG value (decimal)	Actual Rate (K)	% Error	SPBRG value (decimal)
0.3	0.300	0.00	33332	0.300	0.00	16665	0.300	0.00	8332	300	-0.01	6665
1.2	1.200	0.00	8332	1.200	0.02	4165	1.200	0.02	2082	1200	-0.04	1665
2.4	2.400	0.02	4165	2.400	0.02	2082	2.402	0.06	1040	2400	-0.04	832
9.6	9.606	0.06	1040	9.596	-0.03	520	9.615	0.16	259	9615	-0.16	207
19.2	19.193	-0.03	520	19.231	0.16	259	19.231	0.16	129	19230	-0.16	103
57.6	57.803	0.35	172	57.471	-0.22	86	58.140	0.94	42	57142	0.79	34
115.2	114.943	-0.22	86	116.279	0.94	42	113.636	-1.36	21	117647	-2.12	16

BAUD RATE (K)	SYNC = 0, BRGH = 1, BRG16 = 1 or SYNC = 1, BRG16 = 1								
	Fosc = 4.000 MHz			Fosc = 2.000 MHz			Fosc = 1.000 MHz		
	Actual Rate (K)	% Error	SPBRG value (decimal)	Actual Rate (K)	% Error	SPBRG value (decimal)	Actual Rate (K)	% Error	SPBRG value (decimal)
0.3	0.300	0.01	3332	300	-0.04	1665	300	-0.04	832
1.2	1.200	0.04	832	1201	-0.16	415	1201	-0.16	207
2.4	2.404	0.16	415	2403	-0.16	207	2403	-0.16	103
9.6	9.615	0.16	103	9615	-0.16	51	9615	-0.16	25
19.2	19.231	0.16	51	19230	-0.16	25	19230	-0.16	12
57.6	58.824	2.12	16	55555	3.55	8	—	—	—
115.2	111.111	-3.55	8	—	—	—	—	—	—

16.2.3 AUTO BAUD RATE DETECT

The Enhanced USART module supports the automatic detection and calibration of baud rate. This feature is active only in Asynchronous mode and while the WUE bit is clear.

The automatic baud rate measurement sequence (Figure 16-1) begins whenever a START bit is received and the ABDEN bit is set. The calculation is self-averaging.

In the Auto Baud Rate Detect (ABD) mode, the clock to the BRG is reversed. Rather than the BRG clocking the incoming RX signal, the RX signal is timing the BRG. In ABD mode, the internal Baud Rate Generator is used as a counter to time the bit period of the incoming serial byte stream.

Once the ABDEN bit is set, the state machine will clear the BRG and look for a START bit. The Auto Baud Detect must receive a byte with the value 55h (ASCII "U", which is also the LIN bus Sync character), in order to calculate the proper bit rate. The measurement is taken over both a low and a high bit time in order to minimize any effects caused by asymmetry of the incoming signal. After a START bit, the SPBRG begins counting up using the preselected clock source on the first rising edge of RX. After eight bits on the RX pin, or the fifth rising edge, an accumulated value totalling the proper BRG period is left in the SPBRGH:SPBRG registers. Once the 5th edge is seen (should correspond to the STOP bit), the ABDEN bit is automatically cleared.

While calibrating the baud rate period, the BRG registers are clocked at 1/8th the pre-configured clock rate. Note that the BRG clock will be configured by the BRG16 and BRGH bits. Independent of the BRG16 bit setting, both the SPBRG and SPBRGH will be used as a 16-bit counter. This allows the user to verify that no

carry occurred for 8-bit modes, by checking for 00h in the SPBRGH register. Refer to Table 16-4 for counter clock rates to the BRG.

While the ABD sequence takes place, the USART state machine is held in IDLE. The RCIF interrupt is set once the fifth rising edge on RX is detected. The value in the RCREG needs to be read to clear the RCIF interrupt. RCREG content should be discarded.

Note 1: If the WUE bit is set with the ABDEN bit, auto baud rate detection will occur on the byte *following* the Break character (see Section 16.3.4).

2: It is up to the user to determine that the incoming character baud rate is within the range of the selected BRG clock source. Some combinations of oscillator frequency and USART baud rates are not possible due to bit error rates. Overall system timing and communication baud rates must be taken into consideration when using the Auto Baud Rate Detection feature.

TABLE 16-4: BRG COUNTER CLOCK RATES

BRG16	BRGH	BRG Counter Clock
0	0	Fosc/512
0	1	Fosc/128
1	0	Fosc/128
1	1	Fosc/32

Note: During the ABD sequence, SPBRG and SPBRGH are both used as a 16-bit counter, independent of BRG16 setting.

FIGURE 16-1: AUTOMATIC BAUD RATE CALCULATION

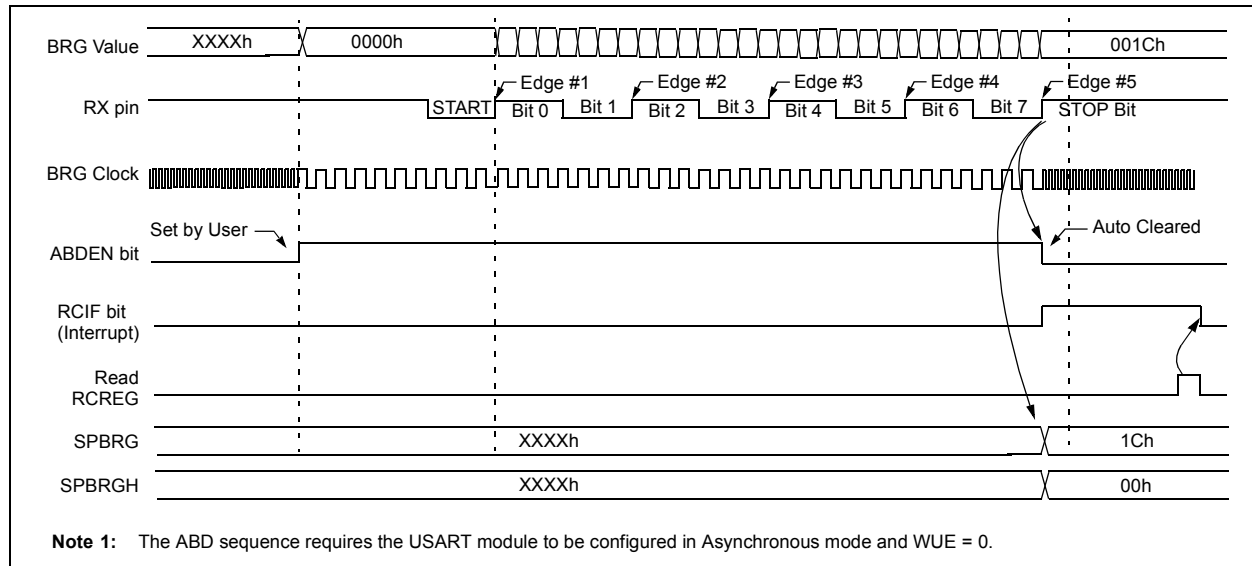

PIC18F1220/1320

16.3 USART Asynchronous Mode

The Asynchronous mode of operation is selected by clearing the SYNC bit (TXSTA<4>). In this mode, the USART uses standard non-return-to-zero (NRZ) format (one START bit, eight or nine data bits and one STOP bit). The most common data format is 8 bits. An on-chip dedicated 8-bit/16-bit baud rate generator can be used to derive standard baud rate frequencies from the oscillator.

The USART transmits and receives the LSb first. The USART's transmitter and receiver are functionally independent, but use the same data format and baud rate. The baud rate generator produces a clock, either x16 or x64 of the bit shift rate, depending on the BRGH and BRG16 bits (TXSTA<2> and BAUDCTL<3>). Parity is not supported by the hardware, but can be implemented in software and stored as the 9th data bit.

Asynchronous mode is available in all Low Power modes; it is available in SLEEP mode only when Auto Wake-up on Sync Break is enabled. When in PRI_IDLE mode, no changes to the baud rate generator values are required; however, other Low Power mode clocks may operate at another frequency than the primary clock. Therefore, the baud rate generator values may need to be adjusted.

When operating in Asynchronous mode, the USART module consists of the following important elements:

- Baud Rate Generator
- Sampling Circuit
- Asynchronous Transmitter
- Asynchronous Receiver
- Auto Wake-up on Sync Break Character
- 12-bit Break Character Transmit
- Auto Baud Rate Detection

16.3.1 USART ASYNCHRONOUS TRANSMITTER

The USART transmitter block diagram is shown in Figure 16-2. The heart of the transmitter is the Transmit (serial) Shift Register (TSR). The shift register obtains its data from the read/write transmit buffer, TXREG. The TXREG register is loaded with data in software. The TSR register is not loaded until the STOP bit has been transmitted from the previous load. As soon as the STOP bit is transmitted, the TSR is loaded with new data from the TXREG register (if available).

Once the TXREG register transfers the data to the TSR register (occurs in one Tcy), the TXREG register is empty and flag bit TXIF (PIR1<4>) is set. This interrupt can be enabled/disabled by setting/clearing enable bit TXIE (PIE1<4>). Flag bit TXIF will be set, regardless of the state of enable bit TXIE and cannot be cleared in software. Flag bit TXIF is not cleared immediately upon loading the transmit buffer register TXREG. TXIF becomes valid in the second instruction cycle following the load instruction. Polling TXIF immediately following a load of TXREG will return invalid results.

While flag bit TXIF indicates the status of the TXREG register, another bit, TRMT (TXSTA<1>), shows the status of the TSR register. Status bit TRMT is a read only bit, which is set when the TSR register is empty. No interrupt logic is tied to this bit, so the user has to poll this bit in order to determine if the TSR register is empty.

Note 1: The TSR register is not mapped in data memory, so it is not available to the user.

2: Flag bit TXIF is set when enable bit TXEN is set.

To set up an Asynchronous Transmission:

1. Initialize the SPBRGH:SPBRG registers for the appropriate baud rate. Set or clear the BRGH and BRG16 bits, as required, to achieve the desired baud rate.
2. Enable the asynchronous serial port by clearing bit SYNC and setting bit SPEN.
3. If interrupts are desired, set enable bit TXIE.
4. If 9-bit transmission is desired, set transmit bit TX9. Can be used as address/data bit.
5. Enable the transmission by setting bit TXEN, which will also set bit TXIF.
6. If 9-bit transmission is selected, the ninth bit should be loaded in bit TX9D.
7. Load data to the TXREG register (starts transmission).

If using interrupts, ensure that the GIE and PEIE bits in the INTCON register (INTCON<7:6>) are set.

FIGURE 16-2: USART TRANSMIT BLOCK DIAGRAM

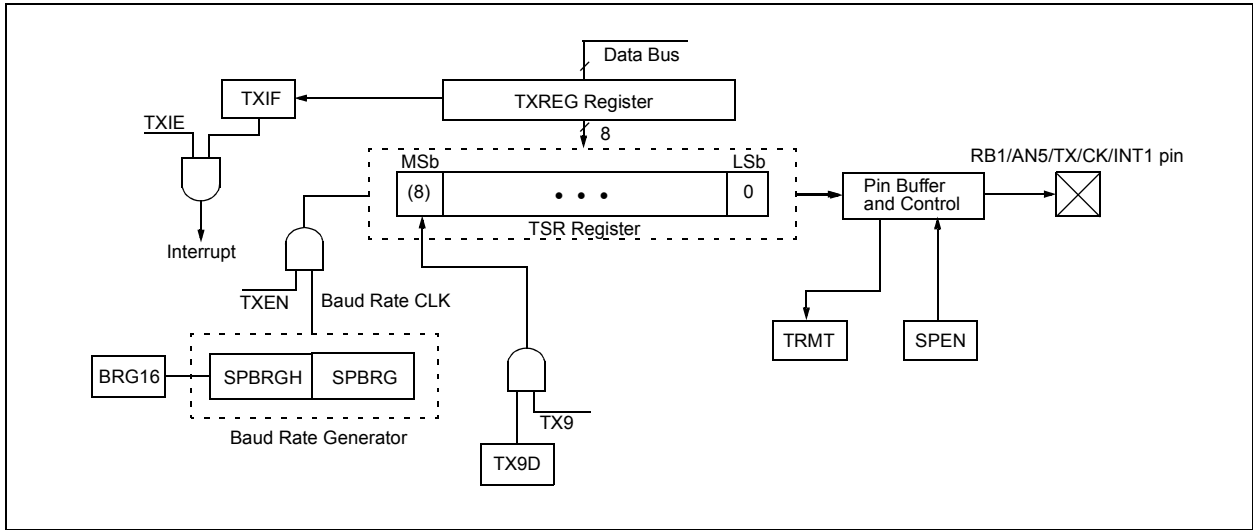

FIGURE 16-3: ASYNCHRONOUS TRANSMISSION

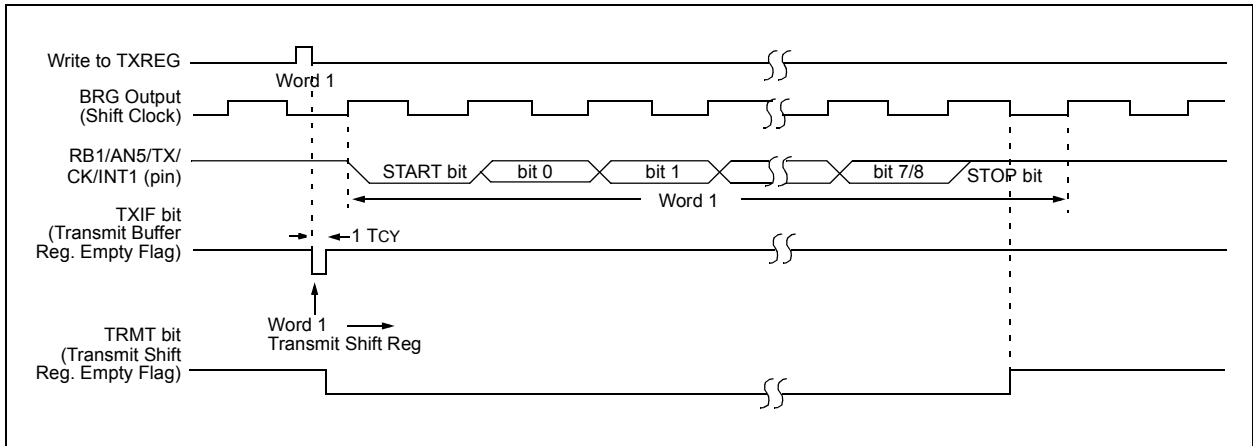
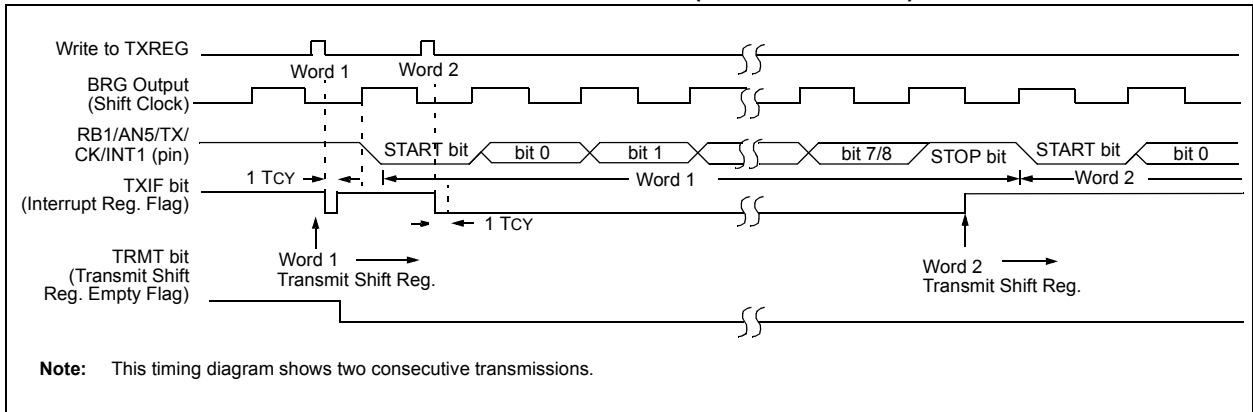

FIGURE 16-4: ASYNCHRONOUS TRANSMISSION (BACK TO BACK)



PIC18F1220/1320

TABLE 16-5: REGISTERS ASSOCIATED WITH ASYNCHRONOUS TRANSMISSION

Name	Bit 7	Bit 6	Bit 5	Bit 4	Bit 3	Bit 2	Bit 1	Bit 0	Value on POR, BOR	Value on all other RESETS
INTCON	GIE/GIEH	PEIE/GIEL	TMR0IE	INT0IE	RBIE	TMR0IF	INT0IF	RBIF	0000 000x	0000 000u
PIR1	—	ADIF	RCIF	TXIF	—	CCP1IF	TMR2IF	TMR1IF	-000 -000	-000 -000
PIE1	—	ADIE	RCIE	TXIE	—	CCP1IE	TMR2IE	TMR1IE	-000 -000	-000 -000
IPR1	—	ADIP	RCIP	TXIP	—	CCP1IP	TMR2IP	TMR1IP	-000 -000	-000 -000
RCSTA	SPEN	RX9	SREN	CREN	ADDEN	FERR	OERR	RX9D	0000 -00x	0000 -00x
TXREG	USART Transmit Register								0000 0000	0000 0000
TXSTA	CSRC	TX9	TXEN	SYNC	SENDB	BRGH	TRMT	TX9D	0000 0010	0000 0010
BAUDCTL	—	RCIDL	—	SCKP	BRG16	—	WUE	ABDEN	-1-1 0-00	-1-1 0-00
SPBRGH	Baud Rate Generator Register, High Byte								0000 0000	0000 0000
SPBRG	Baud Rate Generator Register, Low Byte								0000 0000	0000 0000

Legend: x = unknown, - = unimplemented locations read as '0'. Shaded cells are not used for Asynchronous Transmission.

16.3.2 USART ASYNCHRONOUS RECEIVER

The receiver block diagram is shown in Figure 16-5. The data is received on the RB4/AN6/RX/DT/KBI0 pin and drives the data recovery block. The data recovery block is actually a high speed shifter operating at x16 times the baud rate, whereas the main receive serial shifter operates at the bit rate or at FOSC. This mode would typically be used in RS-232 systems.

To set up an Asynchronous Reception:

1. Initialize the SPBRGH:SPBRG registers for the appropriate baud rate. Set or clear the BRGH and BRG16 bits, as required, to achieve the desired baud rate.
2. Enable the asynchronous serial port by clearing the SYNC bit and setting bit SPEN.
3. If interrupts are desired, set enable bit RCIE.
4. If 9-bit reception is desired, set bit RX9.
5. Enable the reception by setting bit CREN.
6. Flag bit RCIF will be set when reception is complete and an interrupt will be generated if enable bit RCIE was set.
7. Read the RCSTA register to get the 9th bit (if enabled) and determine if any error occurred during reception.
8. Read the 8-bit received data by reading the RCREG register.
9. If any error occurred, clear the error by clearing enable bit CREN.
10. If using interrupts, ensure that the GIE and PEIE bits in the INTCON register (INTCON<7:6>) are set.

16.3.3 SETTING UP 9-BIT MODE WITH ADDRESS DETECT

This mode would typically be used in RS-485 systems. To set up an Asynchronous Reception with Address Detect Enable:

1. Initialize the SPBRGH:SPBRG registers for the appropriate baud rate. Set or clear the BRGH and BRG16 bits, as required, to achieve the desired baud rate.
2. Enable the asynchronous serial port by clearing the SYNC bit and setting the SPEN bit.
3. If interrupts are required, set the RCEN bit and select the desired priority level with the RCIP bit.
4. Set the RX9 bit to enable 9-bit reception.
5. Set the ADDEN bit to enable address detect.
6. Enable reception by setting the CREN bit.
7. The RCIF bit will be set when reception is complete. The interrupt will be Acknowledged if the RCIE and GIE bits are set.
8. Read the RCSTA register to determine if any error occurred during reception, as well as read bit 9 of data (if applicable).
9. Read RCREG to determine if the device is being addressed.
10. If any error occurred, clear the CREN bit.
11. If the device has been addressed, clear the ADDEN bit to allow all received data into the receive buffer and interrupt the CPU.

FIGURE 16-5: USART RECEIVE BLOCK DIAGRAM

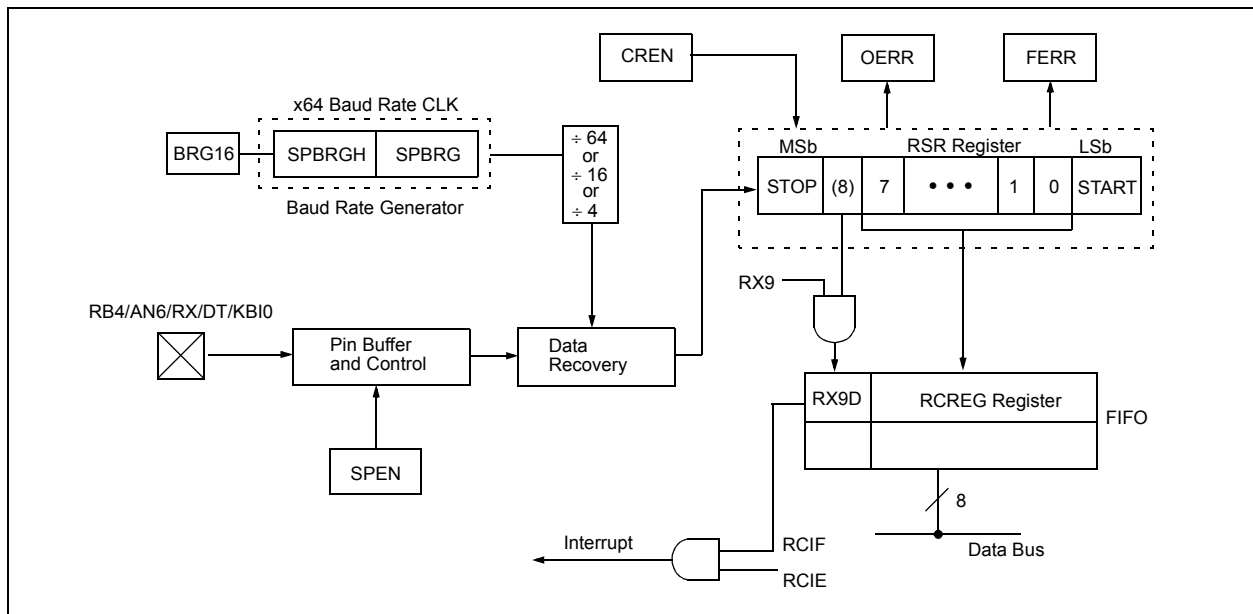

PIC18F1220/1320

To set up an Asynchronous Transmission:

1. Initialize the SPBRG register for the appropriate baud rate. If a high speed baud rate is desired, set bit BRGH (see Section 16.2).
2. Enable the asynchronous serial port by clearing bit SYNC and setting bit SPEN.
3. If interrupts are desired, set enable bit TXIE.
4. If 9-bit transmission is desired, set transmit bit TX9. Can be used as address/data bit.

5. Enable the transmission by setting bit TXEN, which will also set bit TXIF.
6. If 9-bit transmission is selected, the ninth bit should be loaded in bit TX9D.
7. Load data to the TXREG register (starts transmission).

If using interrupts, ensure that the GIE and PEIE bits in the INTCON register (INTCON<7:6>) are set.

FIGURE 16-6: ASYNCHRONOUS RECEPTION

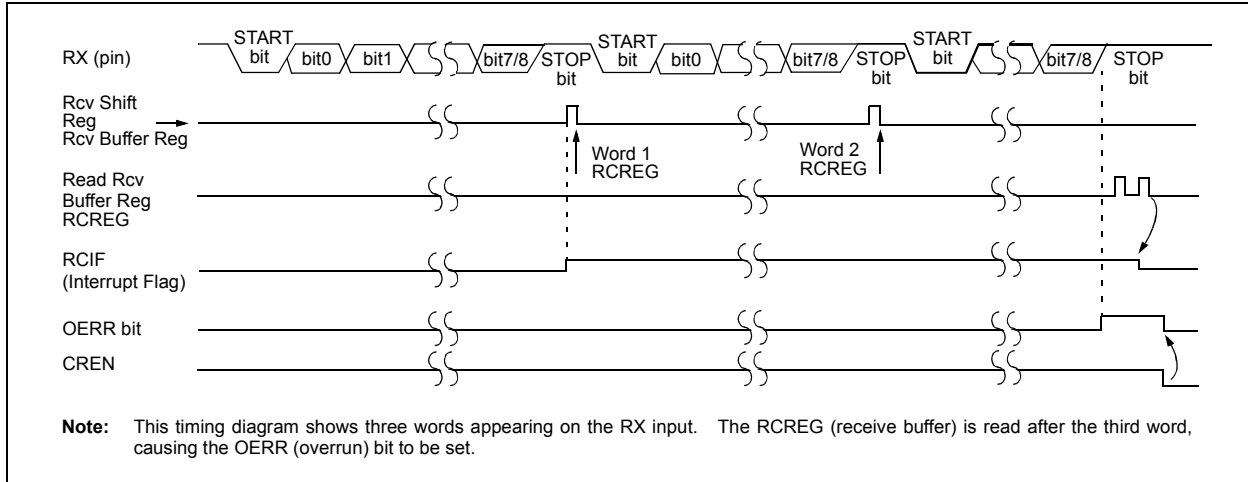

TABLE 16-6: REGISTERS ASSOCIATED WITH ASYNCHRONOUS RECEPTION

Name	Bit 7	Bit 6	Bit 5	Bit 4	Bit 3	Bit 2	Bit 1	Bit 0	Value on POR, BOR	Value on all other RESETS
INTCON	GIE/GIEH	PEIE/GIEL	TMR0IE	INT0IE	RBIE	TMR0IF	INT0IF	RBFIF	0000 000x	0000 000u
PIR1	—	ADIF	RCIF	TXIF	—	CCP1IF	TMR2IF	TMR1IF	-000 -000	-000 -000
PIE1	—	ADIE	RCIE	TXIE	—	CCP1IE	TMR2IE	TMR1IE	-000 -000	-000 -000
IPR1	—	ADIP	RCIP	TXIP	—	CCP1IP	TMR2IP	TMR1IP	-000 -000	-000 -000
RCSTA	SPEN	RX9	SREN	CREN	ADDEN	FERR	OERR	RX9D	0000 -00x	0000 -00x
RCREG	USART Receive Register								0000 0000	0000 0000
TXSTA	CSRC	TX9	TXEN	SYNC	SENDB	BRGH	TRMT	TX9D	0000 0010	0000 0010
BAUDCTL	—	RCIDL	—	SCKP	BRG16	—	WUE	ABDEN	-1-1 0-00	-1-1 0-00
SPBRGH	Baud Rate Generator Register, High Byte								0000 0000	0000 0000
SPBRG	Baud Rate Generator Register, Low Byte								0000 0000	0000 0000

Legend: x = unknown, - = unimplemented locations read as '0'. Shaded cells are not used for Asynchronous Reception.

16.3.4 AUTO WAKE-UP ON SYNC BREAK CHARACTER

During SLEEP mode, all clocks to the USART are suspended. Because of this, the baud rate generator is inactive and a proper byte reception cannot be performed. The Auto Wake-up feature allows the controller to wake-up due to activity on the RX/DT line, while the USART is operating in Asynchronous mode.

The Auto Wake-up feature is enabled by setting the WUE bit (BAUDCTL<1>). Once set, the typical receive sequence on RX/DT is disabled, and the USART remains in an IDLE state, monitoring for a wake-up event independent of the CPU mode. A wake-up event consists of a high-to-low transition on the RX/DT line. (This coincides with the start of a Sync Break or a Wake-up Signal character for the LIN protocol.)

Following a wake-up event, the module generates an RCIF interrupt. The interrupt is generated synchronously to the Q clocks in normal Operating modes (Figure 16-7), and asynchronously if the device is in SLEEP mode (Figure 16-8). The interrupt condition is cleared by reading the RCREG register.

The WUE bit is automatically cleared once a low-to-high transition is observed on the RX line, following the wake-up event. At this point, the USART module is in IDLE mode and returns to normal operation. This signals to the user that the Sync Break event is over.

16.3.4.1 Special Considerations Using Auto Wake-up

Since Auto Wake-up functions by sensing rising edge transitions on RX/DT, information with any state changes before the STOP bit may signal a false end-of-character

and cause data or framing errors. To work properly, therefore, the initial character in the transmission must be all '0's. This can be 00h (8 bytes) for standard RS-232 devices, or 000h (12 bits) for LIN bus.

Oscillator start-up time must also be considered, especially in applications using oscillators with longer start-up intervals (i.e., XT or HS mode). The Sync Break (or Wake-up Signal) character must be of sufficient length, and be followed by a sufficient interval, to allow enough time for the selected oscillator to start and provide proper initialization of the USART.

16.3.4.2 Special Considerations Using the WUE Bit

The timing of WUE and RCIF events may cause some confusion when it comes to determining the validity of received data. As noted, setting the WUE bit places the USART in an IDLE mode. The wake-up event causes a receive interrupt by setting the RCIF bit. The WUE bit is cleared after this when a rising edge is seen on RX/DT. The interrupt condition is then cleared by reading the RCREG register. Ordinarily, the data in RCREG will be dummy data and should be discarded.

The fact that the WUE bit has been cleared (or is still set) and the RCIF flag is set should not be used as an indicator of the integrity of the data in RCREG. Users should consider implementing a parallel method in firmware to verify received data integrity.

To assure that no actual data is lost, check the RCIDL bit to verify that a receive operation is not in process. If a receive operation is not occurring, the WUE bit may then be set just prior to entering the SLEEP mode.

FIGURE 16-7: AUTO WAKE-UP BIT (WUE) TIMINGS DURING NORMAL OPERATION

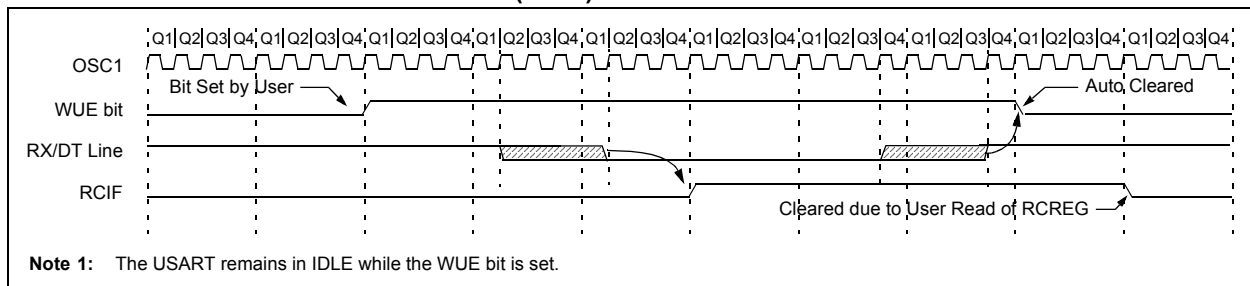
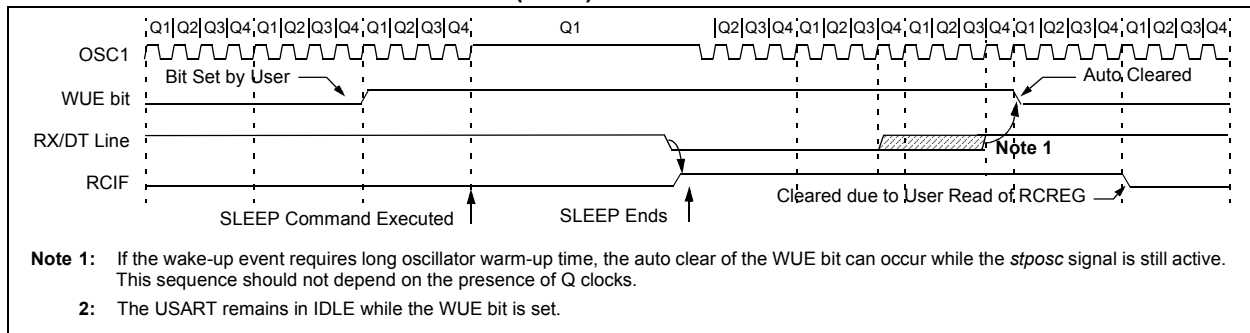

FIGURE 16-8: AUTO WAKE-UP BIT (WUE) TIMINGS DURING SLEEP



PIC18F1220/1320

16.3.5 BREAK CHARACTER SEQUENCE

The Enhanced USART module has the capability of sending the special Break character sequences that are required by the LIN bus standard. The Break character transmit consists of a START bit, followed by 12 '0' bits and a STOP bit. The frame Break character is sent whenever the SENDB and TXEN bits (TXSTA<3> and TXSTA<5>) are set, while the transmit shift register is loaded with data. Note that the value of data written to TXREG will be ignored and all '0's will be transmitted.

The SENDB bit is automatically reset by hardware after the corresponding STOP bit is sent. This allows the user to preload the transmit FIFO with the next transmit byte following the Break character (typically, the Sync character in the LIN specification).

Note that the data value written to the TXREG for the Break character is ignored. The write simply serves the purpose of initiating the proper sequence.

The TRMT bit indicates when the transmit operation is active or IDLE, just as it does during normal transmission. See Figure 16-9 for the timing of the Break character sequence.

16.3.5.1 Break and Sync Transmit Sequence

The following sequence will send a message frame header made up of a Break, followed by an auto baud Sync byte. This sequence is typical of a LIN bus master.

1. Configure the USART for the desired mode.
2. Set the TXEN and SENDB bits to setup the Break character.
3. Load the TXREG with a dummy character to initiate transmission (the value is ignored).
4. Write '55h' to TXREG to load the Sync character into the transmit FIFO buffer.
5. After the Break has been sent, the SENDB bit is reset by hardware. The Sync character now transmits in the Pre-Configured mode.

When the TXREG becomes empty, as indicated by the TXIF, the next data byte can be written to TXREG.

16.3.6 RECEIVING A BREAK CHARACTER

The Enhanced USART module can receive a Break character in two ways.

The first method forces to configure the baud rate at a frequency of 9/13 the typical speed. This allows for the STOP bit transition to be at the correct sampling location (13 bits for Break versus START bit and 8 data bits for typical data).

The second method uses the Auto Wake-up feature described in Section 16.3.4. By enabling this feature, the USART will sample the next two transitions on RX/DT, cause an RCIF interrupt, and receive the next data byte followed by another interrupt.

Note that following a Break character, the user will typically want to enable the Auto Baud Rate detect feature. For both methods, the user can set the ABD bit once the TXIF interrupt is observed.

FIGURE 16-9: SEND BREAK CHARACTER SEQUENCE

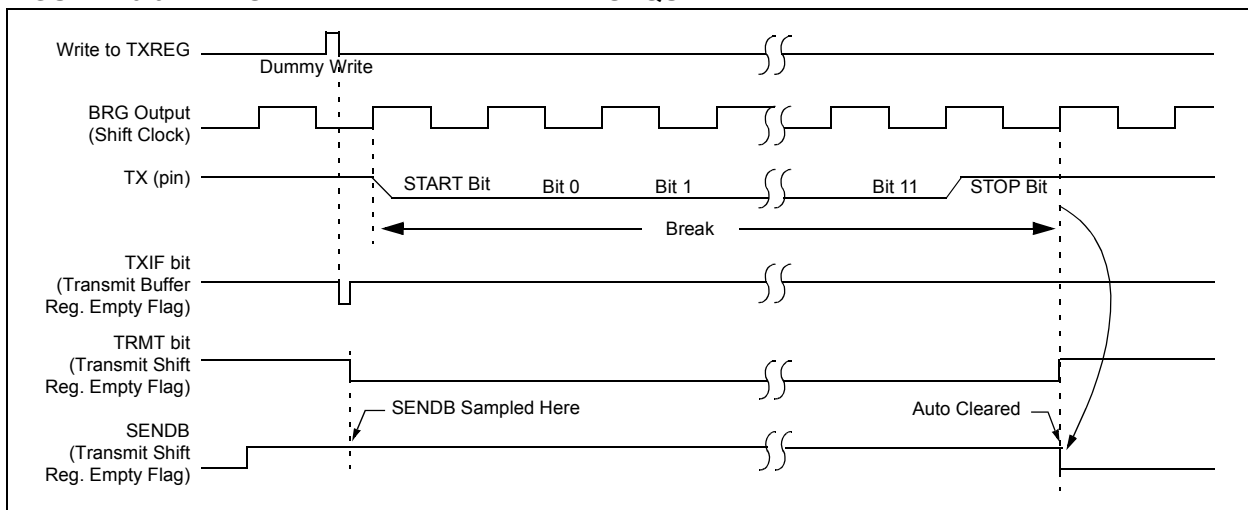

16.4 USART Synchronous Master Mode

The Synchronous Master mode is entered by setting the CSRC bit (TXSTA<7>). In this mode, the data is transmitted in a half-duplex manner (i.e., transmission and reception do not occur at the same time). When transmitting data, the reception is inhibited and vice versa. Synchronous mode is entered by setting bit SYNC (TXSTA<4>). In addition, enable bit SPEN (RCSTA<7>) is set in order to configure the RB1/AN5/TX/CK/INT1 and RB4/AN6/RX/DT/KBI0 I/O pins to CK (clock) and DT (data) lines, respectively.

The Master mode indicates that the processor transmits the master clock on the CK line. Clock polarity is selected with the SCKP bit (BAUDCTL<5>); setting SCKP sets the IDLE state on CK as high, while clearing the bit sets the IDLE state is low. This option is provided to support Microwire® devices with this module.

16.4.1 USART SYNCHRONOUS MASTER TRANSMISSION

The USART transmitter block diagram is shown in Figure 16-2. The heart of the transmitter is the Transmit (serial) Shift Register (TSR). The shift register obtains its data from the read/write transmit buffer register TXREG. The TXREG register is loaded with data in software. The TSR register is not loaded until the last bit has been transmitted from the previous load. As soon as the last bit is transmitted, the TSR is loaded with new data from the TXREG (if available).

Once the TXREG register transfers the data to the TSR register (occurs in one T_{CYCLE}), the TXREG is empty and interrupt bit TXIF (PIR1<4>) is set. The interrupt can be enabled/disabled by setting/clearing enable bit TXIE (PIE1<4>). Flag bit TXIF will be set, regardless of the state of enable bit TXIE, and cannot be cleared in software. It will reset only when new data is loaded into the TXREG register.

While flag bit TXIF indicates the status of the TXREG register, another bit, TRMT (TXSTA<1>), shows the status of the TSR register. TRMT is a read only bit, which is set when the TSR is empty. No interrupt logic is tied to this bit, so the user has to poll this bit in order to determine if the TSR register is empty. The TSR is not mapped in data memory, so it is not available to the user.

To set up a Synchronous Master Transmission:

1. Initialize the SPBRGH:SPBRG registers for the appropriate baud rate. Set or clear the BRGH and BRG16 bits, as required, to achieve the desired baud rate.
2. Enable the synchronous master serial port by setting bits SYNC, SPEN, and CSRC.
3. If interrupts are desired, set enable bit TXIE.
4. If 9-bit transmission is desired, set bit TX9.
5. Enable the transmission by setting bit TXEN.
6. If 9-bit transmission is selected, the ninth bit should be loaded in bit TX9D.
7. Start transmission by loading data to the TXREG register.
8. If using interrupts, ensure that the GIE and PEIE bits in the INTCON register (INTCON<7:6>) are set.

FIGURE 16-10: SYNCHRONOUS TRANSMISSION

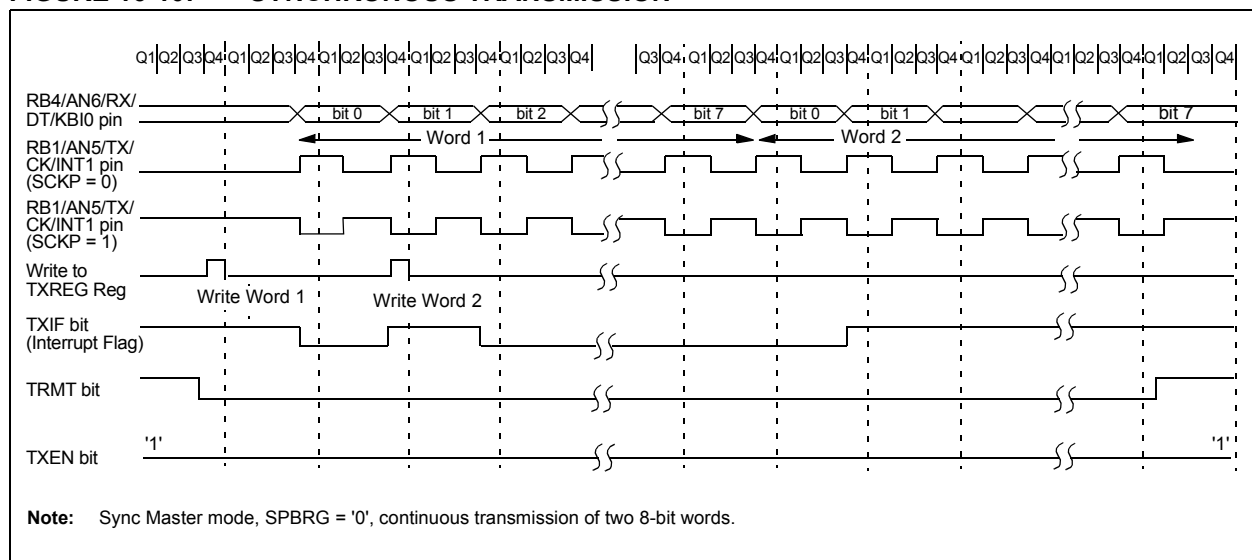

PIC18F1220/1320

FIGURE 16-11: SYNCHRONOUS TRANSMISSION (THROUGH TXEN)

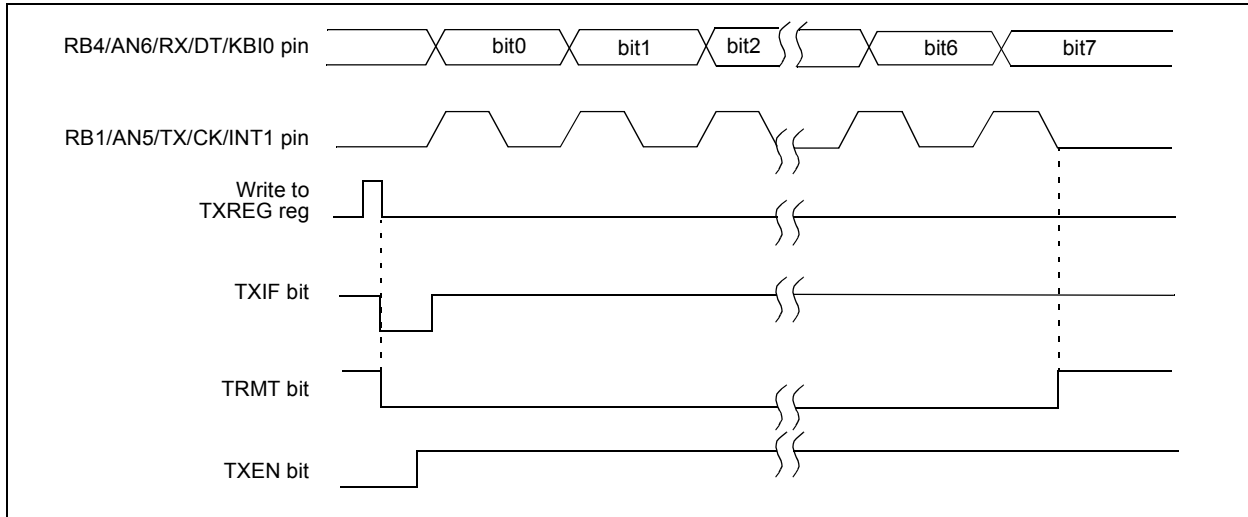

TABLE 16-7: REGISTERS ASSOCIATED WITH SYNCHRONOUS MASTER TRANSMISSION

Name	Bit 7	Bit 6	Bit 5	Bit 4	Bit 3	Bit 2	Bit 1	Bit 0	Value on POR, BOR	Value on all other RESETS
INTCON	GIE/GIEH	PEIE/GIEL	TMR0IE	INT0IE	RBIE	TMR0IF	INT0IF	RBIF	0000 000x	0000 000u
PIR1	—	ADIF	RCIF	TXIF	—	CCP1IF	TMR2IF	TMR1IF	-000 -000	-000 -000
PIE1	—	ADIE	RCIE	TXIE	—	CCP1IE	TMR2IE	TMR1IE	-000 -000	-000 -000
IPR1	—	ADIP	RCIP	TXIP	—	CCP1IP	TMR2IP	TMR1IP	-000 -000	-000 -000
RCSTA	SPEN	RX9	SREN	CREN	ADDEN	FERR	OERR	RX9D	0000 -00x	0000 -00x
TXREG	USART Transmit Register								0000 0000	0000 0000
TXSTA	CSRC	TX9	TXEN	SYNC	SENDB	BRGH	TRMT	TX9D	0000 0010	0000 0010
BAUDCTL	—	RCIDL	—	SCKP	BRG16	—	WUE	ABDEN	-1-1 0-00	-1-1 0-00
SPBRGH	Baud Rate Generator Register, High Byte								0000 0000	0000 0000
SPBRG	Baud Rate Generator Register, Low Byte								0000 0000	0000 0000

Legend: x = unknown, - = unimplemented, read as '0'. Shaded cells are not used for Synchronous Master Transmission.

16.4.2 USART SYNCHRONOUS MASTER RECEPTION

Once Synchronous mode is selected, reception is enabled by setting either the Single Receive Enable bit SREN (RCSTA<5>), or the Continuous Receive Enable bit CREN (RCSTA<4>). Data is sampled on the RB4/AN6/RX/DT/KBI0 pin on the falling edge of the clock.

If enable bit SREN is set, only a single word is received. If enable bit CREN is set, the reception is continuous until CREN is cleared. If both bits are set, then CREN takes precedence.

To set up a Synchronous Master Reception:

1. Initialize the SPBRGH:SPBRG registers for the appropriate baud rate. Set or clear the BRGH and BRG16 bits, as required, to achieve the desired baud rate.
2. Enable the synchronous master serial port by setting bits SYNC, SPEN and CSRC.
3. Ensure bits CREN and SREN are clear.
4. If interrupts are desired, set enable bit RCIE.
5. If 9-bit reception is desired, set bit RX9.
6. If a single reception is required, set bit SREN. For continuous reception, set bit CREN.
7. Interrupt flag bit RCIF will be set when reception is complete and an interrupt will be generated if the enable bit RCIE was set.
8. Read the RCSTA register to get the 9th bit (if enabled) and determine if any error occurred during reception.
9. Read the 8-bit received data by reading the RCREG register.
10. If any error occurred, clear the error by clearing bit CREN.
11. If using interrupts, ensure that the GIE and PEIE bits in the INTCON register (INTCON<7:6>) are set.

FIGURE 16-12: SYNCHRONOUS RECEPTION (MASTER MODE, SREN)

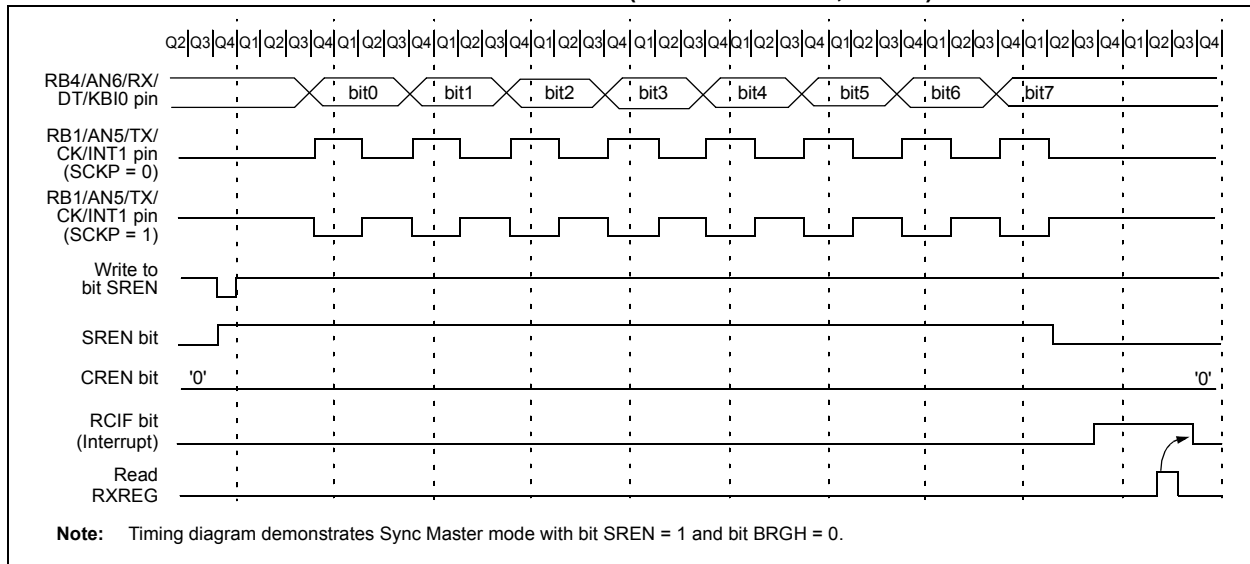

PIC18F1220/1320

TABLE 16-8: REGISTERS ASSOCIATED WITH SYNCHRONOUS MASTER RECEPTION

Name	Bit 7	Bit 6	Bit 5	Bit 4	Bit 3	Bit 2	Bit 1	Bit 0	Value on POR, BOR	Value on all other RESETS
INTCON	GIE/GIEH	PEIE/GIEL	TMR0IE	INT0IE	RBIE	TMR0IF	INT0IF	RBIF	0000 000x	0000 000u
PIR1	—	ADIF	RCIF	TXIF	—	CCP1IF	TMR2IF	TMR1IF	-000 -000	-000 -000
PIE1	—	ADIE	RCIE	TXIE	—	CCP1IE	TMR2IE	TMR1IE	-000 -000	-000 -000
IPR1	—	ADIP	RCIP	TXIP	—	CCP1IP	TMR2IP	TMR1IP	-000 -000	-000 -000
RCSTA	SPEN	RX9	SREN	CREN	ADDEN	FERR	OERR	RX9D	0000 -00x	0000 -00x
RCREG	USART Receive Register								0000 0000	0000 0000
TXSTA	CSRC	TX9	TXEN	SYNC	SEnDB	BRGH	TRMT	TX9D	0000 0010	0000 0010
BAUDCTL	—	RCIDL	—	SCKP	BRG16	—	WUE	ABDEN	-1-1 0-00	-1-1 0-00
SPBRGH	Baud Rate Generator Register, High Byte								0000 0000	0000 0000
SPBRG	Baud Rate Generator Register, Low Byte								0000 0000	0000 0000

Legend: x = unknown, - = unimplemented, read as '0'. Shaded cells are not used for Synchronous Master Reception.

16.5 USART Synchronous Slave Mode

Synchronous Slave mode is entered by clearing bit CSRC (TXSTA<7>). This mode differs from the Synchronous Master mode in that the shift clock is supplied externally at the RB1/AN5/TX/CK/INT1 pin (instead of being supplied internally in Master mode). This allows the device to transfer or receive data while in any Low Power mode.

16.5.1 USART SYNCHRONOUS SLAVE TRANSMIT

The operation of the Synchronous Master and Slave modes are identical, except in the case of the SLEEP mode.

If two words are written to the TXREG and then the SLEEP instruction is executed, the following will occur:

- a) The first word will immediately transfer to the TSR register and transmit.
- b) The second word will remain in TXREG register.
- c) Flag bit TXIF will not be set.
- d) When the first word has been shifted out of TSR, the TXREG register will transfer the second word to the TSR and flag bit TXIF will now be set.
- e) If enable bit TXIE is set, the interrupt will wake the chip from SLEEP. If the global interrupt is enabled, the program will branch to the interrupt vector.

To set up a Synchronous Slave Transmission:

1. Enable the synchronous slave serial port by setting bits SYNC and SPEN and clearing bit CSRC.
2. Clear bits CREN and SREN.
3. If interrupts are desired, set enable bit TXIE.
4. If 9-bit transmission is desired, set bit TX9.
5. Enable the transmission by setting enable bit TXEN.
6. If 9-bit transmission is selected, the ninth bit should be loaded in bit TX9D.
7. Start transmission by loading data to the TXREG register.
8. If using interrupts, ensure that the GIE and PEIE bits in the INTCON register (INTCON<7:6>) are set.

TABLE 16-9: REGISTERS ASSOCIATED WITH SYNCHRONOUS SLAVE TRANSMISSION

Name	Bit 7	Bit 6	Bit 5	Bit 4	Bit 3	Bit 2	Bit 1	Bit 0	Value on POR, BOR	Value on all other RESETS
INTCON	GIE/GIEH	PEIE/GIEL	TMR0IE	INT0IE	RBIE	TMR0IF	INT0IF	RBIF	0000 000x	0000 000u
PIR1	—	ADIF	RCIF	TXIF	—	CCP1IF	TMR2IF	TMR1IF	-000 -000	-000 -000
PIE1	—	ADIE	RCIE	TXIE	—	CCP1IE	TMR2IE	TMR1IE	-000 -000	-000 -000
IPR1	—	ADIP	RCIP	TXIP	—	CCP1IP	TMR2IP	TMR1IP	-000 -000	-000 -000
RCSTA	SPEN	RX9	SREN	CREN	ADDEN	FERR	OERR	RX9D	0000 -00x	0000 -00x
TXREG	USART Transmit Register								0000 0000	0000 0000
TXSTA	CSRC	TX9	TXEN	SYNC	SENDB	BRGH	TRMT	TX9D	0000 0010	0000 0010
BAUDCTL	—	RCIDL	—	SCKP	BRG16	—	WUE	ABDEN	-1-1 0-00	-1-1 0-00
SPBRGH	Baud Rate Generator Register, High Byte								0000 0000	0000 0000
SPBRG	Baud Rate Generator Register, Low Byte								0000 0000	0000 0000

Legend: x = unknown, - = unimplemented, read as '0'. Shaded cells are not used for Synchronous Slave Transmission.

PIC18F1220/1320

16.5.2 USART SYNCHRONOUS SLAVE RECEPTION

The operation of the Synchronous Master and Slave modes is identical, except in the case of SLEEP, or any IDLE mode and bit SREN, which is a “don't care” in Slave mode.

If receive is enabled by setting the CREN bit prior to entering SLEEP or any IDLE mode, then a word may be received while in this Low Power mode. Once the word is received, the RSR register will transfer the data to the RCREG register; if the RCIE enable bit is set, the interrupt generated will wake the chip from Low Power mode. If the global interrupt is enabled, the program will branch to the interrupt vector.

To set up a Synchronous Slave Reception:

1. Enable the synchronous master serial port by setting bits SYNC and SPEN and clearing bit CSRC.
2. If interrupts are desired, set enable bit RCIE.
3. If 9-bit reception is desired, set bit RX9.
4. To enable reception, set enable bit CREN.
5. Flag bit RCIF will be set when reception is complete. An interrupt will be generated if enable bit RCIE was set.
6. Read the RCSTA register to get the 9th bit (if enabled) and determine if any error occurred during reception.
7. Read the 8-bit received data by reading the RCREG register.
8. If any error occurred, clear the error by clearing bit CREN.
9. If using interrupts, ensure that the GIE and PEIE bits in the INTCON register (INTCON<7:6>) are set.

TABLE 16-10: REGISTERS ASSOCIATED WITH SYNCHRONOUS SLAVE RECEPTION

Name	Bit 7	Bit 6	Bit 5	Bit 4	Bit 3	Bit 2	Bit 1	Bit 0	Value on POR, BOR	Value on all other RESETS
INTCON	GIE/GIEH	PEIE/GIEL	TMR0IE	INT0IE	RBIE	TMR0IF	INT0IF	RBIF	0000 000x	0000 000u
PIR1	—	ADIF	RCIF	TXIF	—	CCP1IF	TMR2IF	TMR1IF	0000 0000	0000 0000
PIE1	—	ADIE	RCIE	TXIE	—	CCP1IE	TMR2IE	TMR1IE	0000 0000	0000 0000
IPR1	—	ADIP	RCIP	TXIP	—	CCP1IP	TMR2IP	TMR1IP	0000 0000	0000 0000
RCSTA	SPEN	RX9	SREN	CREN	ADDEN	FERR	OERR	RX9D	0000 -00x	0000 -00x
RCREG	USART Receive Register								0000 0000	0000 0000
TXSTA	CSRC	TX9	TXEN	SYNC	SEnDB	BRGH	TRMT	TX9D	0000 0010	0000 0010
BAUDCTL	—	RCIDL	—	SCKP	BRG16	—	WUE	ABDEN	-1-1 0-00	-1-1 0-00
SPBRGH	Baud Rate Generator Register, High Byte								0000 0000	0000 0000
SPBRG	Baud Rate Generator Register, Low Byte								0000 0000	0000 0000

Legend: x = unknown, - = unimplemented, read as '0'. Shaded cells are not used for Synchronous Slave Reception.

17.0 10-BIT ANALOG-TO-DIGITAL CONVERTER (A/D) MODULE

The Analog-to-Digital (A/D) converter module has 7 inputs for the PIC18F1220/1320 devices. This module allows conversion of an analog input signal to a corresponding 10-bit digital number.

A new feature for the A/D converter is the addition of programmable acquisition time. This feature allows the user to select a new channel for conversion and setting the GO/DONE bit immediately. When the GO/DONE bit is set, the selected channel is sampled for the programmed acquisition time before a conversion is actually started. This removes the firmware overhead that may have been required to allow for an acquisition (sampling) period (see Register 17-3 and Section 17.3).

The module has five registers:

- A/D Result High Register (ADRESH)
- A/D Result Low Register (ADRESL)
- A/D Control Register 0 (ADCON0)
- A/D Control Register 1 (ADCON1)
- A/D Control Register 2 (ADCON2)

The ADCON0 register, shown in Register 17-1, controls the operation of the A/D module. The ADCON1 register, shown in Register 17-2, configures the functions of the port pins. The ADCON2 register, shown in Register 17-3, configures the A/D clock source, programmed acquisition time and justification.

REGISTER 17-1: ADCON0 REGISTER

R/W-0	R/W-0	U-0	R/W-0	R/W-0	R/W-0	R/W-0	R/W-0	
VCFG1	VCFG0	—	CHS2	CHS1	CHS0	GO/DONE	ADON	
bit 7								bit 0

bit 7-6 **VCFG<1:0>**: Voltage Reference Configuration bits

	A/D VREF+	A/D VREF-
00	AVDD	AVSS
01	External VREF+	AVSS
10	AVDD	External VREF-
11	External VREF+	External VREF-

bit 5 **Unimplemented**: Read as '0'

bit 4-3 **CHS2:CHS0**: Analog Channel Select bits

000 = Channel 0 (AN0)
 001 = Channel 1 (AN1)
 010 = Channel 2 (AN2)
 011 = Channel 3 (AN3)
 100 = Channel 4 (AN4)
 101 = Channel 5 (AN5)
 110 = Channel 6 (AN6)
 111 = Unimplemented⁽¹⁾

bit 1 **GO/DONE**: A/D Conversion Status bit

When ADON = 1:

1 = A/D conversion in progress
 0 = A/D IDLE

bit 0 **ADON**: A/D On bit

1 = A/D converter module is enabled
 0 = A/D converter module is disabled

Note 1: Performing a conversion on unimplemented channels returns full scale results.

Legend:			
R = Readable bit	W = Writable bit	U = Unimplemented bit, read as '0'	
- n = Value at POR	'1' = Bit is set	'0' = Bit is cleared	x = Bit is unknown

PIC18F1220/1320

REGISTER 17-2: ADCON1 – A/D CONTROL REGISTER 1

U-0	R/W-0	R/W-0	R/W-0	R/W-0	R/W-0	R/W-0	R/W-0
—	PCFG6	PCFG5	PCFG4	PCFG3	PCFG2	PCFG1	PCFG0
bit 7							bit 0

- bit 7 **Unimplemented:** Read as '0'
- bit 6 **PCFG6:** A/D Port Configuration bit - AN6
1 = Pin configured as a digital port
0 = Pin configured as an analog channel - digital input disabled and reads '0'
- bit 5 **PCFG5:** A/D Port Configuration bit - AN5
1 = Pin configured as a digital port
0 = Pin configured as an analog channel - digital input disabled and reads '0'
- bit 4 **PCFG4:** A/D Port Configuration bit - AN4
1 = Pin configured as a digital port
0 = Pin configured as an analog channel - digital input disabled and reads '0'
- bit 3 **PCFG3:** A/D Port Configuration bit - AN3
1 = Pin configured as a digital port
0 = Pin configured as an analog channel - digital input disabled and reads '0'
- bit 2 **PCFG2:** A/D Port Configuration bit - AN2
1 = Pin configured as a digital port
0 = Pin configured as an analog channel - digital input disabled and reads '0'
- bit 1 **PCFG1:** A/D Port Configuration bit - AN1
1 = Pin configured as a digital port
0 = Pin configured as an analog channel - digital input disabled and reads '0'
- bit 0 **PCFG0:** A/D Port Configuration bit - AN0
1 = Pin configured as a digital port
0 = Pin configured as an analog channel - digital input disabled and reads '0'

Legend:

R = Readable bit	W = Writable bit	U = Unimplemented bit, read as '0'
-n = Value at POR	'1' = Bit is set	'0' = Bit is cleared x = Bit is unknown

REGISTER 17-3: ADCON2 REGISTER

R/W-0	U-0	R/W-0	R/W-0	R/W-0	R/W-0	R/W-0	R/W-0
ADFM	—	ACQT2	ACQT1	ACQT0	ADCS2	ADCS1	ADCS0
bit 7							bit 0

- bit 7 **ADFM:** A/D Result Format Select bit
 1 = Right justified
 0 = Left justified
- bit 6 **Unimplemented:** Read as '0'
- bit 5-3 **ACQT2:ACQT0:** A/D Acquisition Time Select bits
 000 = 0 TAD⁽¹⁾
 001 = 2 TAD
 010 = 4 TAD
 011 = 6 TAD
 100 = 8 TAD
 101 = 12 TAD
 110 = 16 TAD
 111 = 20 TAD
- bit 2-0 **ADCS2:ADCS0:** A/D Conversion Clock Select bits
 000 = Fosc/2
 001 = Fosc/8
 010 = Fosc/32
 011 = FRC (clock derived from A/D RC oscillator)⁽¹⁾
 100 = Fosc/4
 101 = Fosc/16
 110 = Fosc/64
 111 = FRC (clock derived from A/D RC oscillator)⁽¹⁾

Note 1: If the A/D FRC clock source is selected, a delay of one T_{cy} (instruction cycle) is added before the A/D clock starts. This allows the SLEEP instruction to be executed before starting a conversion.

Legend:

R = Readable bit	W = Writable bit	U = Unimplemented bit, read as '0'
- n = Value at POR	'1' = Bit is set	'0' = Bit is cleared x = Bit is unknown

PIC18F1220/1320

The analog reference voltage is software selectable to either the device's positive and negative supply voltage (AVDD and AVSS), or the voltage level on the RA3/AN3/VREF+ and RA2/AN2/VREF- pins.

The A/D converter has a unique feature of being able to operate while the device is in SLEEP mode. To operate in SLEEP, the A/D conversion clock must be derived from the A/D's internal RC oscillator.

The output of the sample and hold is the input into the converter, which generates the result via successive approximation.

A device RESET forces all registers to their RESET state. This forces the A/D module to be turned off and any conversion in progress is aborted.

Each port pin associated with the A/D converter can be configured as an analog input, or as a digital I/O. The ADRESH and ADRESL registers contain the result of the A/D conversion. When the A/D conversion is complete, the result is loaded into the ADRESH/ADRESL registers, the GO/DONE bit (ADCON0 register) is cleared, and A/D interrupt flag bit ADIF is set. The block diagram of the A/D module is shown in Figure 17-1.

FIGURE 17-1: A/D BLOCK DIAGRAM

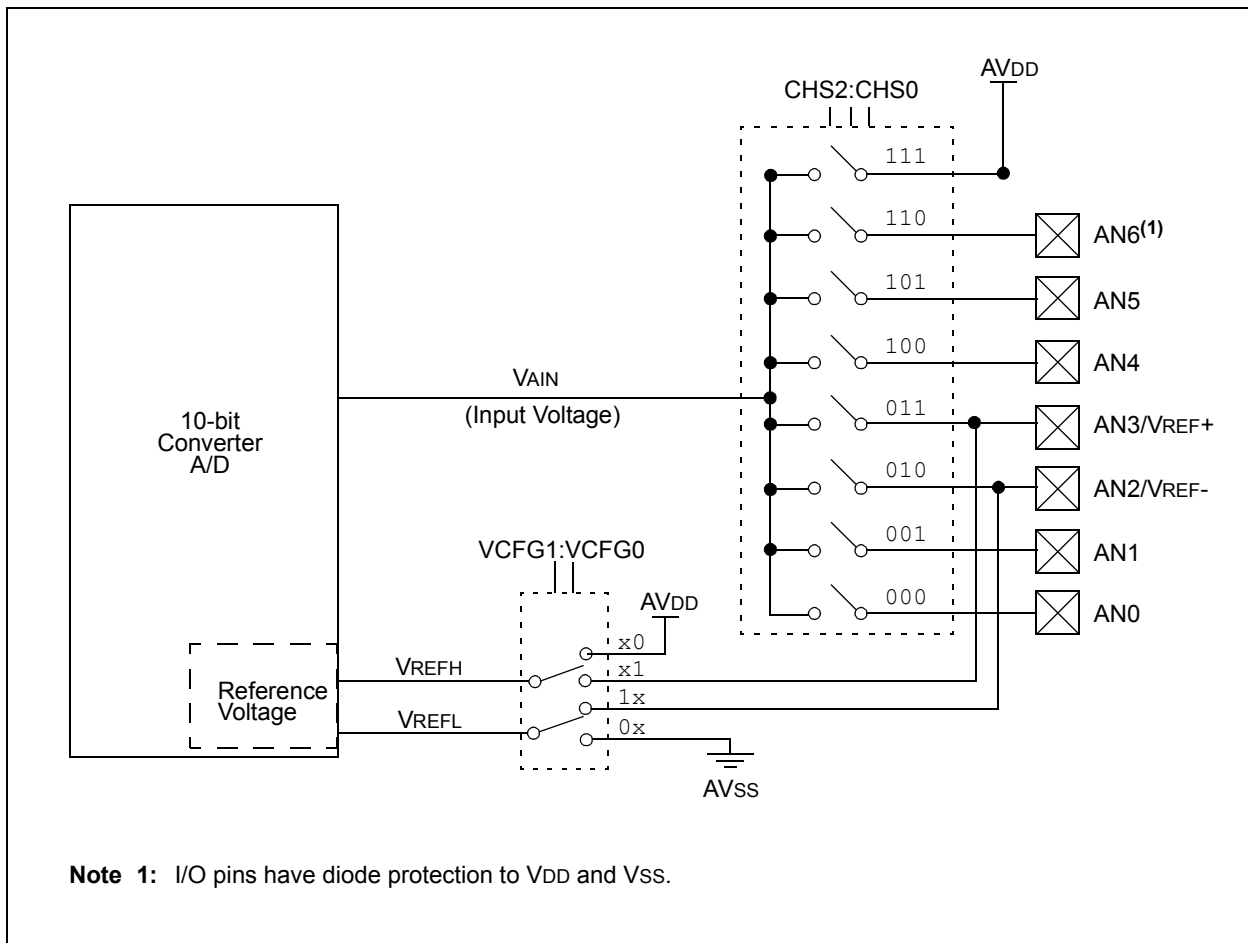

The value in the ADRESH/ADRESL registers is not modified for a Power-on Reset. The ADRESH/ADRESL registers will contain unknown data after a Power-on Reset.

After the A/D module has been configured as desired, the selected channel must be acquired before the conversion is started. The analog input channels must have their corresponding TRIS bits selected as an input. To determine acquisition time, see Section 17.1. After this acquisition time has elapsed, the A/D conversion can be started. An acquisition time can be programmed to occur between setting the GO/DONE bit and the actual start of the conversion.

The following steps should be followed to do an A/D Conversion:

1. Configure the A/D module:
 - Configure analog pins, voltage reference and digital I/O (ADCON1)
 - Select A/D input channel (ADCON0)
 - Select A/D acquisition time (ADCON2)
 - Select A/D conversion clock (ADCON2)
 - Turn on A/D module (ADCON0)
2. Configure A/D interrupt (if desired):
 - Clear ADIF bit
 - Set ADIE bit
 - Set GIE bit
3. Wait the required acquisition time (if required).
4. Start conversion:
 - Set GO/DONE bit (ADCON0 register)
5. Wait for A/D conversion to complete, by either:
 - Polling for the GO/DONE bit to be cleared
 - OR
 - Waiting for the A/D interrupt
6. Read A/D Result registers (ADRESH:ADRESL); clear bit ADIF, if required.
7. For next conversion, go to step 1 or step 2, as required. The A/D conversion time per bit is defined as TAD. A minimum wait of 2 TAD is required before next acquisition starts.

FIGURE 17-2: ANALOG INPUT MODEL

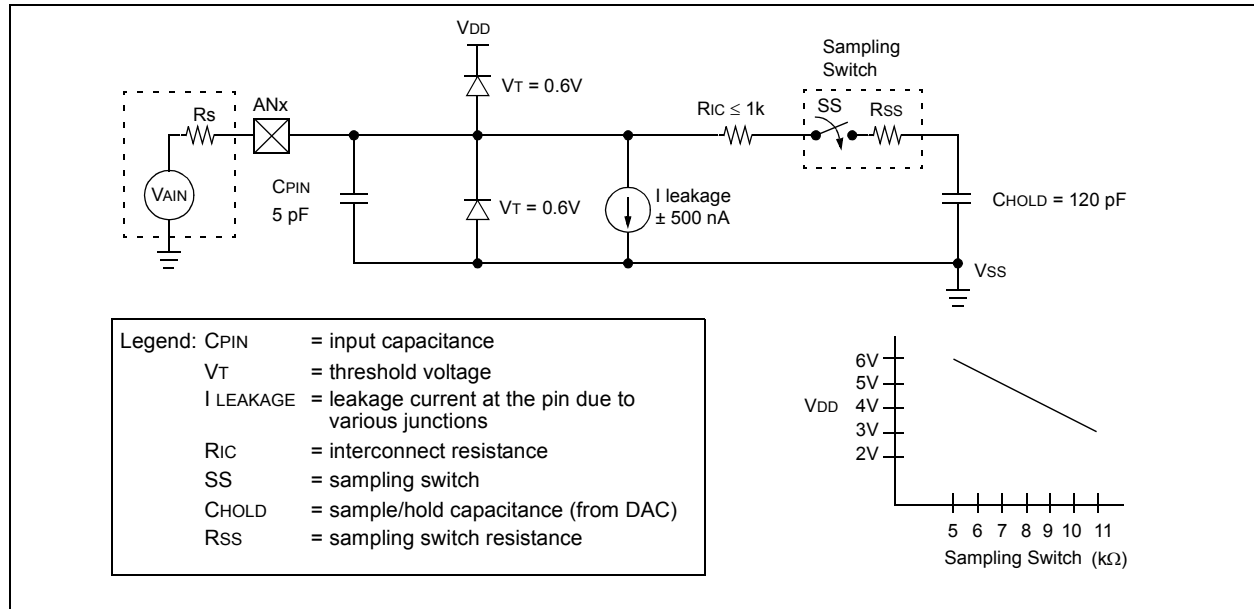

PIC18F1220/1320

17.1 A/D Acquisition Requirements

For the A/D converter to meet its specified accuracy, the charge holding capacitor (CHOLD) must be allowed to fully charge to the input channel voltage level. The analog input model is shown in Figure 17-2. The source impedance (Rs) and the internal sampling switch (Rss) impedance directly affect the time required to charge the capacitor CHOLD. The sampling switch (Rss) impedance varies over the device voltage (VDD). The source impedance affects the offset voltage at the analog input (due to pin leakage current). **The maximum recommended impedance for analog sources is 2.5kΩ.** After the analog input channel is selected (changed), the channel must be sampled for at least the minimum acquisition time before starting a conversion.

Note: When the conversion is started, the holding capacitor is disconnected from the input pin.

To calculate the minimum acquisition time, Equation 17-1 may be used. This equation assumes that 1/2 LSb error is used (1024 steps for the A/D). The 1/2 LSb error is the maximum error allowed for the A/D to meet its specified resolution.

Example 17-1 shows the calculation of the minimum required acquisition time TACQ. This calculation is based on the following application system assumptions:

- CHOLD = 120 pF
- Rs = 2.5 kΩ
- Conversion Error ≤ 1/2 LSb
- VDD = 5V → Rss = 7 kΩ
- Temperature = 50°C (system max.)
- VHOLD = 0V @ time = 0

17.2 A/D VREF+ and VREF- References

If external voltage references are used instead of the internal AVDD and AVSS sources, the source impedance of the VREF+ and VREF- voltage sources must be considered. During acquisition, currents supplied by these sources are insignificant. However, during conversion, the A/D module sinks and sources current through the reference sources.

In order to maintain the A/D accuracy, the voltage reference source impedances should be kept low to reduce voltage changes. These voltage changes occur as reference currents flow through the reference source impedance. **The maximum recommended impedance of the VREF+ and VREF- external reference voltage sources is 250Ω.**

EQUATION 17-1: ACQUISITION TIME

$$TACQ = \text{Amplifier Settling Time} + \text{Holding Capacitor Charging Time} + \text{Temperature Coefficient}$$

$$= TAMP + TC + TCOFF$$

EQUATION 17-2: A/D MINIMUM CHARGING TIME

$$VHOLD = (\Delta VREF - (\Delta VREF/2048)) \cdot (1 - e^{-(Tc/CHOLD)(RIC + RSS + RS)})$$

or

$$TC = -(CHOLD)(RIC + RSS + RS) \ln(1/2048)$$

EXAMPLE 17-1: CALCULATING THE MINIMUM REQUIRED ACQUISITION TIME

$$TACQ = TAMP + TC + TCOFF$$

$$TAMP = 5 \mu s$$

$$TCOFF = (Temp - 25^\circ C)(0.05 \mu s/^\circ C)$$

$$= (50^\circ C - 25^\circ C)(0.05 \mu s/^\circ C)$$

$$= 1.25 \mu s$$

Temperature coefficient is only required for temperatures > 25°C. Below 25°C, TCOFF = 0 μs.

$$TC = -(CHOLD)(RIC + RSS + RS) \ln(1/2047) \mu s$$

$$= -(120 \text{ pF})(1 \text{ k}\Omega + 7 \text{ k}\Omega + 2.5 \text{ k}\Omega) \ln(0.0004883) \mu s$$

$$= 9.61 \mu s$$

$$TACQ = 5 \mu s + 1.25 \mu s + 9.61 \mu s$$

$$= 12.86 \mu s$$

17.3 Selecting and Configuring Automatic Acquisition Time

The ADCON2 register allows the user to select an acquisition time that occurs each time the $\overline{\text{GO/DONE}}$ bit is set.

When the $\overline{\text{GO/DONE}}$ bit is set, sampling is stopped and a conversion begins. The user is responsible for ensuring the required acquisition time has passed between selecting the desired input channel and setting the $\overline{\text{GO/DONE}}$ bit. This occurs when the ACQT2:ACQT0 bits (ADCON2<5:3>) remain in their RESET state ('000'), and is compatible with devices that do not offer programmable acquisition times.

If desired, the ACQT bits can be set to select a programmable acquisition time for the A/D module. When the $\overline{\text{GO/DONE}}$ bit is set, the A/D module continues to sample the input for the selected acquisition time, then automatically begins a conversion. Since the acquisition time is programmed, there may be no need to wait for an acquisition time between selecting a channel and setting the $\overline{\text{GO/DONE}}$ bit.

In either case, when the conversion is completed, the $\overline{\text{GO/DONE}}$ bit is cleared, the ADIF flag is set, and the A/D begins sampling the currently selected channel again. If an acquisition time is programmed, there is nothing to indicate if the acquisition time has ended, or if the conversion has begun.

17.4 Selecting the A/D Conversion Clock

The A/D conversion time per bit is defined as T_{AD} . The A/D conversion requires 11 T_{AD} per 10-bit conversion. The source of the A/D conversion clock is software selectable. There are seven possible options for T_{AD} :

- 2 TOSC
- 4 TOSC
- 8 TOSC
- 16 TOSC
- 32 TOSC
- 64 TOSC
- Internal RC oscillator

For correct A/D conversions, the A/D conversion clock (T_{AD}) must be as short as possible, but greater than the minimum T_{AD} (approximately 2 μs , see parameter 130 for more information).

Table 17-1 shows the resultant T_{AD} times derived from the device operating frequencies and the A/D clock source selected.

TABLE 17-1: T_{AD} vs. DEVICE OPERATING FREQUENCIES

AD Clock Source (T_{AD})		Maximum Device Frequency	
Operation	ADCS2:ADCS0	PIC18F1X20	PIC18LF1X20 ⁽⁴⁾
2 TOSC	000	1.25 MHz	666 kHz
4 TOSC	100	2.50 MHz	1.33 MHz
8 TOSC	001	5.00 MHz	2.66 MHz
16 TOSC	101	10.0 MHz	5.33 MHz
32 TOSC	010	20.0 MHz	10.65 MHz
64 TOSC	110	40.0 MHz	21.33 MHz
RC ⁽³⁾	x11	1.00 MHz ⁽¹⁾	1.00 MHz ⁽²⁾

Note 1: The RC source has a typical T_{AD} time of 4 μs .

2: The RC source has a typical T_{AD} time of 6 μs .

3: For device frequencies above 1 MHz, the device must be in SLEEP for the entire conversion or the A/D accuracy may be out of specification.

4: Low power devices only.

PIC18F1220/1320

17.5 Operation in Low Power Modes

The selection of the automatic acquisition time and A/D conversion clock is determined, in part, by the Low Power mode clock source and frequency while in a Low Power mode.

If the A/D is expected to operate while the device is in a Low Power mode, the ACQT2:ACQT0 and ADCS2:ADCS0 bits in ADCON2 should be updated in accordance with the Low Power mode clock that will be used. After the Low Power mode is entered (either of the RUN modes), an A/D acquisition or conversion may be started. Once an acquisition or conversion is started, the device should continue to be clocked by the same Low Power mode clock source until the conversion has been completed. If desired, the device may be placed into the corresponding Low Power (ANY)_IDLE mode during the conversion.

If the Low Power mode clock frequency is less than 1 MHz, the A/D RC clock source should be selected.

Operation in the Low Power SLEEP mode requires the A/D RC clock to be selected. If bits ACQT2:ACQT0 are set to '000', and a conversion is started, the conversion will be delayed one instruction cycle to allow execution of the SLEEP instruction and entry to Low Power SLEEP mode. The IDLEN and SCS bits in the OSCCON register must have already been cleared prior to starting the conversion.

17.6 Configuring Analog Port Pins

The ADCON1, TRISA, and TRISB registers all configure the A/D port pins. The port pins needed as analog inputs must have their corresponding TRIS bits set (input). If the TRIS bit is cleared (output), the digital output level (VOH or VOL) will be converted.

The A/D operation is independent of the state of the CHS2:CHS0 bits and the TRIS bits.

Note 1: When reading the port register, all pins configured as analog input channels will read as cleared (a low level). Pins configured as digital inputs will convert an analog input. Analog levels on a digitally configured input will be accurately converted.

2: Analog levels on any pin defined as a digital input may cause the digital input buffer to consume current out of the device's specification limits.

17.7 A/D Conversions

Figure 17-3 shows the operation of the A/D converter after the GO bit has been set and the ACQT2:ACQT0 bits are cleared. A conversion is started after the following instruction to allow entry into Low Power SLEEP mode before the conversion begins.

Figure 17-4 shows the operation of the A/D converter after the GO bit has been set and the ACQT2:ACQT0 bits are set to '010', and selecting a 4 TAD acquisition time before the conversion starts.

Clearing the $\overline{\text{GO/DONE}}$ bit during a conversion will abort the current conversion. The A/D result register pair will NOT be updated with the partially completed A/D conversion sample. This means the ADRESH:ADRESL registers will continue to contain the value of the last completed conversion (or the last value written to the ADRESH:ADRESL registers).

After the A/D conversion is completed or aborted, a 2 TAD wait is required before the next acquisition can be started. After this wait, acquisition on the selected channel is automatically started.

Note: The $\overline{\text{GO/DONE}}$ bit should **NOT** be set in the same instruction that turns on the A/D.

FIGURE 17-3: A/D CONVERSION TAD CYCLES (ACQT<2:0> = 000, TACQ = 0)

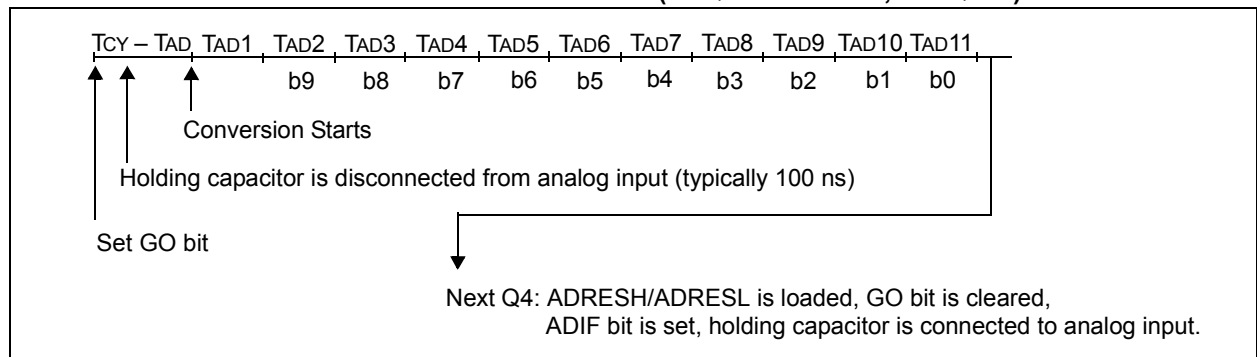
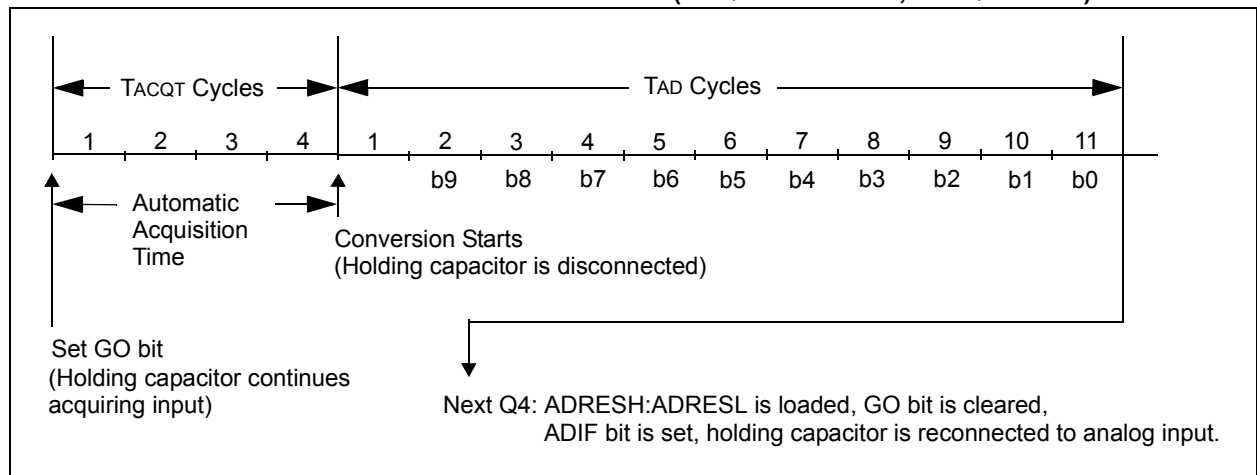

FIGURE 17-4: A/D CONVERSION TAD CYCLES (ACQT<2:0> = 010, TACQ = 4 TAD)



PIC18F1220/1320

17.8 Use of the CCP1 Trigger

An A/D conversion can be started by the “special event trigger” of the CCP1 module. This requires that the CCP1M3:CCP1M0 bits (CCP1CON<3:0>) be programmed as ‘1011’ and that the A/D module is enabled (ADON bit is set). When the trigger occurs, the GO/DONE bit will be set, starting the A/D acquisition and conversion, and the Timer1 (or Timer3) counter will be reset to zero. Timer1 (or Timer3) is reset to automatically repeat the A/D acquisition period with minimal software overhead (moving ADRESH/ADRESL to the

desired location). The appropriate analog input channel must be selected and the minimum acquisition period is either timed by the user, or an appropriate TACQ time selected before the “special event trigger” sets the GO/DONE bit (starts a conversion).

If the A/D module is not enabled (ADON is cleared), the “special event trigger” will be ignored by the A/D module, but will still reset the Timer1 (or Timer3) counter.

TABLE 17-2: SUMMARY OF A/D REGISTERS

Name	Bit 7	Bit 6	Bit 5	Bit 4	Bit 3	Bit 2	Bit 1	Bit 0	Value on POR, BOR	Value on all other RESETS	
INTCON	GIE/ GIEH	PEIE/ GIEL	TMR0IE	INT0IE	RBIE	TMR0IF	INT0IF	RBIF	0000 0000	0000 0000	
PIR1	—	ADIF	RCIF	TXIF	—	CCP1IF	TMR2IF	TMR1IF	-000 -000	-000 -000	
PIE1	—	ADIE	RCIE	TXIE	—	CCP1IE	TMR2IE	TMR1IE	-000 -000	-000 -000	
IPR1	—	ADIP	RCIP	TXIP	—	CCP1IP	TMR2IP	TMR1IP	-111 -111	-111 -111	
PIR2	OSCFIF	—	—	EEIF	—	LVDIF	TMR3IF	—	0--0 -00-	0--0 -00-	
PIE2	OSCFIE	—	—	EEIE	—	LVDIE	TMR3IE	—	0--0 -00-	0--0 -00-	
IPR2	OSCFIP	—	—	EEIP	—	LVDIP	TMR3IP	—	1--1 -11-	1--1 -11-	
ADRESH	A/D Result Register High Byte								xxxx xxxx	uuuu uuuu	
ADRESL	A/D Result Register Low Byte								xxxx xxxx	uuuu uuuu	
ADCON0	VCFG1	VCFG0	—	CHS2	CHS1	CHS0	GO/DONE	ADON	00-0 0000	00-0 0000	
ADCON1	—	PCFG6	PCFG5	PCFG4	PCFG3	PCFG2	PCFG1	PCFG0	-000 0000	-000 0000	
ADCON2	ADFM	—	ACQT2	ACQT1	ACQT0	ADCS2	ADCS1	ADCS0	0-00 0000	0-00 0000	
PORTA	RA7	RA6	RA5 ⁽¹⁾	RA4	RA3	RA2	RA1	RA0	--0x 0000	--0u 0000	
TRISA	TRISA7	TRISA6	—	PORTA Data Direction Register						11-1 1111	11-1 1111
PORTB	Read PORTB pins, Write LATB Latch								xxxx xxxx	uuuu uuuu	
TRISB	PORTB Data Direction Register								1111 1111	1111 1111	
LATB	PORTB Output Data Latch								xxxx xxxx	uuuu uuuu	

Legend: x = unknown, u = unchanged, - = unimplemented, read as '0', q = value depends on condition.
Shaded cells are not used for A/D conversion.

Note 1: RA5 port bit is available only as an input pin when MCLRE bit in configuration register is '0'.

18.0 LOW VOLTAGE DETECT

In many applications, the ability to determine if the device voltage (VDD) is below a specified voltage level is a desirable feature. A window of operation for the application can be created, where the application software can do “housekeeping tasks”, before the device voltage exits the valid operating range. This can be done using the Low Voltage Detect module.

This module is a software programmable circuitry, where a device voltage trip point can be specified. When the voltage of the device becomes lower than the specified point, an interrupt flag is set. If the interrupt is enabled, the program execution will branch to the interrupt vector address and the software can then respond to that interrupt source.

The Low Voltage Detect circuitry is completely under software control. This allows the circuitry to be turned off by the software, which minimizes the current consumption for the device.

Figure 18-1 shows a possible application voltage curve (typically for batteries). Over time, the device voltage decreases. When the device voltage equals voltage VA, the LVD logic generates an interrupt. This occurs at time TA. The application software then has the time, until the device voltage is no longer in valid operating range, to shutdown the system. Voltage point VB is the minimum valid operating voltage specification. This occurs at time TB. The difference TB – TA is the total time for shutdown.

The block diagram for the LVD module is shown in Figure 18-2 (following page). A comparator uses an internally generated reference voltage as the set point. When the selected tap output of the device voltage crosses the set point (is lower than), the LVDIF bit is set.

Each node in the resistor divider represents a “trip point” voltage. The “trip point” voltage is the minimum supply voltage level at which the device can operate before the LVD module asserts an interrupt. When the supply voltage is equal to the trip point, the voltage tapped off of the resistor array is equal to the 1.2V internal reference voltage generated by the voltage reference module. The comparator then generates an interrupt signal setting the LVDIF bit. This voltage is software programmable to any one of 16 values (see Figure 18-2). The trip point is selected by programming the LVDL3:LVDL0 bits (LVDCON<3:0>).

FIGURE 18-1: TYPICAL LOW VOLTAGE DETECT APPLICATION

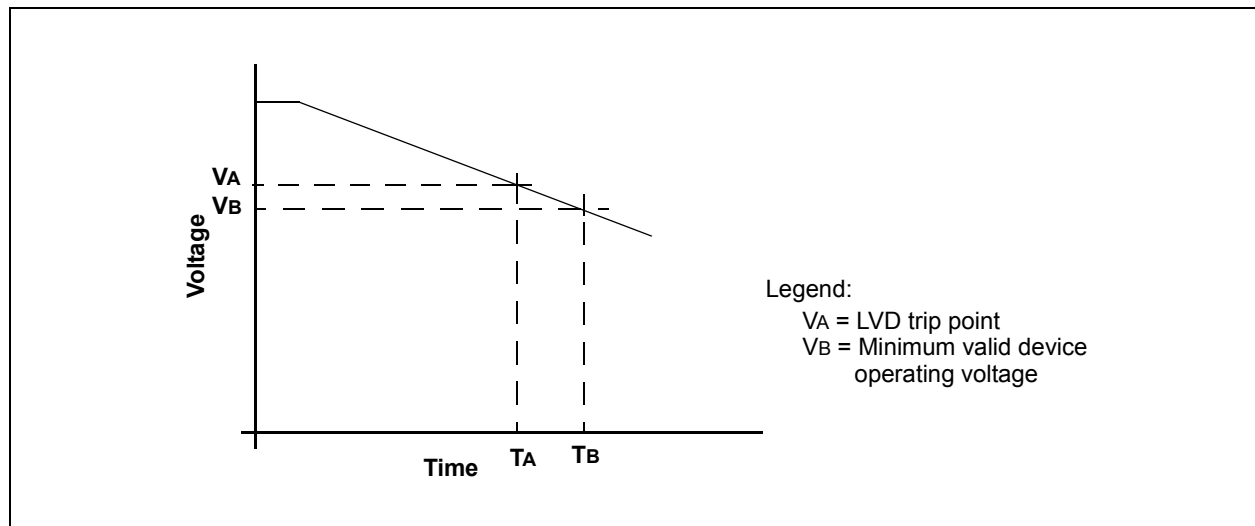

PIC18F1220/1320

FIGURE 18-2: LOW VOLTAGE DETECT (LVD) BLOCK DIAGRAM

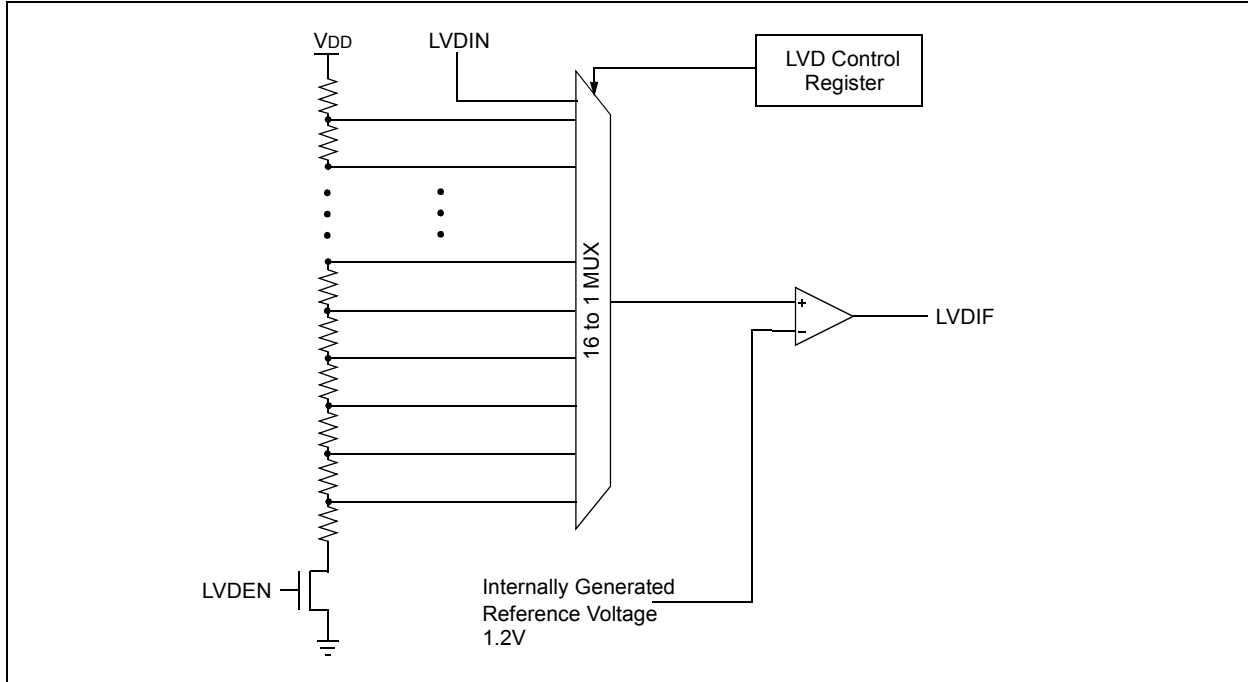

The LVD module has an additional feature that allows the user to supply the trip voltage to the module from an external source. This mode is enabled when bits LVDL3:LVDL0 are set to '1111'. In this state, the comparator input is multiplexed from the external input pin,

LVDIN (Figure 18-3). This gives users flexibility, because it allows them to configure the Low Voltage Detect interrupt to occur at any voltage in the valid operating range.

FIGURE 18-3: LOW VOLTAGE DETECT (LVD) WITH EXTERNAL INPUT BLOCK DIAGRAM

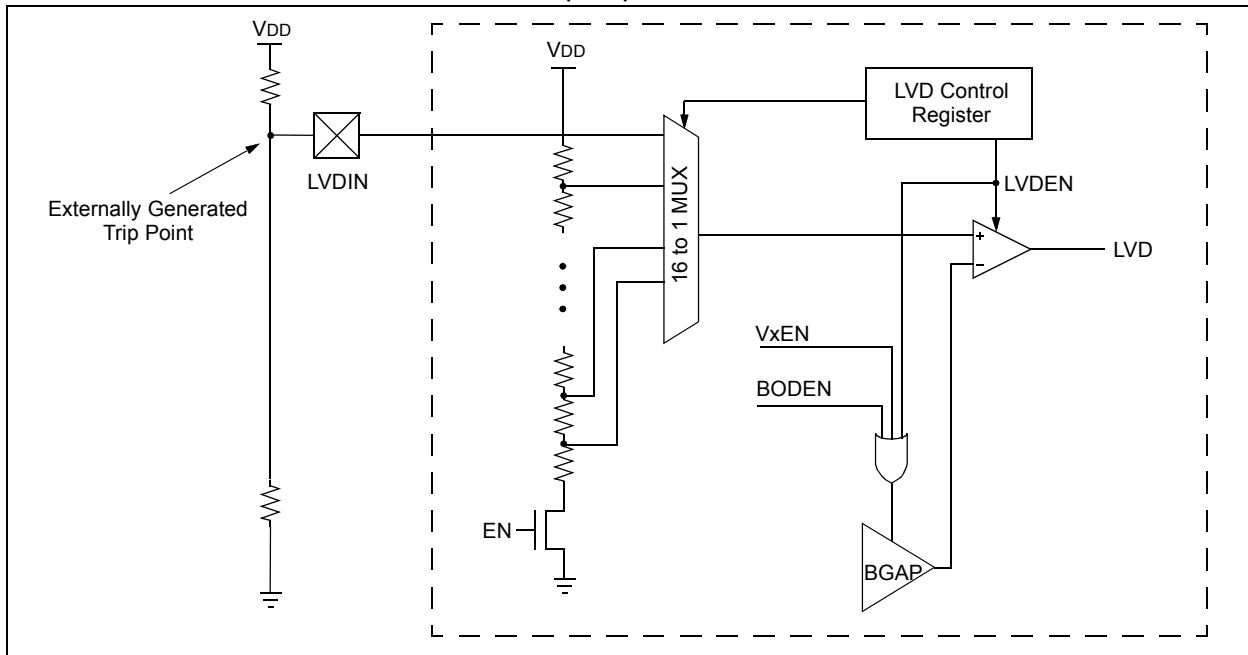

18.1 Control Register

The Low Voltage Detect Control register controls the operation of the Low Voltage Detect circuitry.

REGISTER 18-1: LVDCON REGISTER

U-0	U-0	R-0	R/W-0	R/W-0	R/W-1	R/W-0	R/W-1	
—	—	IRVST	LVDEN	LVDL3	LVDL2	LVDL1	LVDL0	
bit 7								bit 0

bit 7-6 **Unimplemented:** Read as '0'

bit 5 **IRVST:** Internal Reference Voltage Stable Flag bit

1 = Indicates that the Low Voltage Detect logic will generate the interrupt flag at the specified voltage range

0 = Indicates that the Low Voltage Detect logic will not generate the interrupt flag at the specified voltage range and the LVD interrupt should not be enabled

bit 4 **LVDEN:** Low Voltage Detect Power Enable bit

1 = Enables LVD, powers up LVD circuit

0 = Disables LVD, powers down LVD circuit

bit 3-0 **LVDL3:LVDL0:** Low Voltage Detection Limit bits

1111 = External analog input is used (input comes from the LVDIN pin)

1110 = 4.50V - 4.78V

1101 = 4.20V - 4.46V

1100 = 4.00V - 4.26V

1011 = 3.80V - 4.04V

1010 = 3.60V - 3.84V

1001 = 3.50V - 3.72V

1000 = 3.30V - 3.52V

0111 = 3.00V - 3.20V

0110 = 2.80V - 2.98V

0101 = 2.70V - 2.86V

0100 = 2.50V - 2.66V

0011 = 2.40V - 2.55V

0010 = 2.20V - 2.34V

0001 = 2.00V - 2.12V

0000 = Reserved

Note: LVDL3:LVDL0 modes, which result in a trip point below the valid operating voltage of the device, are not tested.

Legend:

R = Readable bit

W = Writable bit

U = Unimplemented bit, read as '0'

- n = Value at POR

'1' = Bit is set

'0' = Bit is cleared

x = Bit is unknown

PIC18F1220/1320

18.2 Operation

Depending on the power source for the device voltage, the voltage normally decreases relatively slowly. This means that the LVD module does not need to be constantly operating. To decrease the current requirements, the LVD circuitry only needs to be enabled for short periods, where the voltage is checked. After doing the check, the LVD module may be disabled.

Each time that the LVD module is enabled, the circuitry requires some time to stabilize. After the circuitry has stabilized, all status flags may be cleared. The module will then indicate the proper state of the system.

The following steps are needed to set up the LVD module:

1. Write the value to the LVDL3:LVDL0 bits (LVDCON register), which selects the desired LVD Trip Point.
2. Ensure that LVD interrupts are disabled (the LVDIE bit is cleared or the GIE bit is cleared).
3. Enable the LVD module (set the LVDEN bit in the LVDCON register).
4. Wait for the LVD module to stabilize (the IRVST bit to become set).
5. Clear the LVD interrupt flag, which may have falsely become set until the LVD module has stabilized (clear the LVDIF bit).
6. Enable the LVD interrupt (set the LVDIE and the GIE bits).

Figure 18-4 shows typical waveforms that the LVD module may be used to detect.

FIGURE 18-4: LOW VOLTAGE DETECT WAVEFORMS

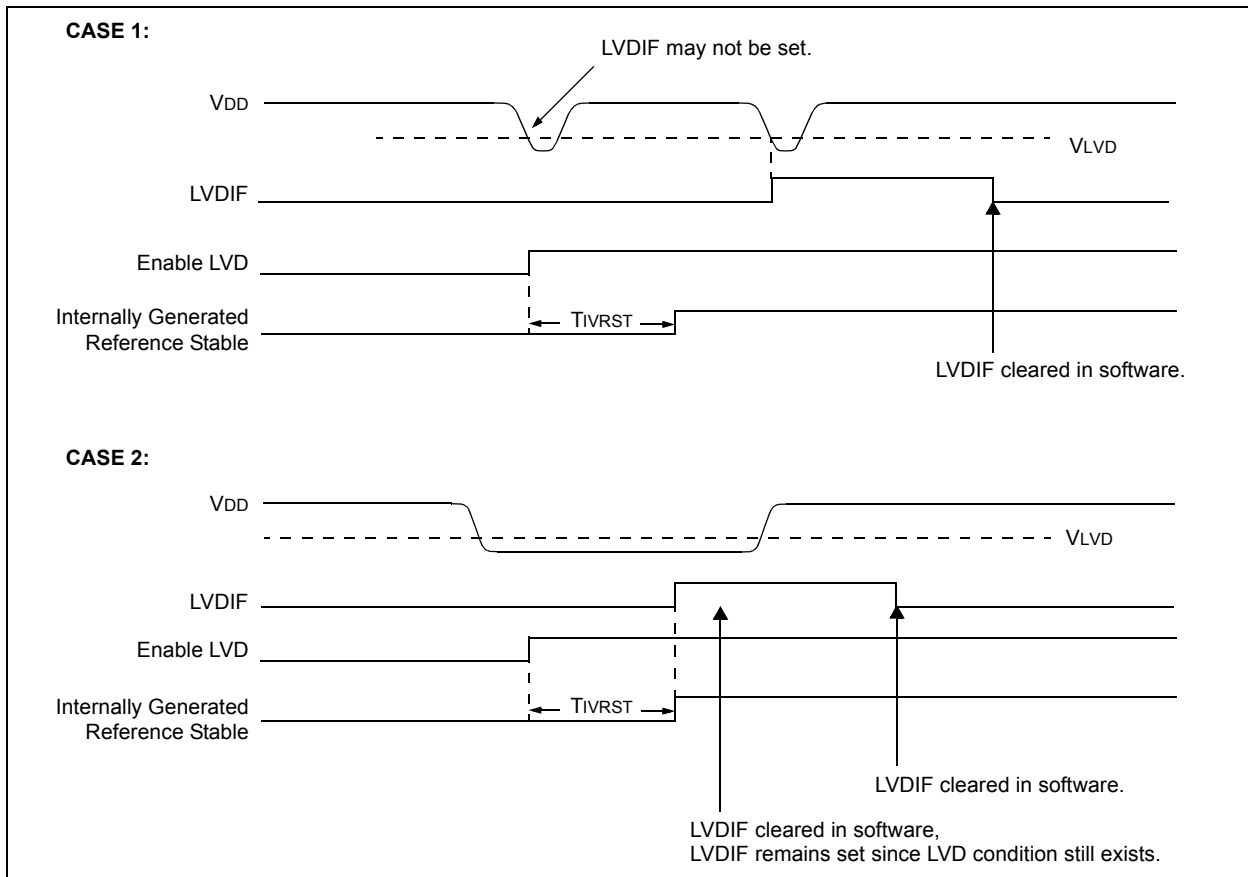

18.2.1 REFERENCE VOLTAGE SET POINT

The Internal Reference Voltage of the LVD module may be used by other internal circuitry (the Programmable Brown-out Reset). If these circuits are disabled (lower current consumption), the reference voltage circuit requires a time to become stable before a low voltage condition can be reliably detected. This time is invariant of system clock speed. This start-up time is specified in electrical specification parameter 36. The low voltage interrupt flag will not be enabled until a stable reference voltage is reached. Refer to the waveform in Figure 18-4.

18.2.2 CURRENT CONSUMPTION

When the module is enabled, the LVD comparator and voltage divider are enabled and will consume static current. The voltage divider can be tapped from multiple places in the resistor array. Total current consumption, when enabled, is specified in electrical specification parameter #D022B.

18.3 Operation During SLEEP

When enabled, the LVD circuitry continues to operate during SLEEP. If the device voltage crosses the trip point, the LVDIF bit will be set and the device will wake-up from SLEEP. Device execution will continue from the interrupt vector address, if interrupts have been globally enabled.

18.4 Effects of a RESET

A device RESET forces all registers to their RESET state. This forces the LVD module to be turned off.

PIC18F1220/1320

NOTES:

19.0 SPECIAL FEATURES OF THE CPU

PIC18F1220/1320 devices include several features intended to maximize system reliability, minimize cost through elimination of external components and offer code protection. These are:

- Oscillator Selection
- RESETS:
 - Power-on Reset (POR)
 - Power-up Timer (PWRT)
 - Oscillator Start-up Timer (OST)
 - Brown-out Reset (BOR)
- Interrupts
- Watchdog Timer (WDT)
- Fail-Safe Clock Monitor
- Two-Speed Start-up
- Code Protection
- ID Locations
- In-Circuit Serial Programming

Several oscillator options are available to allow the part to fit the application. The RC oscillator option saves system cost, while the LP crystal option saves power. These are discussed in detail in Section 2.0.

A complete discussion of device RESETS and interrupts is available in previous sections of this data sheet.

In addition to their Power-up and Oscillator Start-up Timers provided for RESETS, PIC18F1220/1320 devices have a Watchdog Timer, which is either permanently enabled via the configuration bits, or software controlled (if configured as disabled).

The inclusion of an internal RC oscillator also provides the additional benefits of a Fail-Safe Clock Monitor (FSCM) and Two-Speed Start-up. FSCM provides for background monitoring of the peripheral clock and automatic switchover in the event of its failure. Two-Speed Start-up enables code to be executed almost immediately on start-up, while the primary clock source completes its start-up delays.

All of these features are enabled and configured by setting the appropriate configuration register bits.

19.1 Configuration Bits

The configuration bits can be programmed (read as '0'), or left unprogrammed (read as '1'), to select various device configurations. These bits are mapped starting at program memory location 300000h.

The user will note that address 300000h is beyond the user program memory space. In fact, it belongs to the configuration memory space (300000h - 3FFFFFFh), which can only be accessed using Table Reads and Table Writes.

Programming the configuration registers is done in a manner similar to programming the FLASH memory. The EECON1 register WR bit starts a self-timed write to the configuration register. In normal Operation mode, a TBLWT instruction, with the TBLPTR pointing to the configuration register, sets up the address and the data for the configuration register write. Setting the WR bit starts a long write to the configuration register. The configuration registers are written a byte at a time. To write or erase a configuration cell, a TBLWT instruction can write a '1' or a '0' into the cell. For additional details on FLASH programming, refer to Section 6.5.

TABLE 19-1: CONFIGURATION BITS AND DEVICE IDS

File Name	Bit 7	Bit 6	Bit 5	Bit 4	Bit 3	Bit 2	Bit 1	Bit 0	Default/ Unprogrammed Value
300001h CONFIG1H	IESO	FCMEN	—	—	FOSC3	FOSC2	FOSC1	FOSC0	11-- 1111
300002h CONFIG2L	—	—	—	—	BORV1	BORV0	BODEN	PWRTEN	---- 1111
300003h CONFIG2H	—	—	—	WDTPS3	WDTPS2	WDTPS1	WDTPS0	WDTEN	---1 1111
300005h CONFIG3H	MCLRE	—	—	—	—	—	—	—	1--- ----
300006h CONFIG4L	DEBUG	—	—	—	—	LVP	—	STVREN	1--- -1-1
300008h CONFIG5L	—	—	—	—	—	—	CP1	CP0	---- --11
300009h CONFIG5H	CPD	CPB	—	—	—	—	—	—	11-- ----
30000Ah CONFIG6L	—	—	—	—	—	—	WRT1	WRT0	---- --11
30000Bh CONFIG6H	WRWD	WRWB	WRWC	—	—	—	—	—	111- ----
30000Ch CONFIG7L	—	—	—	—	—	—	EBTR1	EBTR0	---- --11
30000Dh CONFIG7H	—	EBTRB	—	—	—	—	—	—	-1-- ----
3FFFFFFh DEVID1 ⁽¹⁾	DEV2	DEV1	DEV0	REV4	REV3	REV2	REV1	REV0	xxxx xxxx ⁽¹⁾
3FFFFFFh DEVID2 ⁽¹⁾	DEV10	DEV9	DEV8	DEV7	DEV6	DEV5	DEV4	DEV3	0000 0111

Legend: x = unknown, u = unchanged, - = unimplemented, q = value depends on condition.
Shaded cells are unimplemented, read as '0'.

Note 1: See Register 19-14 for DEVID1 values. DEVID registers are read only and cannot be programmed by the user.

PIC18F1220/1320

REGISTER 19-1: CONFIGURATION REGISTER 1 HIGH (CONFIG1H: BYTE ADDRESS 300001h)

R/P-1	R/P-1	U-0	U-0	R/P-1	R/P-1	R/P-1	R/P-1
IESO	FCMEN	—	—	FOSC3	FOSC2	FOSC1	FOSC0

bit 7

bit 0

- bit 7 **IESO:** Internal External Switch Over bit
1 = Internal External Switch Over mode enabled
0 = Internal External Switch Over mode disabled
- bit 6 **FCMEN:** Fail-Safe Clock Monitor Enable bit
1 = Fail-Safe Clock Monitor enabled
0 = Fail-Safe Clock Monitor disabled
- bit 5:4 **Unimplemented:** Read as '0'
- bit 3-0 **FOSC<3:0>:** Oscillator Selection bits
11xx = External RC oscillator, CLKO function on RA6
1001 = Internal RC oscillator, CLKO function on RA6, and port function on RA7
1000 = Internal RC oscillator, port function on RA6, and port function on RA7
0111 = External RC oscillator, port function on RA6
0110 = HS oscillator, PLL enabled (clock frequency = 4 x Fosc1)
0101 = EC oscillator, port function on RA6
0100 = EC oscillator, CLKO function on RA6
0010 = HS oscillator
0001 = XT oscillator
0000 = LP oscillator

Legend:

R = Readable bit P = Programmable bit U = Unimplemented bit, read as '0'
- n = Value when device is unprogrammed u = Unchanged from programmed state

REGISTER 19-2: CONFIGURATION REGISTER 2 LOW (CONFIG2L: BYTE ADDRESS 300002h)

U-0	U-0	U-0	U-0	R/P-1	R/P-1	R/P-1	R/P-1
—	—	—	—	BORV1	BORV0	BOREN	PWRTEN
bit 7				bit 0			

- bit 7-4 **Unimplemented:** Read as '0'
- bit 3-2 **BORV1:BORV0:** Brown-out Reset Voltage bits
 11 = VBOR set to 2.0V
 10 = VBOR set to 2.7V
 01 = VBOR set to 4.2V
 00 = VBOR set to 4.5V
- bit 1 **BOREN:** Brown-out Reset Enable bit⁽¹⁾
 1 = Brown-out Reset enabled
 0 = Brown-out Reset disabled
- bit 0 **PWRTEN:** Power-up Timer Enable bit⁽¹⁾
 1 = PWRT disabled
 0 = PWRT enabled

Note 1: The Power-up Timer is decoupled from Brown-out Reset, allowing these features to be independently controlled.

Legend:

R = Readable bit P = Programmable bit U = Unimplemented bit, read as '0'
 - n = Value when device is unprogrammed u = Unchanged from programmed state

PIC18F1220/1320

REGISTER 19-3: CONFIGURATION REGISTER 2 HIGH (CONFIG2H: BYTE ADDRESS 300003h)

U-0	U-0	U-0	R/P-1	R/P-1	R/P-1	R/P-1	R/P-1	
—	—	—	WDTPS3	WDTPS2	WDTPS1	WDTPS0	WDTEN	
bit 7								bit 0

bit 7-5 **Unimplemented:** Read as '0'

bit 4-1 **WDPS<3:0>:** Watchdog Timer Postscale Select bits

1111 = 1:32,768
1110 = 1:16,384
1101 = 1:8,192
1100 = 1:4,096
1011 = 1:2,048
1010 = 1:1,024
1001 = 1:512
1000 = 1:256
0111 = 1:128
0110 = 1:64
0101 = 1:32
0100 = 1:16
0011 = 1:8
0010 = 1:4
0001 = 1:2
0000 = 1:1

bit 0 **WDTEN:** Watchdog Timer Enable bit

1 = WDT enabled

0 = WDT disabled (control is placed on the SWDTEN bit)

Legend:

R = Readable bit

P = Programmable bit

U = Unimplemented bit, read as '0'

- n = Value when device is unprogrammed

u = Unchanged from programmed state

REGISTER 19-4: CONFIGURATION REGISTER 3 HIGH (CONFIG3H: BYTE ADDRESS 300005h)

R/P-1	U-0	U-0	U-0	U-0	U-0	U-0	U-0
MCLRE	—	—	—	—	—	—	—
bit 7							bit 0

- bit 7 **MCLRE:** $\overline{\text{MCLR}}$ Pin Enable bit
 1 = $\overline{\text{MCLR}}$ pin enabled, RA5 input pin disabled
 0 = RA5 input pin enabled, $\overline{\text{MCLR}}$ disabled
- bit 6-0 **Unimplemented:** Read as '0'

Legend:

R = Readable bit P = Programmable bit U = Unimplemented bit, read as '0'
 - n = Value when device is unprogrammed u = Unchanged from programmed state

REGISTER 19-5: CONFIGURATION REGISTER 4 LOW (CONFIG4L: BYTE ADDRESS 300006h)

R/P-1	U-0	U-0	U-0	U-0	R/P-1	U-0	R/P-1
$\overline{\text{DEBUG}}$	—	—	—	—	LVP	—	STVREN
bit 7							bit 0

- bit 7 **$\overline{\text{DEBUG}}$:** Background Debugger Enable bit
 1 = Background Debugger disabled, RB6 and RB7 configured as general purpose I/O pins
 0 = Background Debugger enabled, RB6 and RB7 are dedicated to In-Circuit Debug
- bit 6-3 **Unimplemented:** Read as '0'
- bit 2 **LVP:** Low Voltage ICSP Enable bit
 1 = Low Voltage ICSP enabled
 0 = Low Voltage ICSP disabled
- bit 1 **Unimplemented:** Read as '0'
- bit 0 **STVREN:** Stack Full/Underflow Reset Enable bit
 1 = Stack Full/Underflow will cause RESET
 0 = Stack Full/Underflow will not cause RESET

Legend:

R = Readable bit C = Clearable bit U = Unimplemented bit, read as '0'
 - n = Value when device is unprogrammed u = Unchanged from programmed state

PIC18F1220/1320

REGISTER 19-6: CONFIGURATION REGISTER 5 LOW (CONFIG5L: BYTE ADDRESS 300008h)

U-0	U-0	U-0	U-0	R/C-1	R/C-1	R/C-1	R/C-1
—	—	—	—	—	—	CP1	CP0
bit 7						bit 0	

bit 7-2 **Unimplemented:** Read as '0'

bit 1 **CP1:** Code Protection bit (PIC18F1320)
 1 = Block 1 (001000-001FFFh) not code protected
 0 = Block 1 (001000-001FFFh) code protected

bit 0 **CP0:** Code Protection bit (PIC18F1320)
 1 = Block 0 (00200-000FFFh) not code protected
 0 = Block 0 (00200-000FFFh) code protected

bit 1 **CP1:** Code Protection bit (PIC18F1220)
 1 = Block 1 (000800-000FFFh) not code protected
 0 = Block 1 (000800-000FFFh) code protected

bit 0 **CP0:** Code Protection bit (PIC18F1220)
 1 = Block 0 (000200-0007FFh) not code protected
 0 = Block 0 (000200-0007FFh) code protected

Legend:

R = Readable bit C = Clearable bit U = Unimplemented bit, read as '0'
 - n = Value when device is unprogrammed u = Unchanged from programmed state

REGISTER 19-7: CONFIGURATION REGISTER 5 HIGH (CONFIG5H: BYTE ADDRESS 300009h)

R/C-1	R/C-1	U-0	U-0	U-0	U-0	U-0	U-0
CPD	CPB	—	—	—	—	—	—
bit 7						bit 0	

bit 7 **CPD:** Data EEPROM Code Protection bit
 1 = Data EEPROM not code protected
 0 = Data EEPROM code protected

bit 6 **CPB:** Boot Block Code Protection bit
 1 = Boot Block (000000-0001FFFh) not code protected
 0 = Boot Block (000000-0001FFFh) code protected

bit 5-0 **Unimplemented:** Read as '0'

Legend:

R = Readable bit C = Clearable bit U = Unimplemented bit, read as '0'
 - n = Value when device is unprogrammed u = Unchanged from programmed state

REGISTER 19-8: CONFIGURATION REGISTER 6 LOW (CONFIG6L: BYTE ADDRESS 30000Ah)

U-0	U-0	U-0	U-0	U-0	U-0	R/P-1	R/P-1
—	—	—	—	—	—	WRT1	WRT0
bit 7						bit 0	

- bit 7-2 **Unimplemented:** Read as '0'
- bit 1 **WRT1:** Write Protection bit (PIC18F1320)
 1 = Block 1 (001000-001FFFh) not write protected
 0 = Block 1 (001000-001FFFh) write protected
- bit 0 **WRT0:** Write Protection bit (PIC18F1320)
 1 = Block 0 (00200-000FFFh) not write protected
 0 = Block 0 (00200-000FFFh) write protected
- bit 1 **WRT1:** Write Protection bit (PIC18F1220)
 1 = Block 1 (000800-000FFFh) not write protected
 0 = Block 1 (000800-000FFFh) write protected
- bit 0 **WRT0:** Write Protection bit (PIC18F1220)
 1 = Block 0 (000200-0007FFh) not write protected
 0 = Block 0 (000200-0007FFh) write protected

Legend:		
R = Readable bit	P = Programmable bit	U = Unimplemented bit, read as '0'
- n = Value when device is unprogrammed	u = Unchanged from programmed state	

REGISTER 19-9: CONFIGURATION REGISTER 6 HIGH (CONFIG6H: BYTE ADDRESS 30000Bh)

R/P-1	R/P-1	R-1	U-0	U-0	U-0	U-0	U-0
WRTD	WRTB	WRTC	—	—	—	—	—
bit 7			bit 0				

- bit 7 **WRTD:** Data EEPROM Write Protection bit
 1 = Data EEPROM not write protected
 0 = Data EEPROM write protected
- bit 6 **WRTB:** Boot Block Write Protection bit
 1 = Boot Block (000000-0001FFh) not write protected
 0 = Boot Block (000000-0001FFh) write protected
- bit 5 **WRTC:** Configuration Register Write Protection bit
 1 = Configuration registers (300000-3000FFh) not write protected
 0 = Configuration registers (300000-3000FFh) write protected
- Note:** This bit is read only in normal Execution mode; it can be written only in Program mode.
- bit 4-0 **Unimplemented:** Read as '0'

Legend:		
R = Readable bit	P = Programmable bit	U = Unimplemented bit, read as '0'
- n = Value when device is unprogrammed	u = Unchanged from programmed state	

PIC18F1220/1320

REGISTER 19-10: CONFIGURATION REGISTER 7 LOW (CONFIG7L: BYTE ADDRESS 30000Ch)

U-0	U-0	U-0	U-0	U-0	U-0	R/P-1	R/P-1
—	—	—	—	—	—	EBTR1	EBTR0
bit 7						bit 0	

bit 7-2 **Unimplemented:** Read as '0'

bit 1 **EBTR1:** Table Read Protection bit (PIC18F1320)

1 = Block 1 (001000-001FFFh) not protected from Table Reads executed in other blocks
 0 = Block 1 (001000-001FFFh) protected from Table Reads executed in other blocks

bit 0 **EBTR0:** Table Read Protection bit (PIC18F1320)

1 = Block 0 (00200-000FFFh) not protected from Table Reads executed in other blocks
 0 = Block 0 (00200-000FFFh) protected from Table Reads executed in other blocks

bit 1 **EBTR1:** Table Read Protection bit (PIC18F1220)

1 = Block 1 (000800-000FFFh) not protected from Table Reads executed in other blocks
 0 = Block 1 (000800-000FFFh) protected from Table Reads executed in other blocks

bit 0 **EBTR0:** Table Read Protection bit (PIC18F1220)

1 = Block 0 (000200-0007FFh) not protected from Table Reads executed in other blocks
 0 = Block 0 (000200-0007FFh) protected from Table Reads executed in other blocks

Legend:

R = Readable bit P = Programmable bit U = Unimplemented bit, read as '0'
 - n = Value when device is unprogrammed u = Unchanged from programmed state

REGISTER 19-11: CONFIGURATION REGISTER 7 HIGH (CONFIG7H: BYTE ADDRESS 30000Dh)

U-0	R/P-1	U-0	U-0	U-0	U-0	U-0	U-0
—	EBTRB	—	—	—	—	—	—
bit 7						bit 0	

bit 7 **Unimplemented:** Read as '0'

bit 6 **EBTRB:** Boot Block Table Read Protection bit

1 = Boot Block (000000-0001FFFh) not protected from Table Reads executed in other blocks
 0 = Boot Block (000000-0001FFFh) protected from Table Reads executed in other blocks

bit 5-0 **Unimplemented:** Read as '0'

Legend:

R = Readable bit P = Programmable bit U = Unimplemented bit, read as '0'
 - n = Value when device is unprogrammed u = Unchanged from programmed state

REGISTER 19-12: DEVICE ID REGISTER 1 FOR PIC18F1220/1320 DEVICES

R	R	R	R	R	R	R	R	
DEV2	DEV1	DEV0	REV4	REV3	REV2	REV1	REV0	
bit 7								bit 0

bit 7-5 **DEV2:DEV0:** Device ID bits

111 = PIC18F1220

110 = PIC18F1320

bit 4-0 **REV4:REV0:** Revision ID bits

These bits are used to indicate the device revision

Legend:

R = Read only bit P = Programmable bit U = Unimplemented bit, read as '0'
 - n = Value when device is unprogrammed u = Unchanged from programmed state

REGISTER 19-13: DEVICE ID REGISTER 2 FOR PIC18F1220/1320 DEVICES

R	R	R	R	R	R	R	R	
DEV10	DEV9	DEV8	DEV7	DEV6	DEV5	DEV4	DEV3	
bit 7								bit 0

bit 7-0 **DEV10:DEV3:** Device ID bits

These bits are used with the DEV2:DEV0 bits in the Device ID Register 1 to identify the part number

0000 0111 = PIC18F1220/1320 devices

Note: These values for DEV10:DEV3 may be shared with other devices. The specific device is always identified by using the entire DEV10:DEV0 bit sequence.

Legend:

R = Read only bit P = Programmable bit U = Unimplemented bit, read as '0'
 - n = Value when device is unprogrammed u = Unchanged from programmed state

PIC18F1220/1320

19.2 Watchdog Timer (WDT)

For PIC18F1220/1320 devices, the WDT is driven by the INTRC source. When the WDT is enabled, the clock source is also enabled. The nominal WDT period is 4 ms, and has the same stability as the INTRC oscillator.

The 4 ms period of the WDT is multiplied by a 16-bit postscaler. Any output of the WDT postscaler is selected by a multiplexer, controlled by bits in Configuration Register 2H. Available periods range from 4 ms to 131.072 seconds (2.18 minutes). The WDT and postscaler are cleared when any of the following events occur: execute a SLEEP or CLRWDT instruction, the IRCF bits (OSCCON<6:4>) are changed, or a clock failure has occurred.

Adjustments to the internal oscillator clock period using the OSTUNE register also affect the period of the WDT by the same factor. For example, if the INTRC period is increased by 3%, then the WDT period is increased by 3%.

Note 1: The CLRWDT and SLEEP instructions clear the WDT and postscaler counts when executed.

2: Changing the setting of the IRCF bits (OSCCON<6:4>) clears the WDT and postscaler counts.

3: When a CLRWDT instruction is executed the postscaler count will be cleared.

19.2.1 CONTROL REGISTER

Register 19-14 shows the WDTCON register. This is a readable and writable register, which contains a control bit that allows software to override the WDT enable configuration bit, only if the configuration bit has disabled the WDT.

FIGURE 19-1: WDT BLOCK DIAGRAM

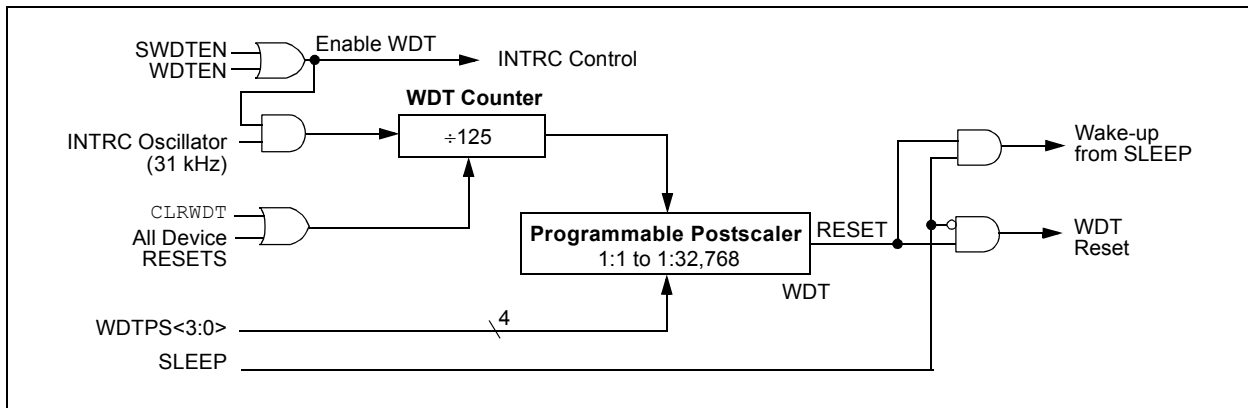

REGISTER 19-14: WDTCON REGISTER

U-0	U-0	U-0	U-0	U-0	U-0	U-0	R/W-0
—	—	—	—	—	—	—	SWDTEN
bit 7							bit 0

bit 7-1 **Unimplemented:** Read as '0'
 bit 0 **SWDTEN:** Software Controlled Watchdog Timer Enable bit
 1 = Watchdog Timer is on
 0 = Watchdog Timer is off

Note: This bit has no effect if the configuration bit WDTEN (CONFIG2H<0>) is enabled.

Legend:	
R = Readable bit	W = Writable bit
U = Unimplemented bit, read as '0'	- n = Value at POR

TABLE 19-2: SUMMARY OF WATCHDOG TIMER REGISTERS

Name	Bit 7	Bit 6	Bit 5	Bit 4	Bit 3	Bit 2	Bit 1	Bit 0
CONFIG2H	—	—	—	WDTPS3	WDTPS2	WDTPS2	WDTPS0	WDTEN
RCON	IPEN	—	—	RI	TO	PD	POR	BOR
WDTCON	—	—	—	—	—	—	—	SWDTEN

Legend: Shaded cells are not used by the Watchdog Timer.

19.3 Two-Speed Start-up

The Two-Speed Start-up feature helps to minimize the latency period from oscillator start-up to code execution, by allowing the microcontroller to use the INTRC oscillator as a clock source until the primary clock source is available. It is enabled by setting the IESO bit in Configuration Register 1H (CONFIG1H<7>).

Two-Speed Start-up is available only if the primary Oscillator mode is LP, XT, HS, or HSPLL (Crystal Based modes). Other sources do not require a OST start-up delay; for these, Two-Speed Start-up is disabled.

When enabled, RESETS and wake-ups from SLEEP mode cause the device to configure itself to run from the internal oscillator block as the clock source, following the time-out of the Power-up Timer after a POR RESET is enabled. This allows almost immediate code execution while the primary oscillator starts and the OST is running. Once the OST times out, the device automatically switches to PRI_RUN mode.

Because the OSCCON register is cleared on RESET events, the INTOSC (or postscaler) clock source is not initially available after a RESET event; the INTRC clock is used directly at its base frequency. To use a higher clock speed on wake-up, the INTOSC or postscaler clock sources can be selected to provide a higher clock speed by setting bits IFRC2:IFRC0 immediately after RESET. For wake-ups from SLEEP, the INTOSC or postscaler clock sources can be selected by setting IFRC2:IFRC0 prior to entering SLEEP mode.

In all other Power Managed modes, Two-Speed Start-up is not used. The device will be clocked by the currently selected clock source until the primary clock source becomes available. The setting of the IESO bit is ignored.

19.3.1 SPECIAL CONSIDERATIONS FOR USING TWO-SPEED START-UP

While using the INTRC oscillator in Two-Speed Start-up, the device still obeys the normal command sequences for entering Power Managed modes, including serial SLEEP instructions (refer to “Multiple SLEEP Commands” in Section 3.1.3). In practice, this means that user code can change the SCS1:SCS0 bit settings and issue SLEEP commands before the OST times out. This would allow an application to briefly wake-up, perform routine “housekeeping” tasks and return to SLEEP before the device starts to operate from the primary oscillator.

User code can also check if the primary clock source is currently providing the system clocking by checking the status of the OSTS bit (OSCCON<3>). If the bit is set, the primary oscillator is providing the system clock. Otherwise, the internal oscillator block is providing the clock during wake-up from RESET or SLEEP mode.

FIGURE 19-2: TIMING TRANSITION FOR TWO-SPEED START-UP (INTOSC TO HSPLL)

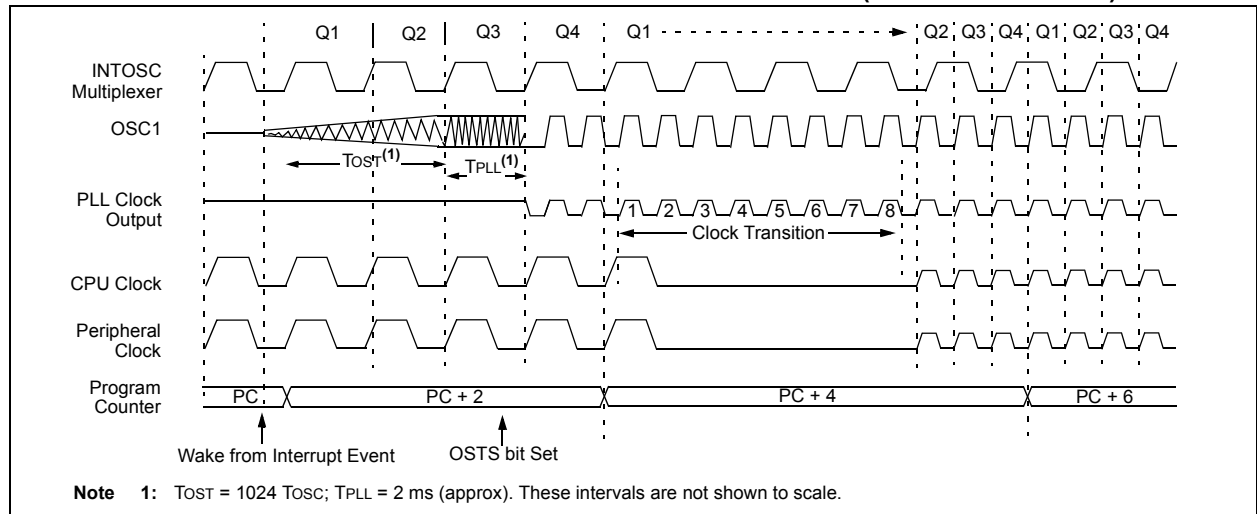

PIC18F1220/1320

19.4 Fail-Safe Clock Monitor

The Fail-Safe Clock Monitor (FSCM) allows the microcontroller to continue operation in the event of an external oscillator failure, by automatically switching the system clock to the internal oscillator block. The FSCM function is enabled by setting the Fail-Safe Clock Monitor Enable bit, FCMEN (CONFIG1H<6>).

When FSCM is enabled, the INTRC oscillator runs at all times to monitor clocks to peripherals and provide an instant backup clock in the event of a clock failure. Clock monitoring (shown in Figure 19-1) is accomplished by creating a sample clock signal, which is the INTRC output divided by 64. This allows ample time between FSCM sample clocks for a peripheral clock edge to occur. The peripheral system clock and the sample clock are presented as inputs to the Clock Monitor latch (CM). The CM is set on the falling edge of the system clock source, but cleared on the rising edge of the sample clock.

FIGURE 19-1: FSCM BLOCK DIAGRAM

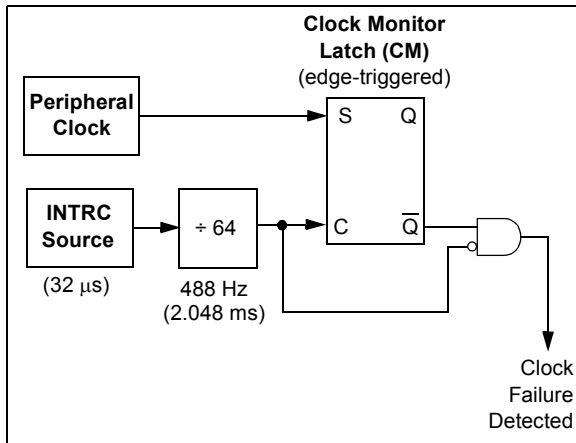

Clock failure is tested for on the falling edge of the sample clock. If a sample clock falling edge occurs while CM is still set, a clock failure has been detected (Figure 19-2). This causes the following:

- the FSCM generates an oscillator fail interrupt by setting bit OSCFIF (PIR2<7>);
- the system clock source is switched to the internal oscillator block (OSCCON is not updated to show the current clock source – this is the fail-safe condition); and
- the WDT is reset.

Since the postscaler frequency from the internal oscillator block may not be sufficiently stable, it may be desirable to select another clock configuration and enter an alternate Power Managed mode (see Sections 19.3.1 and 3.1.3 for more details). This can be done to attempt a partial recovery, or execute a controlled shutdown.

To use a higher clock speed on wake-up, the INTOSC or postscaler clock sources can be selected to provide a higher clock speed by setting bits IFRC2:IFRC0 immediately after RESET. For wake-ups from SLEEP, the INTOSC or postscaler clock sources can be selected by setting IFRC2:IFRC0 prior to entering SLEEP mode.

Adjustments to the internal oscillator block using the OSCTUNE register also affect the period of the FSCM by the same factor. This can usually be neglected, as the clock frequency being monitored is generally much higher than the sample clock frequency.

The FSCM will detect failures of the primary or secondary clock sources only. If the internal oscillator block fails, no failure would be detected, nor would any action be possible.

19.4.1 FSCM AND THE WATCHDOG TIMER

Both the FSCM and the WDT are clocked by the INTRC oscillator. Since the WDT operates with a separate divider and counter, disabling the WDT has no effect on the operation of the INTRC oscillator when the FSCM is enabled.

As already noted, the clock source is switched to the INTOSC clock when a clock failure is detected. Depending on the frequency selected by the IRCF2:IRCF0 bits, this may mean a substantial change in the speed of code execution. If the WDT is enabled with a small prescale value, a decrease in clock speed allows a WDT time-out to occur, and a subsequent device RESET. For this reason, fail-safe clock events also reset the WDT and postscaler, allowing it to start timing from when execution speed was changed and decreasing the likelihood of an erroneous time-out.

19.4.2 EXITING FAIL-SAFE OPERATION

The fail-safe condition is terminated by either a device RESET, or by entering a Power Managed mode. On RESET, the controller starts the primary clock source specified in Configuration Register 1H (with any required start-up delays that are required for the Oscillator mode, such as OST or PLL timer). The INTOSC multiplexer provides the system clock until the primary clock source becomes ready (similar to a Two-Speed Start-up). The clock system source is then switched to the primary clock (indicated by the OSTS bit in the OSCCON register becoming set). The Fail-Safe Clock Monitor then resumes monitoring the peripheral clock.

The primary clock source may never become ready during start-up. In this case, operation is clocked by the INTOSC multiplexer. The OSCCON register will remain in its RESET state until a Power Managed mode is entered.

Entering a Power Managed mode by loading the OSCCON register and executing a `SLEEP` instruction will clear the fail-safe condition. When the fail-safe condition is cleared, the clock monitor will resume monitoring the peripheral clock.

19.4.3 FSCM INTERRUPTS IN POWER MANAGED MODES

As previously mentioned, entering a Power Managed mode clears the fail-safe condition. By entering a Power Managed mode, the clock multiplexer selects the clock source selected by the OSCCON register. Fail-safe monitoring of the Power Managed clock source resumes in the Power Managed mode.

If an oscillator failure occurs during Power Managed operation, the subsequent events depend on whether or not the oscillator failure interrupt is enabled. If enabled (`OSCFIF = 1`), code execution will be clocked by the INTOSC multiplexer. An automatic transition back to the failed clock source will not occur.

If the interrupt is disabled, the device will not exit the Power Managed mode on oscillator failure. Instead, the device will continue to operate as before, but clocked by the INTOSC multiplexer. While in IDLE mode, subsequent interrupts will cause the CPU to begin executing instructions while being clocked by the INTOSC multiplexer. The device will not transition to a different clock source until the fail-safe condition is cleared.

FIGURE 19-2: FSCM TIMING DIAGRAM

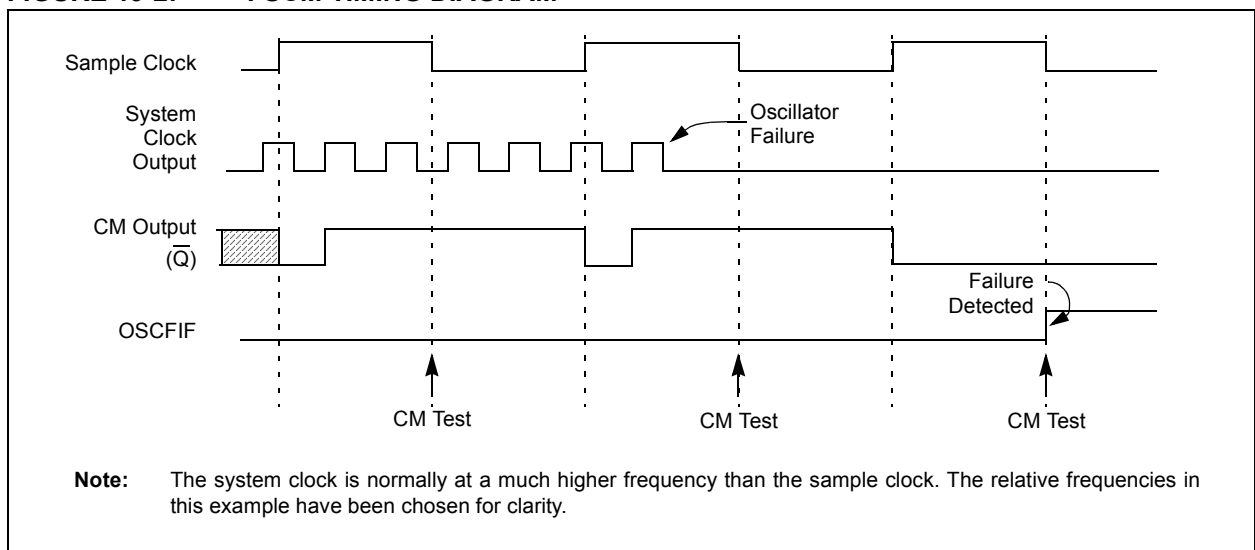

PIC18F1220/1320

19.4.4 POR OR WAKE FROM SLEEP

The FSCM is designed to detect oscillator failure at any point after the device has exited Power-on Reset (POR) or Low Power SLEEP mode. When the primary system clock is EC, RC or INTRC modes, monitoring can begin immediately following these events.

For Oscillator modes involving a crystal or resonator (HS, HSPLL, LP or XT), the situation is somewhat different. Since the oscillator may require a start-up time considerably longer than the FSCM sample clock time, a false clock failure may be detected. To prevent this, the internal oscillator block is automatically configured as the system clock, and functions until the primary clock is stable (the OST and PLL timers have timed out). This is identical to Two-Speed Start-up mode. Once the primary clock is stable, the INTRC returns to its role as the FSCM source

Note: The same logic that prevents false oscillator failure interrupts on POR or wake from SLEEP, will also prevent the detection of the oscillator's failure to start at all following these events. This can be avoided by monitoring the OSTS bit and using a timing routine to determine if the oscillator is taking too long to start. Even so, no oscillator failure interrupt will be flagged.

As noted in Section 19.3.1, it is also possible to select another clock configuration and enter an alternate Power Managed mode while waiting for the primary system clock to become stable. When the new Powered Managed mode is selected, the primary clock is disabled.

19.5 Program Verification and Code Protection

The overall structure of the code protection on the PIC18 FLASH devices differs significantly from other PICmicro® devices.

The user program memory is divided into three blocks. One of these is a boot block of 512 bytes. The remainder of the memory is divided into two blocks on binary boundaries.

Each of the three blocks has three protection bits associated with them. They are:

- Code Protect bit (CPn)
- Write Protect bit (WRTn)
- External Block Table Read bit (EBTRn)

Figure 19-3 shows the program memory organization for 4- and 8-Kbyte devices, and the specific code protection bit associated with each block. The actual locations of the bits are summarized in Table 19-3.

FIGURE 19-3: CODE PROTECTED PROGRAM MEMORY FOR PIC18F1220/1320

Block Code Protection Controlled By:	Address Range	MEMORY SIZE / DEVICE		Address Range	Block Code Protection Controlled By:
		4 Kbytes (PIC18F1220)	8 Kbytes (PIC18F1320)		
CPB, WRTB, EBTRB	000000h 0001FFh	Boot Block	Boot Block	000000h 0001FFh	CPB, WRTB, EBTRB
CP0, WRT0, EBTR0	000200h 0007FFh	Block 0	Block 0	000200h	CP0, WRT0, EBTR0
CP1, WRT1, EBTR1	000800h 000FFFh	Block 1		000FFFh	
(Unimplemented Memory Space)	001000h	Unimplemented Read 0's	Block 1	001000h	CP1, WRT1, EBTR1
	001FFFh 002000h		Unimplemented Read 0's	001FFFh 002000h	(Unimplemented Memory Space)
	1FFFFFFh			1FFFFFFh	

TABLE 19-3: SUMMARY OF CODE PROTECTION REGISTERS

File Name	Bit 7	Bit 6	Bit 5	Bit 4	Bit 3	Bit 2	Bit 1	Bit 0
300008h	CONFIG5L	—	—	—	—	—	CP1	CP0
300009h	CONFIG5H	CPD	CPB	—	—	—	—	—
30000Ah	CONFIG6L	—	—	—	—	—	WRT1	WRT0
30000Bh	CONFIG6H	WRTD	WRTB	WRTC	—	—	—	—
30000Ch	CONFIG7L	—	—	—	—	—	EBTR1	EBTR0
30000Dh	CONFIG7H	—	EBTRB	—	—	—	—	—

Legend: Shaded cells are unimplemented.

PIC18F1220/1320

19.5.1 PROGRAM MEMORY CODE PROTECTION

The program memory may be read to, or written from, any location using the Table Read and Table Write instructions. The device ID may be read with Table Reads. The configuration registers may be read and written with the Table Read and Table Write instructions.

In normal Execution mode, the CPn bits have no direct effect. CPn bits inhibit external reads and writes. A block of user memory may be protected from Table Writes if the WRTn configuration bit is '0'. The EBTRn bits control Table Reads. For a block of user memory with the EBTRn bit set to '0', a Table Read instruction that executes from within that block is allowed to read.

A Table Read instruction that executes from a location outside of that block is not allowed to read, and will result in reading '0's. Figures 19-4 through 19-6 illustrate Table Write and Table Read protection.

Note: Code protection bits may only be written to a '0' from a '1' state. It is not possible to write a '1' to a bit in the '0' state. Code protection bits are only set to '1' by a full chip erase or block erase function. The full chip erase and block erase functions can only be initiated via ICSP or an external programmer.

FIGURE 19-4: TABLE WRITE (WRTn) DISALLOWED PIC18F1320

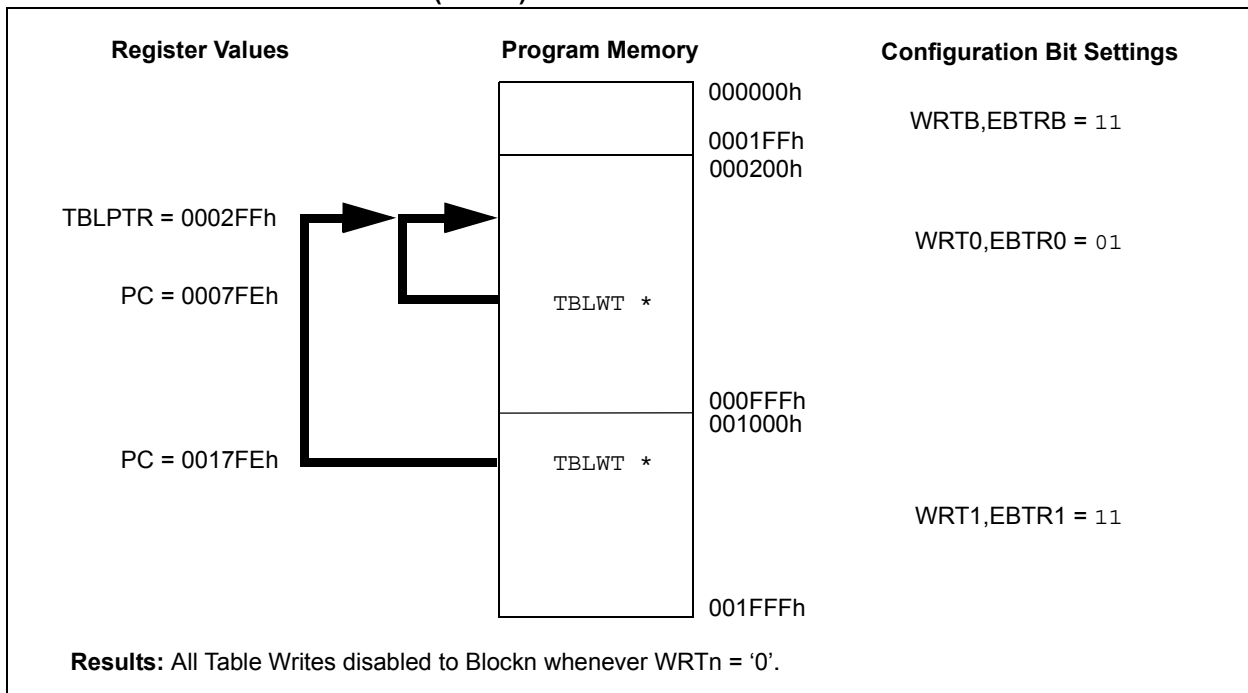

FIGURE 19-5: EXTERNAL BLOCK TABLE READ (EBTRn) DISALLOWED PIC18F1320

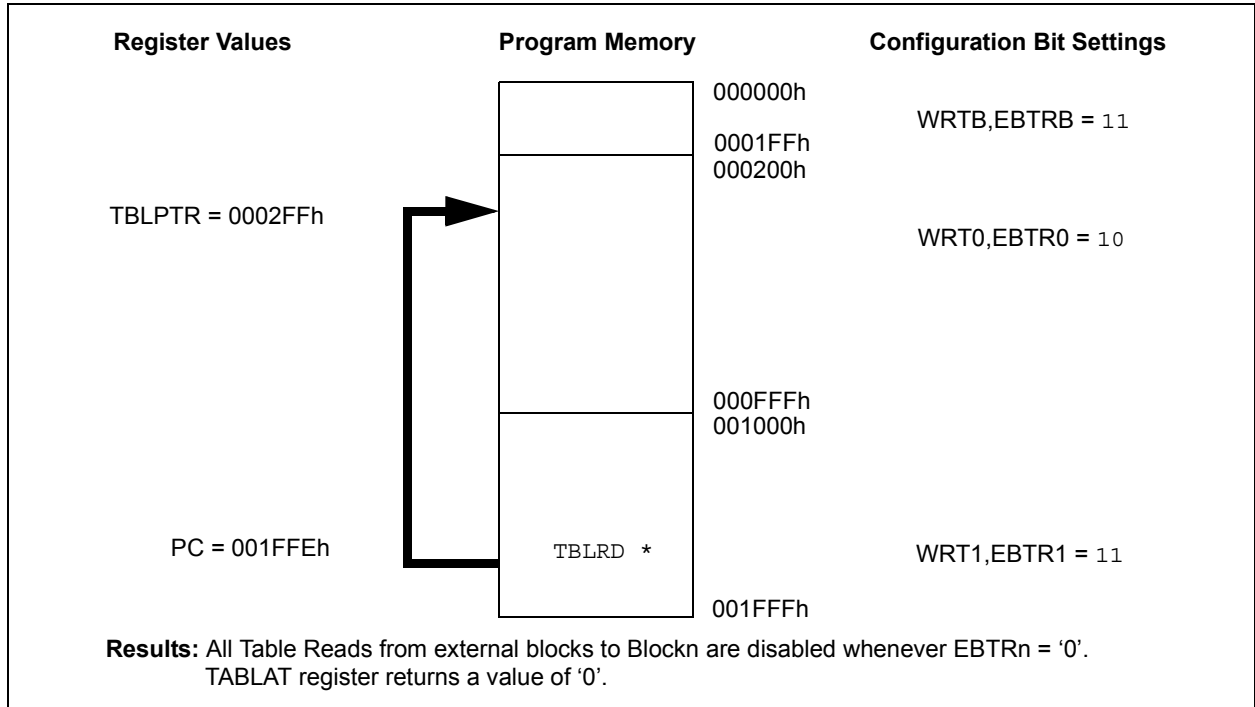
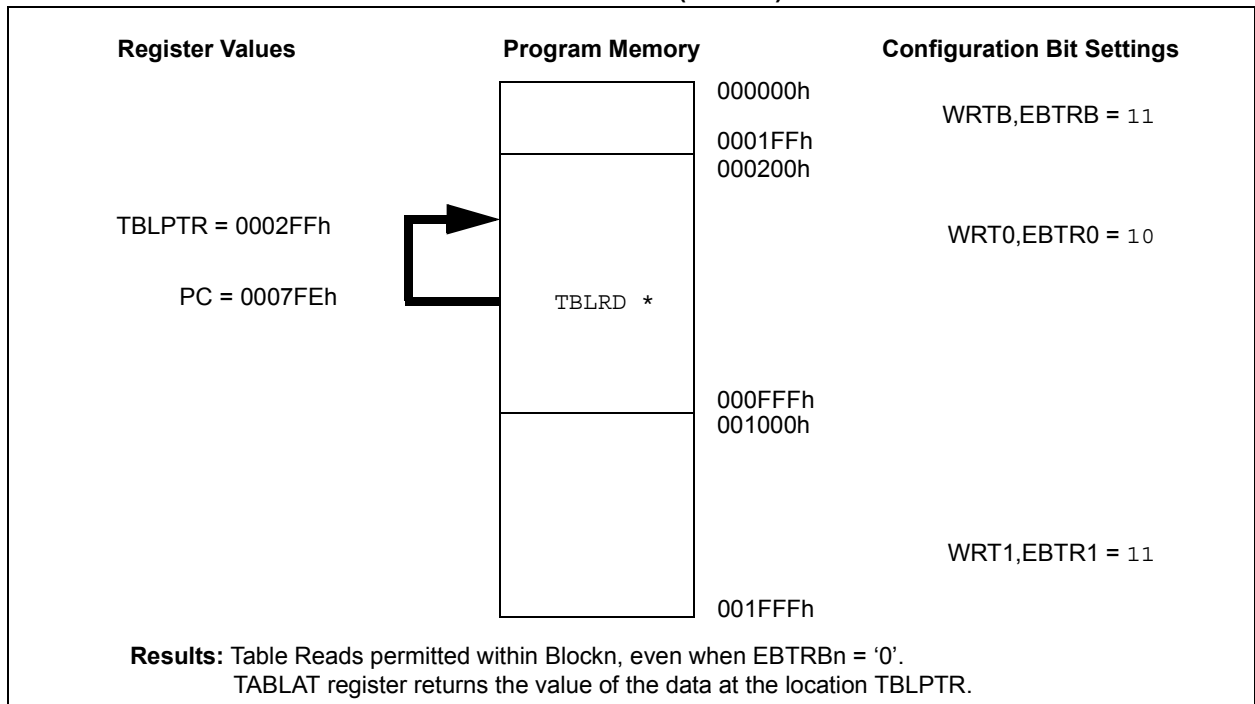

FIGURE 19-6: EXTERNAL BLOCK TABLE READ (EBTRn) ALLOWED PIC18F1320



PIC18F1220/1320

19.5.2 DATA EEPROM CODE PROTECTION

The entire data EEPROM is protected from external reads and writes by two bits: CPD and WRTD. CPD inhibits external reads and writes of Data EEPROM. WRTD inhibits external writes to Data EEPROM. The CPU can continue to read and write Data EEPROM, regardless of the protection bit settings.

19.5.3 CONFIGURATION REGISTER PROTECTION

The configuration registers can be write protected. The WRTC bit controls protection of the configuration registers. In normal Execution mode, the WRTC bit is readable only. WRTC can only be written via ICSP or an external programmer.

19.6 ID Locations

Eight memory locations (200000h - 200007h) are designated as ID locations, where the user can store checksum, or other code identification numbers. These locations are both readable and writable during normal execution through the TBLRD and TBLWT instructions, or during program/verify. The ID locations can be read when the device is code protected.

19.7 In-Circuit Serial Programming

PIC18F1220/1320 microcontrollers can be serially programmed while in the end application circuit. This is simply done with two lines for clock and data and three other lines for power, ground and the programming voltage. This allows customers to manufacture boards with unprogrammed devices, and then program the microcontroller just before shipping the product. This also allows the most recent firmware or a custom firmware to be programmed.

19.8 In-Circuit Debugger

When the DEBUG bit in configuration register CONFIG4L is programmed to a '0', the In-Circuit Debugger functionality is enabled. This function allows simple debugging functions when used with MPLAB® IDE. When the microcontroller has this feature enabled, some resources are not available for general use. Table 19-4 shows which resources are required by the background debugger.

TABLE 19-4: DEBUGGER RESOURCES

I/O pins:	RB6, RB7
Stack:	2 levels
Program Memory:	512 bytes
Data Memory:	10 bytes

To use the In-Circuit Debugger function of the microcontroller, the design must implement In-Circuit Serial Programming connections to MCLR/VPP, VDD, VSS, RB7 and RB6. This will interface to the In-Circuit Debugger module available from Microchip, or one of the third party development tool companies.

19.9 Low Voltage ICSP Programming

The LVP bit in configuration register CONFIG4L enables Low Voltage Programming (LVP). When LVP is enabled, the microcontroller can be programmed without requiring high voltage being applied to the MCLR/VPP pin, but the RB5/PGM pin is then dedicated to controlling Program mode entry and is not available as a general purpose I/O pin.

LVP is enabled in erased devices.

While programming using LVP, VDD is applied to the MCLR/VPP pin as in normal Execution mode. To enter Programming mode, VDD is applied to the PGM pin.

- Note 1:** High voltage programming is always available, regardless of the state of the LVP bit or the PGM pin, by applying VIH to the MCLR pin.
- 2:** When Low Voltage Programming is enabled, the RB5 pin can no longer be used as a general purpose I/O pin.
- 3:** When LVP is enabled, externally pull the PGM pin to VSS to allow normal program execution.

If Low Voltage Programming mode will not be used, the LVP bit can be cleared and RB5/PGM becomes available as the digital I/O pin RB5. The LVP bit may be set or cleared only when using standard high voltage programming (VIH applied to the MCLR/VPP pin). Once LVP has been disabled, only the standard high voltage programming is available and must be used to program the device.

Memory that is not code protected can be erased, using either a block erase, or erased row by row, then written at any specified VDD. If code protected memory is to be erased, a block erase is required. If a block erase is to be performed when using low voltage programming, the device must be supplied with VDD of 4.5V to 5.5V.

20.0 INSTRUCTION SET SUMMARY

The PIC18 instruction set adds many enhancements to the previous PICmicro instruction sets, while maintaining an easy migration from these PICmicro instruction sets.

Most instructions are a single program memory word (16 bits), but there are three instructions that require two program memory locations.

Each single word instruction is a 16-bit word divided into an OPCODE, which specifies the instruction type and one or more operands, which further specify the operation of the instruction.

The instruction set is highly orthogonal and is grouped into four basic categories:

- **Byte-oriented** operations
- **Bit-oriented** operations
- **Literal** operations
- **Control** operations

The PIC18 instruction set summary in Table 20-2 lists **byte-oriented**, **bit-oriented**, **literal** and **control** operations. Table 20-1 shows the opcode field descriptions.

Most **byte-oriented** instructions have three operands:

1. The file register (specified by 'f')
2. The destination of the result (specified by 'd')
3. The accessed memory (specified by 'a')

The file register designator 'f' specifies which file register is to be used by the instruction.

The destination designator 'd' specifies where the result of the operation is to be placed. If 'd' is zero, the result is placed in the WREG register. If 'd' is one, the result is placed in the file register specified in the instruction.

All **bit-oriented** instructions have three operands:

1. The file register (specified by 'f')
2. The bit in the file register (specified by 'b')
3. The accessed memory (specified by 'a')

The bit field designator 'b' selects the number of the bit affected by the operation, while the file register designator 'f' represents the number of the file in which the bit is located.

The **literal** instructions may use some of the following operands:

- A literal value to be loaded into a file register (specified by 'k')
- The desired FSR register to load the literal value into (specified by 'f')
- No operand required (specified by '—')

The **control** instructions may use some of the following operands:

- A program memory address (specified by 'n')
- The mode of the CALL or RETURN instructions (specified by 's')
- The mode of the Table Read and Table Write instructions (specified by 'm')
- No operand required (specified by '—')

All instructions are a single word, except for three double-word instructions. These three instructions were made double-word instructions, so that all the required information is available in these 32 bits. In the second word, the 4 MSBs are 1's. If this second word is executed as an instruction (by itself), it will execute as a NOP.

All single word instructions are executed in a single instruction cycle, unless a conditional test is true, or the program counter is changed as a result of the instruction. In these cases, the execution takes two instruction cycles, with the additional instruction cycle(s) executed as a NOP.

The double-word instructions execute in two instruction cycles.

One instruction cycle consists of four oscillator periods. Thus, for an oscillator frequency of 4 MHz, the normal instruction execution time is 1 μ s. If a conditional test is true, or the program counter is changed as a result of an instruction, the instruction execution time is 2 μ s. Two-word branch instructions (if true) would take 3 μ s.

Figure 20-1 shows the general formats that the instructions can have.

All examples use the format '*nnh*' to represent a hexadecimal number, where '*h*' signifies a hexadecimal digit.

The Instruction Set Summary, shown in Table 20-2, lists the instructions recognized by the Microchip Assembler (MPASM™). Section 20.2 provides a description of each instruction.

20.1 READ-MODIFY-WRITE OPERATIONS

Any instruction that specifies a file register as part of the instruction performs a Read-Modify-Write (R-M-W) operation. The register is read, the data is modified, and the result is stored according to either the instruction or the destination designator 'd'. A read operation is performed on a register even if the instruction writes to that register.

For example, a "BCF PORTB,1" instruction will read PORTB, clear bit 1 of the data, then write the result back to PORTB. The read operation would have the unintended result that any condition that sets the RBIF flag would be cleared. The R-M-W operation may also copy the level of an input pin to its corresponding output latch.

PIC18F1220/1320

TABLE 20-1: OPCODE FIELD DESCRIPTIONS

Field	Description
a	RAM access bit a = 0: RAM location in Access RAM (BSR register is ignored) a = 1: RAM bank is specified by BSR register
bbb	Bit address within an 8-bit file register (0 to 7)
BSR	Bank Select Register. Used to select the current RAM bank.
d	Destination select bit; d = 0: store result in WREG, d = 1: store result in file register f.
dest	Destination either the WREG register or the specified register file location
f	8-bit Register file address (0x00 to 0xFF)
fs	12-bit Register file address (0x000 to 0xFFF). This is the source address.
fd	12-bit Register file address (0x000 to 0xFFF). This is the destination address.
k	Literal field, constant data or label (may be either an 8-bit, 12-bit or a 20-bit value)
label	Label name
mm	The mode of the TBLPTR register for the Table Read and Table Write instructions. Only used with Table Read and Table Write instructions:
*	No Change to register (such as TBLPTR with Table reads and writes)
*+	Post-Increment register (such as TBLPTR with Table reads and writes)
*-	Post-Decrement register (such as TBLPTR with Table reads and writes)
+*	Pre-Increment register (such as TBLPTR with Table reads and writes)
n	The relative address (2's complement number) for relative branch instructions, or the direct address for Call/Branch and Return instructions
PRODH	Product of Multiply high byte
PRODL	Product of Multiply low byte
s	Fast Call/Return mode select bit s = 0: do not update into/from shadow registers s = 1: certain registers loaded into/from shadow registers (Fast mode)
u	Unused or Unchanged
WREG	Working register (accumulator)
x	Don't care (0 or 1) The assembler will generate code with x = 0. It is the recommended form of use for compatibility with all Microchip software tools.
TBLPTR	21-bit Table Pointer (points to a Program Memory location)
TABLAT	8-bit Table Latch
TOS	Top-of-Stack
PC	Program Counter
PCL	Program Counter Low Byte
PCH	Program Counter High Byte
PCLATH	Program Counter High Byte Latch
PCLATU	Program Counter Upper Byte Latch
GIE	Global Interrupt Enable bit
WDT	Watchdog Timer
\overline{TO}	Time-out bit
\overline{PD}	Power-down bit
C, DC, Z, OV, N	ALU status bits Carry, Digit Carry, Zero, Overflow, Negative
[]	Optional
()	Contents
→	Assigned to
< >	Register bit field
∈	In the set of
<i>italics</i>	User defined term (font is Courier)

FIGURE 20-1: GENERAL FORMAT FOR INSTRUCTIONS

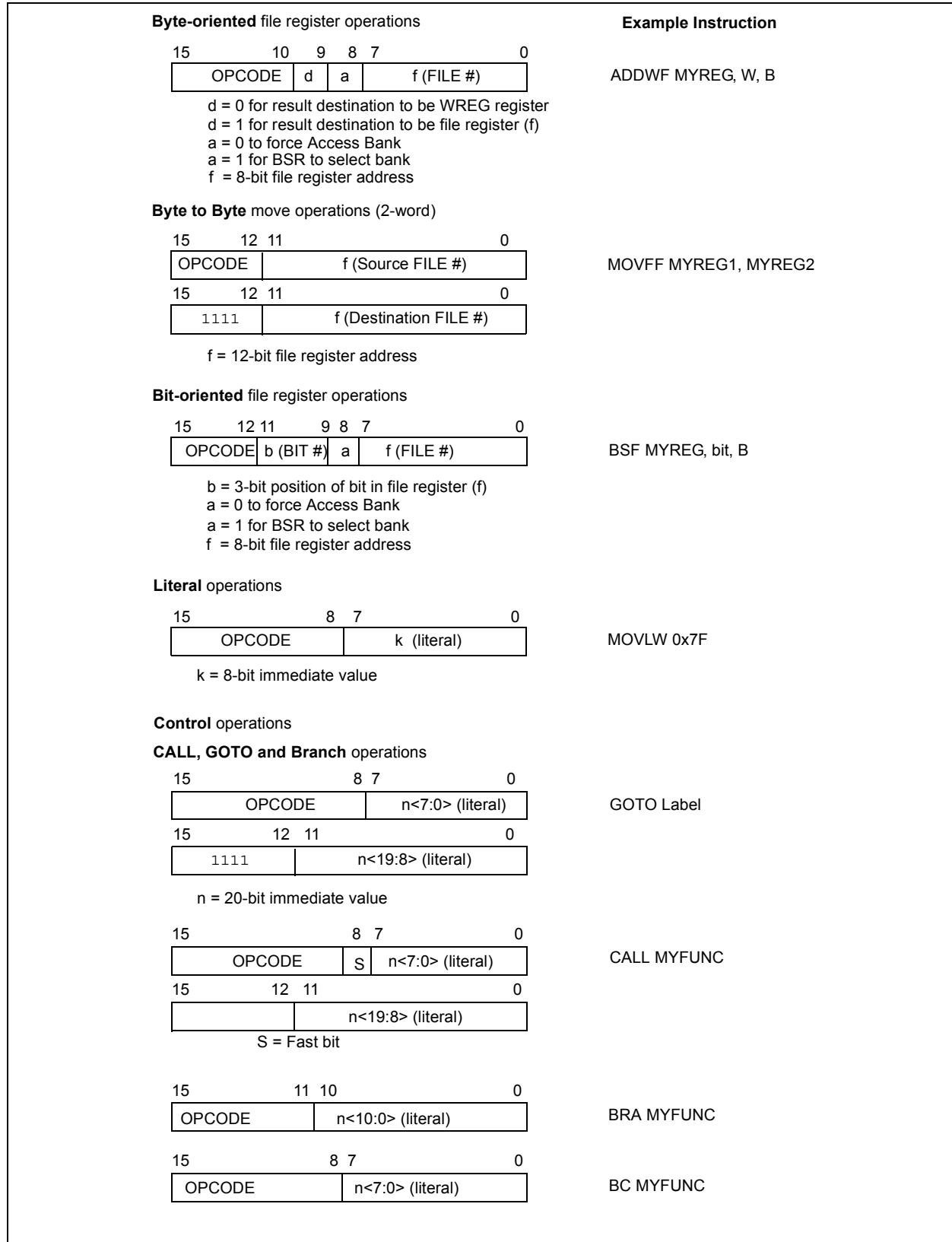

PIC18F1220/1320

TABLE 20-2: PIC18FXXX INSTRUCTION SET

Mnemonic, Operands	Description	Cycles	16-Bit Instruction Word				Status Affected	Notes	
			MSb	LSb					
BYTE-ORIENTED FILE REGISTER OPERATIONS									
ADDWF	f, d, a	Add WREG and f	1	0010	01da	ffff	ffff	C, DC, Z, OV, N	1, 2
ADDWFC	f, d, a	Add WREG and Carry bit to f	1	0010	00da	ffff	ffff	C, DC, Z, OV, N	1, 2
ANDWF	f, d, a	AND WREG with f	1	0001	01da	ffff	ffff	Z, N	1, 2
CLRF	f, a	Clear f	1	0110	101a	ffff	ffff	Z	2
COMF	f, d, a	Complement f	1	0001	11da	ffff	ffff	Z, N	1, 2
CPFSEQ	f, a	Compare f with WREG, skip =	1 (2 or 3)	0110	001a	ffff	ffff	None	4
CPFSGT	f, a	Compare f with WREG, skip >	1 (2 or 3)	0110	010a	ffff	ffff	None	4
CPFSLT	f, a	Compare f with WREG, skip <	1 (2 or 3)	0110	000a	ffff	ffff	None	1, 2
DECF	f, d, a	Decrement f	1	0000	01da	ffff	ffff	C, DC, Z, OV, N	1, 2, 3, 4
DECFSZ	f, d, a	Decrement f, Skip if 0	1 (2 or 3)	0010	11da	ffff	ffff	None	1, 2, 3, 4
DCFSNZ	f, d, a	Decrement f, Skip if Not 0	1 (2 or 3)	0100	11da	ffff	ffff	None	1, 2
INCF	f, d, a	Increment f	1	0010	10da	ffff	ffff	C, DC, Z, OV, N	1, 2, 3, 4
INCFSZ	f, d, a	Increment f, Skip if 0	1 (2 or 3)	0011	11da	ffff	ffff	None	4
INFSNZ	f, d, a	Increment f, Skip if Not 0	1 (2 or 3)	0100	10da	ffff	ffff	None	1, 2
IORWF	f, d, a	Inclusive OR WREG with f	1	0001	00da	ffff	ffff	Z, N	1, 2
MOVF	f, d, a	Move f	1	0101	00da	ffff	ffff	Z, N	1
MOVFF	f _s , f _d	Move f _s (source) to 1st word f _d (destination)2nd word	2	1100	ffff	ffff	ffff	None	
MOVWF	f, a	Move WREG to f	1	0110	111a	ffff	ffff	None	
MULWF	f, a	Multiply WREG with f	1	0000	001a	ffff	ffff	None	
NEGF	f, a	Negate f	1	0110	110a	ffff	ffff	C, DC, Z, OV, N	1, 2
RLCF	f, d, a	Rotate Left f through Carry	1	0011	01da	ffff	ffff	C, Z, N	
RLNCF	f, d, a	Rotate Left f (No Carry)	1	0100	01da	ffff	ffff	Z, N	1, 2
RRCF	f, d, a	Rotate Right f through Carry	1	0011	00da	ffff	ffff	C, Z, N	
RRNCF	f, d, a	Rotate Right f (No Carry)	1	0100	00da	ffff	ffff	Z, N	
SETF	f, a	Set f	1	0110	100a	ffff	ffff	None	
SUBFWB	f, d, a	Subtract f from WREG with borrow	1	0101	01da	ffff	ffff	C, DC, Z, OV, N	1, 2
SUBWF	f, d, a	Subtract WREG from f	1	0101	11da	ffff	ffff	C, DC, Z, OV, N	
SUBWFB	f, d, a	Subtract WREG from f with borrow	1	0101	10da	ffff	ffff	C, DC, Z, OV, N	1, 2
SWAPF	f, d, a	Swap nibbles in f	1	0011	10da	ffff	ffff	None	4
TSTFSZ	f, a	Test f, skip if 0	1 (2 or 3)	0110	011a	ffff	ffff	None	1, 2
XORWF	f, d, a	Exclusive OR WREG with f	1	0001	10da	ffff	ffff	Z, N	
BIT-ORIENTED FILE REGISTER OPERATIONS									
BCF	f, b, a	Bit Clear f	1	1001	bbba	ffff	ffff	None	1, 2
BSF	f, b, a	Bit Set f	1	1000	bbba	ffff	ffff	None	1, 2
BTFSC	f, b, a	Bit Test f, Skip if Clear	1 (2 or 3)	1011	bbba	ffff	ffff	None	3, 4
BTFSS	f, b, a	Bit Test f, Skip if Set	1 (2 or 3)	1010	bbba	ffff	ffff	None	3, 4
BTG	f, d, a	Bit Toggle f	1	0111	bbba	ffff	ffff	None	1, 2

Note 1: When a PORT register is modified as a function of itself (e.g., MOVF PORTB, 1, 0), the value used will be that value present on the pins themselves. For example, if the data latch is '1' for a pin configured as input and is driven low by an external device, the data will be written back with a '0'.

- If this instruction is executed on the TMR0 register (and where applicable, d = 1), the prescaler will be cleared if assigned.
- If Program Counter (PC) is modified or a conditional test is true, the instruction requires two cycles. The second cycle is executed as a NOP.
- Some instructions are 2-word instructions. The second word of these instructions will be executed as a NOP, unless the first word of the instruction retrieves the information embedded in these 16-bits. This ensures that all program memory locations have a valid instruction.
- If the Table Write starts the write cycle to internal memory, the write will continue until terminated.

TABLE 20-2: PIC18FXXX INSTRUCTION SET (CONTINUED)

Mnemonic, Operands	Description	Cycles	16-Bit Instruction Word				Status Affected	Notes	
			MSb	LSb					
CONTROL OPERATIONS									
BC	n	Branch if Carry	1 (2)	1110	0010	nnnn	nnnn	None	
BN	n	Branch if Negative	1 (2)	1110	0110	nnnn	nnnn	None	
BNC	n	Branch if Not Carry	1 (2)	1110	0011	nnnn	nnnn	None	
BNN	n	Branch if Not Negative	1 (2)	1110	0111	nnnn	nnnn	None	
BNOV	n	Branch if Not Overflow	1 (2)	1110	0101	nnnn	nnnn	None	
BNZ	n	Branch if Not Zero	2	1110	0001	nnnn	nnnn	None	
BOV	n	Branch if Overflow	1 (2)	1110	0100	nnnn	nnnn	None	
BRA	n	Branch Unconditionally	1 (2)	1101	0nnn	nnnn	nnnn	None	
BZ	n	Branch if Zero	1 (2)	1110	0000	nnnn	nnnn	None	
CALL	n, s	Call subroutine	2	1110	110s	kkkk	kkkk	None	
		1st word							
		2nd word		1111	kkkk	kkkk	kkkk		
CLRWDT	—	Clear Watchdog Timer	1	0000	0000	0000	0100	TO, PD	
DAW	—	Decimal Adjust WREG	1	0000	0000	0000	0111	C	
GOTO	n	Go to address	2	1110	1111	kkkk	kkkk	None	
		1st word							
		2nd word		1111	kkkk	kkkk	kkkk		
NOP	—	No Operation	1	0000	0000	0000	0000	None	
NOP	—	No Operation	1	1111	xxxx	xxxx	xxxx	None	4
POP	—	Pop top of return stack (TOS)	1	0000	0000	0000	0110	None	
PUSH	—	Push top of return stack (TOS)	1	0000	0000	0000	0101	None	
RCALL	n	Relative Call	2	1101	1nnn	nnnn	nnnn	None	
RESET		Software device RESET	1	0000	0000	1111	1111	All	
RETFIE	s	Return from interrupt enable	2	0000	0000	0001	000s	GIE/GIEH, PEIE/GIEL	
RETLW	k	Return with literal in WREG	2	0000	1100	kkkk	kkkk	None	
RETURN	s	Return from Subroutine	2	0000	0000	0001	001s	None	
SLEEP	—	Go into Standby mode	1	0000	0000	0000	0011	TO, PD	

- Note 1:** When a PORT register is modified as a function of itself (e.g., `MOVWF PORTB, 1, 0`), the value used will be that value present on the pins themselves. For example, if the data latch is '1' for a pin configured as input and is driven low by an external device, the data will be written back with a '0'.
- 2:** If this instruction is executed on the TMR0 register (and where applicable, $d = 1$), the prescaler will be cleared if assigned.
- 3:** If Program Counter (PC) is modified or a conditional test is true, the instruction requires two cycles. The second cycle is executed as a `NOPE`.
- 4:** Some instructions are 2-word instructions. The second word of these instructions will be executed as a `NOPE`, unless the first word of the instruction retrieves the information embedded in these 16-bits. This ensures that all program memory locations have a valid instruction.
- 5:** If the Table Write starts the write cycle to internal memory, the write will continue until terminated.

PIC18F1220/1320

TABLE 20-2: PIC18FXXX INSTRUCTION SET (CONTINUED)

Mnemonic, Operands	Description	Cycles	16-Bit Instruction Word				Status Affected	Notes	
			MSb		LSb				
LITERAL OPERATIONS									
ADDLW	k	Add literal and WREG	1	0000	1111	kkkk	kkkk	C, DC, Z, OV, N	
ANDLW	k	AND literal with WREG	1	0000	1011	kkkk	kkkk	Z, N	
IORLW	k	Inclusive OR literal with WREG	1	0000	1001	kkkk	kkkk	Z, N	
LFSR	f, k	Move literal (12-bit)2nd word to FSRx 1st word	2	1110	1110	00ff	kkkk	None	
MOVLB	k	Move literal to BSR<3:0>	1	0000	0001	0000	kkkk	None	
MOVLW	k	Move literal to WREG	1	0000	1110	kkkk	kkkk	None	
MULLW	k	Multiply literal with WREG	1	0000	1101	kkkk	kkkk	None	
RETLW	k	Return with literal in WREG	2	0000	1100	kkkk	kkkk	None	
SUBLW	k	Subtract WREG from literal	1	0000	1000	kkkk	kkkk	C, DC, Z, OV, N	
XORLW	k	Exclusive OR literal with WREG	1	0000	1010	kkkk	kkkk	Z, N	
DATA MEMORY ↔ PROGRAM MEMORY OPERATIONS									
TBLRD*		Table Read	2	0000	0000	0000	1000	None	
TBLRD*+		Table Read with post-increment		0000	0000	0000	1001	None	
TBLRD*-		Table Read with post-decrement		0000	0000	0000	1010	None	
TBLRD+*		Table Read with pre-increment		0000	0000	0000	1011	None	
TBLWT*		Table Write	2 (5)	0000	0000	0000	1100	None	
TBLWT*+		Table Write with post-increment		0000	0000	0000	1101	None	
TBLWT*-		Table Write with post-decrement		0000	0000	0000	1110	None	
TBLWT+*		Table Write with pre-increment		0000	0000	0000	1111	None	

- Note 1:** When a PORT register is modified as a function of itself (e.g., `MOVF PORTB, 1, 0`), the value used will be that value present on the pins themselves. For example, if the data latch is '1' for a pin configured as input and is driven low by an external device, the data will be written back with a '0'.
- 2:** If this instruction is executed on the TMR0 register (and where applicable, $d = 1$), the prescaler will be cleared if assigned.
- 3:** If Program Counter (PC) is modified or a conditional test is true, the instruction requires two cycles. The second cycle is executed as a `NOOP`.
- 4:** Some instructions are 2-word instructions. The second word of these instructions will be executed as a `NOOP`, unless the first word of the instruction retrieves the information embedded in these 16-bits. This ensures that all program memory locations have a valid instruction.
- 5:** If the Table Write starts the write cycle to internal memory, the write will continue until terminated.

20.2 Instruction Set

ADDLW	ADD literal to W								
Syntax:	[<i>label</i>] ADDLW k								
Operands:	$0 \leq k \leq 255$								
Operation:	$(W) + k \rightarrow W$								
Status Affected:	N, OV, C, DC, Z								
Encoding:	<table border="1"> <tr> <td>0000</td> <td>1111</td> <td>kkkk</td> <td>kkkk</td> </tr> </table>	0000	1111	kkkk	kkkk				
0000	1111	kkkk	kkkk						
Description:	The contents of W are added to the 8-bit literal 'k' and the result is placed in W.								
Words:	1								
Cycles:	1								
Q Cycle Activity:	<table border="1"> <tr> <th>Q1</th> <th>Q2</th> <th>Q3</th> <th>Q4</th> </tr> <tr> <td>Decode</td> <td>Read literal 'k'</td> <td>Process Data</td> <td>Write to W</td> </tr> </table>	Q1	Q2	Q3	Q4	Decode	Read literal 'k'	Process Data	Write to W
Q1	Q2	Q3	Q4						
Decode	Read literal 'k'	Process Data	Write to W						

Example: ADDLW 0x15

Before Instruction

W = 0x10

After Instruction

W = 0x25

ADDWF	ADD W to f								
Syntax:	[<i>label</i>] ADDWF f [,d [,a]]								
Operands:	$0 \leq f \leq 255$ $d \in [0,1]$ $a \in [0,1]$								
Operation:	$(W) + (f) \rightarrow \text{dest}$								
Status Affected:	N, OV, C, DC, Z								
Encoding:	<table border="1"> <tr> <td>0010</td> <td>01da</td> <td>ffff</td> <td>ffff</td> </tr> </table>	0010	01da	ffff	ffff				
0010	01da	ffff	ffff						
Description:	Add W to register 'f'. If 'd' is 0, the result is stored in W. If 'd' is 1, the result is stored back in register 'f' (default). If 'a' is 0, the Access Bank will be selected. If 'a' is 1, the BSR is used.								
Words:	1								
Cycles:	1								
Q Cycle Activity:	<table border="1"> <tr> <th>Q1</th> <th>Q2</th> <th>Q3</th> <th>Q4</th> </tr> <tr> <td>Decode</td> <td>Read register 'f'</td> <td>Process Data</td> <td>Write to destination</td> </tr> </table>	Q1	Q2	Q3	Q4	Decode	Read register 'f'	Process Data	Write to destination
Q1	Q2	Q3	Q4						
Decode	Read register 'f'	Process Data	Write to destination						

Example: ADDWF REG, W

Before Instruction

W = 0x17

REG = 0xC2

After Instruction

W = 0xD9

REG = 0xC2

PIC18F1220/1320

ADDWFC **ADD W and Carry bit to f**

Syntax: [*label*] ADDWFC f [,d [,a]]

Operands: $0 \leq f \leq 255$
 $d \in [0,1]$
 $a \in [0,1]$

Operation: (W) + (f) + (C) → dest

Status Affected: N,OV, C, DC, Z

Encoding:

0010	00da	ffff	ffff
------	------	------	------

Description: Add W, the Carry Flag and data memory location 'f'. If 'd' is 0, the result is placed in W. If 'd' is 1, the result is placed in data memory location 'f'. If 'a' is 0, the Access Bank will be selected. If 'a' is 1, the BSR will not be overridden.

Words: 1

Cycles: 1

Q Cycle Activity:

Q1	Q2	Q3	Q4
Decode	Read register 'f'	Process Data	Write to destination

Example: ADDWFC REG, W

Before Instruction

Carry bit = 1
REG = 0x02
W = 0x4D

After Instruction

Carry bit = 0
REG = 0x02
W = 0x50

ANDLW **AND literal with W**

Syntax: [*label*] ANDLW k

Operands: $0 \leq k \leq 255$

Operation: (W) .AND. k → W

Status Affected: N,Z

Encoding:

0000	1011	kkkk	kkkk
------	------	------	------

Description: The contents of W are ANDed with the 8-bit literal 'k'. The result is placed in W.

Words: 1

Cycles: 1

Q Cycle Activity:

Q1	Q2	Q3	Q4
Decode	Read literal 'k'	Process Data	Write to W

Example: ANDLW 0x5F

Before Instruction

W = 0xA3

After Instruction

W = 0x03

ANDWF AND W with f

Syntax: [*label*] ANDWF f [,d [,a]]

Operands: $0 \leq f \leq 255$
 $d \in [0,1]$
 $a \in [0,1]$

Operation: (W) .AND. (f) → dest

Status Affected: N,Z

Encoding:

0001	01da	ffff	ffff
------	------	------	------

Description: The contents of W are AND'ed with register 'f'. If 'd' is 0, the result is stored in W. If 'd' is 1, the result is stored back in register 'f' (default). If 'a' is 0, the Access Bank will be selected. If 'a' is 1, the BSR will not be overridden (default).

Words: 1

Cycles: 1

Q Cycle Activity:

Q1	Q2	Q3	Q4
Decode	Read register 'f'	Process Data	Write to destination

Example: ANDWF REG, W

Before Instruction

W = 0x17

REG = 0xC2

After Instruction

W = 0x02

REG = 0xC2

BC Branch if Carry

Syntax: [*label*] BC n

Operands: $-128 \leq n \leq 127$

Operation: if carry bit is '1'
 (PC) + 2 + 2n → PC

Status Affected: None

Encoding:

1110	0010	nnnn	nnnn
------	------	------	------

Description: If the Carry bit is '1', then the program will branch. The 2's complement number '2n' is added to the PC. Since the PC will have incremented to fetch the next instruction, the new address will be PC+2+2n. This instruction is then a two-cycle instruction.

Words: 1

Cycles: 1(2)

Q Cycle Activity:

If Jump:

Q1	Q2	Q3	Q4
Decode	Read literal 'n'	Process Data	Write to PC
No operation	No operation	No operation	No operation

If No Jump:

Q1	Q2	Q3	Q4
Decode	Read literal 'n'	Process Data	No operation

Example: HERE BC JUMP

Before Instruction

PC = address (HERE)

After Instruction

If Carry = 1;

PC = address (JUMP)

If Carry = 0;

PC = address (HERE+2)

PIC18F1220/1320

BCF Bit Clear f

Syntax: [*label*] BCF f,b[*a*]

Operands: $0 \leq f \leq 255$
 $0 \leq b \leq 7$
 $a \in [0,1]$

Operation: $0 \rightarrow f < b >$

Status Affected: None

Encoding:

1001	bbba	ffff	ffff
------	------	------	------

Description: Bit 'b' in register 'f' is cleared. If 'a' is 0, the Access Bank will be selected, overriding the BSR value. If 'a' = 1, then the bank will be selected as per the BSR value (default).

Words: 1

Cycles: 1

Q Cycle Activity:

Q1	Q2	Q3	Q4
Decode	Read register 'f'	Process Data	Write register 'f'

Example: BCF FLAG_REG, 7

Before Instruction
 FLAG_REG = 0xC7

After Instruction
 FLAG_REG = 0x47

BN Branch if Negative

Syntax: [*label*] BN n

Operands: $-128 \leq n \leq 127$

Operation: if negative bit is '1'
 $(PC) + 2 + 2n \rightarrow PC$

Status Affected: None

Encoding:

1110	0110	nnnn	nnnn
------	------	------	------

Description: If the Negative bit is '1', then the program will branch. The 2's complement number '2n' is added to the PC. Since the PC will have incremented to fetch the next instruction, the new address will be $PC+2+2n$. This instruction is then a two-cycle instruction.

Words: 1

Cycles: 1(2)

Q Cycle Activity:

If Jump:

Q1	Q2	Q3	Q4
Decode	Read literal 'n'	Process Data	Write to PC
No operation	No operation	No operation	No operation

If No Jump:

Q1	Q2	Q3	Q4
Decode	Read literal 'n'	Process Data	No operation

Example: HERE BN Jump

Before Instruction
 PC = address (HERE)

After Instruction
 If Negative = 1;
 PC = address (Jump)
 If Negative = 0;
 PC = address (HERE+2)

BNC Branch if Not Carry

Syntax: [*label*] BNC n

Operands: $-128 \leq n \leq 127$

Operation: if carry bit is '0'
 $(PC) + 2 + 2n \rightarrow PC$

Status Affected: None

Encoding:

1110	0011	nnnn	nnnn
------	------	------	------

Description: If the Carry bit is '0', then the program will branch. The 2's complement number '2n' is added to the PC. Since the PC will have incremented to fetch the next instruction, the new address will be $PC+2+2n$. This instruction is then a two-cycle instruction.

Words: 1

Cycles: 1(2)

Q Cycle Activity:
 If Jump:

Q1	Q2	Q3	Q4
Decode	Read literal 'n'	Process Data	Write to PC
No operation	No operation	No operation	No operation

If No Jump:

Q1	Q2	Q3	Q4
Decode	Read literal 'n'	Process Data	No operation

Example: HERE BNC Jump

Before Instruction
 PC = address (HERE)

After Instruction
 If Carry = 0;
 PC = address (Jump)
 If Carry = 1;
 PC = address (HERE+2)

BNN Branch if Not Negative

Syntax: [*label*] BNN n

Operands: $-128 \leq n \leq 127$

Operation: if negative bit is '0'
 $(PC) + 2 + 2n \rightarrow PC$

Status Affected: None

Encoding:

1110	0111	nnnn	nnnn
------	------	------	------

Description: If the Negative bit is '0', then the program will branch. The 2's complement number '2n' is added to the PC. Since the PC will have incremented to fetch the next instruction, the new address will be $PC+2+2n$. This instruction is then a two-cycle instruction.

Words: 1

Cycles: 1(2)

Q Cycle Activity:
 If Jump:

Q1	Q2	Q3	Q4
Decode	Read literal 'n'	Process Data	Write to PC
No operation	No operation	No operation	No operation

If No Jump:

Q1	Q2	Q3	Q4
Decode	Read literal 'n'	Process Data	No operation

Example: HERE BNN Jump

Before Instruction
 PC = address (HERE)

After Instruction
 If Negative = 0;
 PC = address (Jump)
 If Negative = 1;
 PC = address (HERE+2)

PIC18F1220/1320

BNOV Branch if Not Overflow

Syntax: [*label*] BNOV n
 Operands: $-128 \leq n \leq 127$
 Operation: if overflow bit is '0'
 (PC) + 2 + 2n → PC

Status Affected: None

Encoding:

1110	0101	nnnn	nnnn
------	------	------	------

Description: If the Overflow bit is '0', then the program will branch. The 2's complement number '2n' is added to the PC. Since the PC will have incremented to fetch the next instruction, the new address will be PC+2+2n. This instruction is then a two-cycle instruction.

Words: 1

Cycles: 1(2)

Q Cycle Activity:
If Jump:

Q1	Q2	Q3	Q4
Decode	Read literal 'n'	Process Data	Write to PC
No operation	No operation	No operation	No operation

If No Jump:

Q1	Q2	Q3	Q4
Decode	Read literal 'n'	Process Data	No operation

Example: HERE BNOV Jump

Before Instruction

PC = address (HERE)

After Instruction

If Overflow = 0;
 PC = address (Jump)
 If Overflow = 1;
 PC = address (HERE+2)

BNZ Branch if Not Zero

Syntax: [*label*] BNZ n
 Operands: $-128 \leq n \leq 127$
 Operation: if zero bit is '0'
 (PC) + 2 + 2n → PC

Status Affected: None

Encoding:

1110	0001	nnnn	nnnn
------	------	------	------

Description: If the Zero bit is '0', then the program will branch. The 2's complement number '2n' is added to the PC. Since the PC will have incremented to fetch the next instruction, the new address will be PC+2+2n. This instruction is then a two-cycle instruction.

Words: 1

Cycles: 1(2)

Q Cycle Activity:
If Jump:

Q1	Q2	Q3	Q4
Decode	Read literal 'n'	Process Data	Write to PC
No operation	No operation	No operation	No operation

If No Jump:

Q1	Q2	Q3	Q4
Decode	Read literal 'n'	Process Data	No operation

Example: HERE BNZ Jump

Before Instruction

PC = address (HERE)

After Instruction

If Zero = 0;
 PC = address (Jump)
 If Zero = 1;
 PC = address (HERE+2)

BRA Unconditional Branch

Syntax: [*label*] BRA n

Operands: $-1024 \leq n \leq 1023$

Operation: $(PC) + 2 + 2n \rightarrow PC$

Status Affected: None

Encoding:

1101	0nnn	nnnn	nnnn
------	------	------	------

Description: Add the 2's complement number '2n' to the PC. Since the PC will have incremented to fetch the next instruction, the new address will be $PC+2+2n$. This instruction is a two-cycle instruction.

Words: 1

Cycles: 2

Q Cycle Activity:

Q1	Q2	Q3	Q4
Decode	Read literal 'n'	Process Data	Write to PC
No operation	No operation	No operation	No operation

Example: HERE BRA Jump

Before Instruction
 PC = address (HERE)

After Instruction
 PC = address (Jump)

BSF Bit Set f

Syntax: [*label*] BSF f,b[,a]

Operands: $0 \leq f \leq 255$
 $0 \leq b \leq 7$
 $a \in [0,1]$

Operation: $1 \rightarrow f$

Status Affected: None

Encoding:

1000	bbba	ffff	ffff
------	------	------	------

Description: Bit 'b' in register 'f' is set. If 'a' is 0, Access Bank will be selected, overriding the BSR value. If 'a' = 1, then the bank will be selected as per the BSR value.

Words: 1

Cycles: 1

Q Cycle Activity:

Q1	Q2	Q3	Q4
Decode	Read register 'f'	Process Data	Write register 'f'

Example: BSF FLAG_REG, 7

Before Instruction
 FLAG_REG = 0x0A

After Instruction
 FLAG_REG = 0x8A

PIC18F1220/1320

BTFSK Bit Test File, Skip if Clear

Syntax: [*label*] BTFSK f,b[*a*]

Operands: $0 \leq f \leq 255$
 $0 \leq b \leq 7$
 $a \in [0,1]$

Operation: skip if (f) = 0

Status Affected: None

Encoding:

1011	bbba	ffff	ffff
------	------	------	------

Description: If bit 'b' in register 'f' is 0, then the next instruction is skipped.
 If bit 'b' is 0, then the next instruction fetched during the current instruction execution is discarded, and a NOP is executed instead, making this a two-cycle instruction. If 'a' is 0, the Access Bank will be selected, overriding the BSR value. If 'a' = 1, then the bank will be selected as per the BSR value (default).

Words: 1

Cycles: 1(2)
Note: 3 cycles if skip and followed by a 2-word instruction.

Q Cycle Activity:

Q1	Q2	Q3	Q4
Decode	Read register 'f'	Process Data	No operation

If skip:

Q1	Q2	Q3	Q4
No operation	No operation	No operation	No operation

If skip and followed by 2-word instruction:

Q1	Q2	Q3	Q4
No operation	No operation	No operation	No operation
No operation	No operation	No operation	No operation

Example: HERE BTFSK FLAG, 1
 FALSE :
 TRUE :

Before Instruction

PC = address (HERE)

After Instruction

If FLAG<1> = 0;
 PC = address (TRUE)
 If FLAG<1> = 1;
 PC = address (FALSE)

BTFSK Bit Test File, Skip if Set

Syntax: [*label*] BTFSK f,b[*a*]

Operands: $0 \leq f \leq 255$
 $0 \leq b < 7$
 $a \in [0,1]$

Operation: skip if (f) = 1

Status Affected: None

Encoding:

1010	bbba	ffff	ffff
------	------	------	------

Description: If bit 'b' in register 'f' is 1, then the next instruction is skipped.
 If bit 'b' is 1, then the next instruction fetched during the current instruction execution, is discarded and a NOP is executed instead, making this a two-cycle instruction. If 'a' is 0, the Access Bank will be selected, overriding the BSR value. If 'a' = 1, then the bank will be selected as per the BSR value (default).

Words: 1

Cycles: 1(2)
Note: 3 cycles if skip and followed by a 2-word instruction.

Q Cycle Activity:

Q1	Q2	Q3	Q4
Decode	Read register 'f'	Process Data	No operation

If skip:

Q1	Q2	Q3	Q4
No operation	No operation	No operation	No operation

If skip and followed by 2-word instruction:

Q1	Q2	Q3	Q4
No operation	No operation	No operation	No operation
No operation	No operation	No operation	No operation

Example: HERE BTFSK FLAG, 1
 FALSE :
 TRUE :

Before Instruction

PC = address (HERE)

After Instruction

If FLAG<1> = 0;
 PC = address (FALSE)
 If FLAG<1> = 1;
 PC = address (TRUE)

BTG Bit Toggle f

Syntax: [*label*] BTG f,b[,a]

Operands: $0 \leq f \leq 255$
 $0 \leq b < 7$
 $a \in [0,1]$

Operation: $\overline{f\langle b \rangle} \rightarrow f\langle b \rangle$

Status Affected: None

Encoding:

0111	bbba	ffff	ffff
------	------	------	------

Description: Bit 'b' in data memory location 'f' is inverted. If 'a' is 0, the Access Bank will be selected, overriding the BSR value. If 'a' = 1, then the bank will be selected as per the BSR value (default).

Words: 1

Cycles: 1

Q Cycle Activity:

Q1	Q2	Q3	Q4
Decode	Read register 'f'	Process Data	Write register 'f'

Example: BTG PORTB, 4

Before Instruction:

PORTB = 0111 0101 [0x75]

After Instruction:

PORTB = 0110 0101 [0x65]

BOV Branch if Overflow

Syntax: [*label*] BOV n

Operands: $-128 \leq n \leq 127$

Operation: if overflow bit is '1'
 $(PC) + 2 + 2n \rightarrow PC$

Status Affected: None

Encoding:

1110	0100	nnnn	nnnn
------	------	------	------

Description: If the Overflow bit is '1', then the program will branch. The 2's complement number '2n' is added to the PC. Since the PC will have incremented to fetch the next instruction, the new address will be $PC+2+2n$. This instruction is then a two-cycle instruction.

Words: 1

Cycles: 1(2)

Q Cycle Activity:

If Jump:

Q1	Q2	Q3	Q4
Decode	Read literal 'n'	Process Data	Write to PC
No operation	No operation	No operation	No operation

If No Jump:

Q1	Q2	Q3	Q4
Decode	Read literal 'n'	Process Data	No operation

Example: HERE BOV JUMP

Before Instruction

PC = address (HERE)

After Instruction

If Overflow = 1;
 PC = address (JUMP)
 If Overflow = 0;
 PC = address (HERE+2)

PIC18F1220/1320

BZ Branch if Zero

Syntax: [*label*] BZ n
 Operands: $-128 \leq n \leq 127$
 Operation: if Zero bit is '1'
 (PC) + 2 + 2n → PC

Status Affected: None

Encoding:

1110	0000	nnnn	nnnn
------	------	------	------

Description: If the Zero bit is '1', then the program will branch. The 2's complement number '2n' is added to the PC. Since the PC will have incremented to fetch the next instruction, the new address will be PC+2+2n. This instruction is then a two-cycle instruction.

Words: 1
 Cycles: 1(2)
 Q Cycle Activity:
 If Jump:

Q1	Q2	Q3	Q4
Decode	Read literal 'n'	Process Data	Write to PC
No operation	No operation	No operation	No operation

If No Jump:

Q1	Q2	Q3	Q4
Decode	Read literal 'n'	Process Data	No operation

Example: HERE BZ Jump

Before Instruction
 PC = address (HERE)
 After Instruction
 If Zero = 1;
 PC = address (Jump)
 If Zero = 0;
 PC = address (HERE+2)

CALL Subroutine Call

Syntax: [*label*] CALL k [,s]
 Operands: $0 \leq k \leq 1048575$
 $s \in [0,1]$

Operation: (PC) + 4 → TOS,
 k → PC<20:1>,
 if s = 1
 (W) → WS,
 (STATUS) → STATUSS,
 (BSR) → BSRS

Status Affected: None

Encoding:

1110	110s	k ₇ kkk	kkkk ₀
1111	k ₁₉ kkk	kkkk	kkkk ₈

Description: Subroutine call of entire 2 Mbyte memory range. First, return address (PC+ 4) is pushed onto the return stack. If 's' = 1, the W, STATUS and BSR registers are also pushed into their respective shadow registers, WS, STATUSS and BSRS. If 's' = 0, no update occurs (default). Then, the 20-bit value 'k' is loaded into PC<20:1>. CALL is a two-cycle instruction.

Words: 2
 Cycles: 2
 Q Cycle Activity:

Q1	Q2	Q3	Q4
Decode	Read literal 'k'<7:0>,	Push PC to stack	Read literal 'k'<19:8>, Write to PC
No operation	No operation	No operation	No operation

Example: HERE CALL THERE, FAST

Before Instruction
 PC = address (HERE)
 After Instruction
 PC = address (THERE)
 TOS = address (HERE + 4)
 WS = W
 BSRS = BSR
 STATUSS = STATUS

CLRF **Clear f**

Syntax: [*label*] CLRF f [,a]

Operands: $0 \leq f \leq 255$
 $a \in [0,1]$

Operation: 000h → f
 1 → Z

Status Affected: Z

Encoding:

0110	101a	ffff	ffff
------	------	------	------

Description: Clears the contents of the specified register. If 'a' is 0, the Access Bank will be selected, overriding the BSR value. If 'a' = 1, then the bank will be selected as per the BSR value (default).

Words: 1

Cycles: 1

Q Cycle Activity:

Q1	Q2	Q3	Q4
Decode	Read register 'f'	Process Data	Write register 'f'

Example: CLRF FLAG_REG

Before Instruction
 FLAG_REG = 0x5A

After Instruction
 FLAG_REG = 0x00

CLRWDT **Clear Watchdog Timer**

Syntax: [*label*] CLRWDT

Operands: None

Operation: 000h → WDT,
 000h → WDT postscaler,
 1 → \overline{TO} ,
 1 → PD

Status Affected: \overline{TO} , PD

Encoding:

0000	0000	0000	0100
------	------	------	------

Description: CLRWDT instruction resets the Watchdog Timer. It also resets the postscaler of the WDT. Status bits \overline{TO} and PD are set.

Words: 1

Cycles: 1

Q Cycle Activity:

Q1	Q2	Q3	Q4
Decode	No operation	Process Data	No operation

Example: CLRWDT

Before Instruction
 WDT Counter = ?

After Instruction
 WDT Counter = 0x00
 WDT Postscaler = 0
 \overline{TO} = 1
 PD = 1

PIC18F1220/1320

COMF **Complement f**

Syntax: [*label*] COMF f [,d [,a]

Operands: $0 \leq f \leq 255$
 $d \in [0,1]$
 $a \in [0,1]$

Operation: $(\bar{f}) \rightarrow \text{dest}$

Status Affected: N, Z

Encoding:

0001	11da	ffff	ffff
------	------	------	------

Description: The contents of register 'f' are complemented. If 'd' is 0, the result is stored in W. If 'd' is 1, the result is stored back in register 'f' (default). If 'a' is 0, the Access Bank will be selected, overriding the BSR value. If 'a' = 1, then the bank will be selected as per the BSR value (default).

Words: 1

Cycles: 1

Q Cycle Activity:

Q1	Q2	Q3	Q4
Decode	Read register 'f'	Process Data	Write to destination

Example: COMF REG, W

Before Instruction
REG = 0x13

After Instruction
REG = 0x13
W = 0xEC

CPFSEQ **Compare f with W, skip if f = W**

Syntax: [*label*] CPFSEQ f [,a]

Operands: $0 \leq f \leq 255$
 $a \in [0,1]$

Operation: (f) – (W),
skip if (f) = (W)
(unsigned comparison)

Status Affected: None

Encoding:

0110	001a	ffff	ffff
------	------	------	------

Description: Compares the contents of data memory location 'f' to the contents of W by performing an unsigned subtraction. If 'f' = W, then the fetched instruction is discarded and a NOP is executed instead, making this a two-cycle instruction. If 'a' is 0, the Access Bank will be selected, overriding the BSR value. If 'a' = 1, then the bank will be selected as per the BSR value (default).

Words: 1

Cycles: 1(2)
Note: 3 cycles if skip and followed by a 2-word instruction.

Q Cycle Activity:

Q1	Q2	Q3	Q4
Decode	Read register 'f'	Process Data	No operation

If skip:

Q1	Q2	Q3	Q4
No operation	No operation	No operation	No operation

If skip and followed by 2-word instruction:

Q1	Q2	Q3	Q4
No operation	No operation	No operation	No operation
No operation	No operation	No operation	No operation

Example: HERE CPFSEQ REG
 NEQUAL :
 EQUAL :

Before Instruction
PC Address = HERE
W = ?
REG = ?

After Instruction
If REG = W;
PC = Address (EQUAL)
If REG ≠ W;
PC = Address (NEQUAL)

CPFSGT Compare f with W, skip if f > W

Syntax: [label] CPFSGT f[,a]

Operands: $0 \leq f \leq 255$
 $a \in [0,1]$

Operation: (f) – (W),
 skip if (f) > (W)
 (unsigned comparison)

Status Affected: None

Encoding:

0110	010a	ffff	ffff
------	------	------	------

Description: Compares the contents of data memory location 'f' to the contents of the W by performing an unsigned subtraction. If the contents of 'f' are greater than the contents of WREG, then the fetched instruction is discarded and a NOP is executed instead, making this a two-cycle instruction. If 'a' is 0, the Access Bank will be selected, overriding the BSR value. If 'a' = 1, then the bank will be selected as per the BSR value (default).

Words: 1

Cycles: 1(2)
Note: 3 cycles if skip and followed by a 2-word instruction.

Q Cycle Activity:

Q1	Q2	Q3	Q4
Decode	Read register 'f'	Process Data	No operation

If skip:

Q1	Q2	Q3	Q4
No operation	No operation	No operation	No operation

If skip and followed by 2-word instruction:

Q1	Q2	Q3	Q4
No operation	No operation	No operation	No operation
No operation	No operation	No operation	No operation

Example:

```

HERE    CPFSGT REG
NGREATER :
GREATER :
    
```

Before Instruction

```

PC      = Address (HERE)
W       = ?
    
```

After Instruction

```

If REG  > W;
PC      = Address (GREATER)
If REG  ≤ W;
PC      = Address (NGREATER)
    
```

CPFSLT Compare f with W, skip if f < W

Syntax: [label] CPFSLT f[,a]

Operands: $0 \leq f \leq 255$
 $a \in [0,1]$

Operation: (f) – (W),
 skip if (f) < (W)
 (unsigned comparison)

Status Affected: None

Encoding:

0110	000a	ffff	ffff
------	------	------	------

Description: Compares the contents of data memory location 'f' to the contents of W by performing an unsigned subtraction. If the contents of 'f' are less than the contents of W, then the fetched instruction is discarded and a NOP is executed instead, making this a two-cycle instruction. If 'a' is 0, the Access Bank will be selected, overriding the BSR value. If 'a' is 1, the BSR will not be overridden (default).

Words: 1

Cycles: 1(2)
Note: 3 cycles if skip and followed by a 2-word instruction.

Q Cycle Activity:

Q1	Q2	Q3	Q4
Decode	Read register 'f'	Process Data	No operation

If skip:

Q1	Q2	Q3	Q4
No operation	No operation	No operation	No operation

If skip and followed by 2-word instruction:

Q1	Q2	Q3	Q4
No operation	No operation	No operation	No operation
No operation	No operation	No operation	No operation

Example:

```

HERE    CPFSLT REG
NLESS  :
LESS   :
    
```

Before Instruction

```

PC      = Address (HERE)
W       = ?
    
```

After Instruction

```

If REG  < W;
PC      = Address (LESS)
If REG  ≥ W;
PC      = Address (NLESS)
    
```

PIC18F1220/1320

DAW Decimal Adjust W Register

Syntax: [*label*] DAW

Operands: None

Operation: If [W<3:0> >9] or [DC = 1] then
(W<3:0>) + 6 → W<3:0>;
else
(W<3:0>) → W<3:0>;

If [W<7:4> >9] or [C = 1] then
(W<7:4>) + 6 → W<7:4>;
else
(W<7:4>) → W<7:4>;

Status Affected: C

Encoding:

0000	0000	0000	0111
------	------	------	------

Description: DAW adjusts the eight-bit value in W, resulting from the earlier addition of two variables (each in packed BCD format) and produces a correct packed BCD result.

Words: 1

Cycles: 1

Q Cycle Activity:

Q1	Q2	Q3	Q4
Decode	Read register W	Process Data	Write W

Example 1: DAW

Before Instruction

W = 0xA5
C = 0
DC = 0

After Instruction

W = 0x05
C = 1
DC = 0

Example 2:

Before Instruction

W = 0xCE
C = 0
DC = 0

After Instruction

W = 0x34
C = 1
DC = 0

DECF Decrement f

Syntax: [*label*] DECF f [,d [,a]]

Operands: $0 \leq f \leq 255$
 $d \in [0,1]$
 $a \in [0,1]$

Operation: $(f) - 1 \rightarrow \text{dest}$

Status Affected: C, DC, N, OV, Z

Encoding:

0000	01da	ffff	ffff
------	------	------	------

Description: Decrement register 'f'. If 'd' is 0, the result is stored in W. If 'd' is 1, the result is stored back in register 'f' (default). If 'a' is 0, the Access Bank will be selected, overriding the BSR value. If 'a' = 1, then the bank will be selected as per the BSR value (default).

Words: 1

Cycles: 1

Q Cycle Activity:

Q1	Q2	Q3	Q4
Decode	Read register 'f'	Process Data	Write to destination

Example: DECF CNT,

Before Instruction

CNT = 0x01
Z = 0

After Instruction

CNT = 0x00
Z = 1

DECFSZ **Decrement f, skip if 0**

Syntax: [*label*] DECFSZ f [,d [,a]]

Operands: $0 \leq f \leq 255$
 $d \in [0,1]$
 $a \in [0,1]$

Operation: $(f) - 1 \rightarrow \text{dest}$,
skip if result = 0

Status Affected: None

Encoding:

0010	11da	ffff	ffff
------	------	------	------

Description: The contents of register 'f' are decremented. If 'd' is 0, the result is placed in W. If 'd' is 1, the result is placed back in register 'f' (default). If the result is 0, the next instruction, which is already fetched, is discarded and a NOP is executed instead, making it a two-cycle instruction. If 'a' is 0, the Access Bank will be selected, overriding the BSR value. If 'a' = 1, then the bank will be selected as per the BSR value (default).

Words: 1

Cycles: 1(2)
Note: 3 cycles if skip and followed by a 2-word instruction.

Q Cycle Activity:

Q1	Q2	Q3	Q4
Decode	Read register 'f'	Process Data	Write to destination

If skip:

Q1	Q2	Q3	Q4
No operation	No operation	No operation	No operation

If skip and followed by 2-word instruction:

Q1	Q2	Q3	Q4
No operation	No operation	No operation	No operation
No operation	No operation	No operation	No operation

Example:

```

HERE      DECFSZ    CNT
            GOTO      LOOP
            CONTINUE
    
```

Before Instruction

PC = Address (HERE)

After Instruction

```

CNT = CNT - 1
If CNT = 0;
PC = Address (CONTINUE)
If CNT ≠ 0;
PC = Address (HERE+2)
    
```

DCFSNZ **Decrement f, skip if not 0**

Syntax: [*label*] DCFSNZ f [,d [,a]]

Operands: $0 \leq f \leq 255$
 $d \in [0,1]$
 $a \in [0,1]$

Operation: $(f) - 1 \rightarrow \text{dest}$,
skip if result ≠ 0

Status Affected: None

Encoding:

0100	11da	ffff	ffff
------	------	------	------

Description: The contents of register 'f' are decremented. If 'd' is 0, the result is placed in W. If 'd' is 1, the result is placed back in register 'f' (default). If the result is not 0, the next instruction, which is already fetched, is discarded, and a NOP is executed instead, making it a two-cycle instruction. If 'a' is 0, the Access Bank will be selected, overriding the BSR value. If 'a' = 1, then the bank will be selected as per the BSR value (default).

Words: 1

Cycles: 1(2)
Note: 3 cycles if skip and followed by a 2-word instruction.

Q Cycle Activity:

Q1	Q2	Q3	Q4
Decode	Read register 'f'	Process Data	Write to destination

If skip:

Q1	Q2	Q3	Q4
No operation	No operation	No operation	No operation

If skip and followed by 2-word instruction:

Q1	Q2	Q3	Q4
No operation	No operation	No operation	No operation
No operation	No operation	No operation	No operation

Example:

```

HERE      DCFSNZ    TEMP
ZERO      :
NZERO     :
    
```

Before Instruction

TEMP = ?

After Instruction

```

TEMP = TEMP - 1,
If TEMP = 0;
PC = Address (ZERO)
If TEMP ≠ 0;
PC = Address (NZERO)
    
```

PIC18F1220/1320

GOTO Unconditional Branch

Syntax: [*label*] GOTO *k*

Operands: $0 \leq k \leq 1048575$

Operation: $k \rightarrow PC<20:1>$

Status Affected: None

Encoding:

1st word ($k<7:0>$)	1110	1111	k_7 kkk	$kkkk_0$
2nd word ($k<19:8>$)	1111	k_{19} kkk	kkkk	$kkkk_8$

Description: GOTO allows an unconditional branch anywhere within entire 2 Mbyte memory range. The 20-bit value 'k' is loaded into PC<20:1>. GOTO is always a two-cycle instruction.

Words: 2

Cycles: 2

Q Cycle Activity:

Q1	Q2	Q3	Q4
Decode	Read literal 'k'<7:0>.	No operation	Read literal 'k'<19:8>, Write to PC
No operation	No operation	No operation	No operation

Example: GOTO THERE

After Instruction

PC = Address (THERE)

INCF Increment f

Syntax: [*label*] INCF *f* [,d [,a]]

Operands: $0 \leq f \leq 255$

$d \in [0,1]$

$a \in [0,1]$

Operation: $(f) + 1 \rightarrow \text{dest}$

Status Affected: C, DC, N, OV, Z

Encoding:

0010	10da	ffff	ffff
------	------	------	------

Description: The contents of register 'f' are incremented. If 'd' is 0, the result is placed in W. If 'd' is 1, the result is placed back in register 'f' (default). If 'a' is 0, the Access Bank will be selected, overriding the BSR value. If 'a' = 1, then the bank will be selected as per the BSR value (default).

Words: 1

Cycles: 1

Q Cycle Activity:

Q1	Q2	Q3	Q4
Decode	Read register 'f'	Process Data	Write to destination

Example: INCF CNT,

Before Instruction

CNT = 0xFF
 Z = 0
 C = ?
 DC = ?

After Instruction

CNT = 0x00
 Z = 1
 C = 1
 DC = 1

INCFSZ **Increment f, skip if 0**

Syntax: [*label*] INCFSZ f [,d [,a]]

Operands: $0 \leq f \leq 255$
 $d \in [0,1]$
 $a \in [0,1]$

Operation: $(f) + 1 \rightarrow \text{dest}$,
 skip if result = 0

Status Affected: None

Encoding:

0011	11da	ffff	ffff
------	------	------	------

Description: The contents of register 'f' are incremented. If 'd' is 0, the result is placed in W. If 'd' is 1, the result is placed back in register 'f' (default). If the result is 0, the next instruction, which is already fetched, is discarded and a NOP is executed instead, making it a two-cycle instruction. If 'a' is 0, the Access Bank will be selected, overriding the BSR value. If 'a' = 1, then the bank will be selected as per the BSR value (default).

Words: 1

Cycles: 1(2)
 Note: 3 cycles if skip and followed by a 2-word instruction.

Q Cycle Activity:

Q1	Q2	Q3	Q4
Decode	Read register 'f'	Process Data	Write to destination

If skip:

Q1	Q2	Q3	Q4
No operation	No operation	No operation	No operation

If skip and followed by 2-word instruction:

Q1	Q2	Q3	Q4
No operation	No operation	No operation	No operation
No operation	No operation	No operation	No operation

Example:

```

HERE    INCFSZ    CNT
NZERO    :
ZERO    :
```

Before Instruction

PC = Address (HERE)

After Instruction

```

CNT = CNT + 1
If CNT = 0;
PC = Address (ZERO)
If CNT ≠ 0;
PC = Address (NZERO)
```

INFSNZ **Increment f, skip if not 0**

Syntax: [*label*] INFSNZ f [,d [,a]]

Operands: $0 \leq f \leq 255$
 $d \in [0,1]$
 $a \in [0,1]$

Operation: $(f) + 1 \rightarrow \text{dest}$,
 skip if result ≠ 0

Status Affected: None

Encoding:

0100	10da	ffff	ffff
------	------	------	------

Description: The contents of register 'f' are incremented. If 'd' is 0, the result is placed in W. If 'd' is 1, the result is placed back in register 'f' (default). If the result is not 0, the next instruction, which is already fetched, is discarded and a NOP is executed instead, making it a two-cycle instruction. If 'a' is 0, the Access Bank will be selected, overriding the BSR value. If 'a' = 1, then the bank will be selected as per the BSR value (default).

Words: 1

Cycles: 1(2)
 Note: 3 cycles if skip and followed by a 2-word instruction.

Q Cycle Activity:

Q1	Q2	Q3	Q4
Decode	Read register 'f'	Process Data	Write to destination

If skip:

Q1	Q2	Q3	Q4
No operation	No operation	No operation	No operation

If skip and followed by 2-word instruction:

Q1	Q2	Q3	Q4
No operation	No operation	No operation	No operation
No operation	No operation	No operation	No operation

Example:

```

HERE    INFSNZ    REG
ZERO    :
NZERO    :
```

Before Instruction

PC = Address (HERE)

After Instruction

```

REG = REG + 1
If REG ≠ 0;
PC = Address (NZERO)
If REG = 0;
PC = Address (ZERO)
```

PIC18F1220/1320

IORLW Inclusive OR literal with W

Syntax: [*label*] IORLW k

Operands: $0 \leq k \leq 255$

Operation: (W) .OR. k \rightarrow W

Status Affected: N, Z

Encoding:

0000	1001	kkkk	kkkk
------	------	------	------

Description: The contents of W are OR'ed with the eight-bit literal 'k'. The result is placed in W.

Words: 1

Cycles: 1

Q Cycle Activity:

Q1	Q2	Q3	Q4
Decode	Read literal 'k'	Process Data	Write to W

Example: IORLW 0x35

Before Instruction

W = 0x9A

After Instruction

W = 0xBF

IORWF Inclusive OR W with f

Syntax: [*label*] IORWF f [,d [,a]]

Operands: $0 \leq f \leq 255$

$d \in [0,1]$

$a \in [0,1]$

Operation: (W) .OR. (f) \rightarrow dest

Status Affected: N, Z

Encoding:

0001	00da	ffff	ffff
------	------	------	------

Description: Inclusive OR W with register 'f'. If 'd' is 0, the result is placed in W. If 'd' is 1, the result is placed back in register 'f' (default). If 'a' is 0, the Access Bank will be selected, overriding the BSR value. If 'a' = 1, then the bank will be selected as per the BSR value (default).

Words: 1

Cycles: 1

Q Cycle Activity:

Q1	Q2	Q3	Q4
Decode	Read register 'f'	Process Data	Write to destination

Example: IORWF RESULT, W

Before Instruction

RESULT = 0x13

W = 0x91

After Instruction

RESULT = 0x13

W = 0x93

LFSR **Load FSR**

Syntax: [*label*] LFSR f,k

Operands: $0 \leq f \leq 2$
 $0 \leq k \leq 4095$

Operation: $k \rightarrow \text{FSRf}$

Status Affected: None

Encoding:

1110	1110	00ff	$k_{11}kkk$
1111	0000	k_7kkk	$kkkk$

Description: The 12-bit literal 'k' is loaded into the file select register pointed to by 'f'.

Words: 2

Cycles: 2

Q Cycle Activity:

Q1	Q2	Q3	Q4
Decode	Read literal 'k' MSB	Process Data	Write literal 'k' MSB to FSRfH
Decode	Read literal 'k' LSB	Process Data	Write literal 'k' to FSRfL

Example: LFSR 2, 0x3AB

After Instruction

FSR2H = 0x03
 FSR2L = 0xAB

MOVF **Move f**

Syntax: [*label*] MOVF f [,d [,a]]

Operands: $0 \leq f \leq 255$
 $d \in [0,1]$
 $a \in [0,1]$

Operation: $f \rightarrow \text{dest}$

Status Affected: N, Z

Encoding:

0101	00da	ffff	ffff
------	------	------	------

Description: The contents of register 'f' are moved to a destination dependent upon the status of 'd'. If 'd' is 0, the result is placed in W. If 'd' is 1, the result is placed back in register 'f' (default). Location 'f' can be anywhere in the 256-byte bank. If 'a' is 0, the Access Bank will be selected, overriding the BSR value. If 'a' = 1, then the bank will be selected as per the BSR value (default).

Words: 1

Cycles: 1

Q Cycle Activity:

Q1	Q2	Q3	Q4
Decode	Read register 'f'	Process Data	Write W

Example: MOVF REG, W

Before Instruction

REG = 0x22
 W = 0xFF

After Instruction

REG = 0x22
 W = 0x22

PIC18F1220/1320

MOVFF Move f to f

Syntax: [*label*] MOVFF *f_s*,*f_d*

Operands: $0 \leq f_s \leq 4095$
 $0 \leq f_d \leq 4095$

Operation: (*f_s*) → *f_d*

Status Affected: None

Encoding:

1st word (source)	1100	ffff	ffff	ffff _s
2nd word (destin.)	1111	ffff	ffff	ffff _d

Description: The contents of source register '*f_s*' are moved to destination register '*f_d*'. Location of source '*f_s*' can be anywhere in the 4096 byte data space (000h to FFFh) and location of destination '*f_d*' can also be anywhere from 000h to FFFh. Either source or destination can be W (a useful special situation). MOVFF is particularly useful for transferring a data memory location to a peripheral register (such as the transmit buffer or an I/O port). The MOVFF instruction cannot use the PCL, TOSU, TOSH or TOSL as the destination register. The MOVFF instruction should not be used to modify interrupt settings while any interrupt is enabled (see Page 75).

Words: 2

Cycles: 2 (3)

Q Cycle Activity:

Q1	Q2	Q3	Q4
Decode	Read register ' <i>f</i> ' (src)	Process Data	No operation
Decode	No operation No dummy read	No operation	Write register ' <i>f</i> ' (dest)

Example: MOVFF REG1, REG2

Before Instruction

REG1 = 0x33
 REG2 = 0x11

After Instruction

REG1 = 0x33
 REG2 = 0x33

MOVLB Move literal to low nibble in BSR

Syntax: [*label*] MOVLB *k*

Operands: $0 \leq k \leq 255$

Operation: *k* → BSR

Status Affected: None

Encoding:

0000	0001	kkkk	kkkk
------	------	------	------

Description: The 8-bit literal '*k*' is loaded into the Bank Select Register (BSR).

Words: 1

Cycles: 1

Q Cycle Activity:

Q1	Q2	Q3	Q4
Decode	Read literal ' <i>k</i> '	Process Data	Write literal ' <i>k</i> ' to BSR

Example: MOVLB 5

Before Instruction

BSR register = 0x02

After Instruction

BSR register = 0x05

MOVLW **Move literal to W**

Syntax: [*label*] MOVLW k

Operands: $0 \leq k \leq 255$

Operation: $k \rightarrow W$

Status Affected: None

Encoding:

0000	1110	kkkk	kkkk
------	------	------	------

Description: The eight-bit literal 'k' is loaded into W.

Words: 1

Cycles: 1

Q Cycle Activity:

Q1	Q2	Q3	Q4
Decode	Read literal 'k'	Process Data	Write to W

Example: MOVLW 0x5A

After Instruction

W = 0x5A

MOVWF **Move W to f**

Syntax: [*label*] MOVWF f [,a]

Operands: $0 \leq f \leq 255$
 $a \in [0,1]$

Operation: $(W) \rightarrow f$

Status Affected: None

Encoding:

0110	111a	ffff	ffff
------	------	------	------

Description: Move data from W to register 'f'. Location 'f' can be anywhere in the 256 byte bank. If 'a' is 0, the Access Bank will be selected, overriding the BSR value. If 'a' = 1, then the bank will be selected as per the BSR value (default).

Words: 1

Cycles: 1

Q Cycle Activity:

Q1	Q2	Q3	Q4
Decode	Read register 'f'	Process Data	Write register 'f'

Example: MOVWF REG

Before Instruction

W = 0x4F

REG = 0xFF

After Instruction

W = 0x4F

REG = 0x4F

PIC18F1220/1320

MULLW Multiply Literal with W

Syntax: [*label*] MULLW *k*

Operands: $0 \leq k \leq 255$

Operation: $(W) \times k \rightarrow \text{PRODH:PRODL}$

Status Affected: None

Encoding:

0000	1101	kkkk	kkkk
------	------	------	------

Description: An unsigned multiplication is carried out between the contents of W and the 8-bit literal 'k'. The 16-bit result is placed in PRODH:PRODL register pair. PRODH contains the high byte. W is unchanged. None of the status flags are affected. Note that neither overflow nor carry is possible in this operation. A zero result is possible but not detected.

Words: 1

Cycles: 1

Q Cycle Activity:

Q1	Q2	Q3	Q4
Decode	Read literal 'k'	Process Data	Write registers PRODH:PRODL

Example: MULLW 0xC4

Before Instruction

W = 0xE2
 PRODH = ?
 PRODL = ?

After Instruction

W = 0xE2
 PRODH = 0xAD
 PRODL = 0x08

MULWF Multiply W with f

Syntax: [*label*] MULWF *f* [,a]

Operands: $0 \leq f \leq 255$
 $a \in [0,1]$

Operation: $(W) \times (f) \rightarrow \text{PRODH:PRODL}$

Status Affected: None

Encoding:

0000	001a	ffff	ffff
------	------	------	------

Description: An unsigned multiplication is carried out between the contents of W and the register file location 'f'. The 16-bit result is stored in the PRODH:PRODL register pair. PRODH contains the high byte. Both W and 'f' are unchanged. None of the status flags are affected. Note that neither overflow nor carry is possible in this operation. A zero result is possible, but not detected. If 'a' is 0, the Access Bank will be selected, overriding the BSR value. If 'a' = 1, then the bank will be selected as per the BSR value (default).

Words: 1

Cycles: 1

Q Cycle Activity:

Q1	Q2	Q3	Q4
Decode	Read register 'f'	Process Data	Write registers PRODH:PRODL

Example: MULWF REG

Before Instruction

W = 0xC4
 REG = 0xB5
 PRODH = ?
 PRODL = ?

After Instruction

W = 0xC4
 REG = 0xB5
 PRODH = 0x8A
 PRODL = 0x94

NEGF **Negate f**

Syntax: [*label*] **NEGF** f [*a*]

Operands: $0 \leq f \leq 255$
 $a \in [0,1]$

Operation: $(\bar{f}) + 1 \rightarrow f$

Status Affected: N, OV, C, DC, Z

Encoding:

0110	110a	ffff	ffff
------	------	------	------

Description: Location 'f' is negated using two's complement. The result is placed in the data memory location 'f'. If 'a' is 0, the Access Bank will be selected, overriding the BSR value. If 'a' = 1, then the bank will be selected as per the BSR value.

Words: 1

Cycles: 1

Q Cycle Activity:

Q1	Q2	Q3	Q4
Decode	Read register 'f'	Process Data	Write register 'f'

Example: **NEGF** REG, 1

Before Instruction
REG = 0011 1010 [0x3A]

After Instruction
REG = 1100 0110 [0xC6]

NOP **No Operation**

Syntax: [*label*] **NOP**

Operands: None

Operation: No operation

Status Affected: None

Encoding:

0000	0000	0000	0000
1111	xxxx	xxxx	xxxx

Description: No operation.

Words: 1

Cycles: 1

Q Cycle Activity:

Q1	Q2	Q3	Q4
Decode	No operation	No operation	No operation

Example:

None.

PIC18F1220/1320

POP Pop Top of Return Stack

Syntax: [*label*] POP
 Operands: None
 Operation: (TOS) → bit bucket
 Status Affected: None
 Encoding:

0000	0000	0000	0110
------	------	------	------

 Description: The TOS value is pulled off the return stack and is discarded. The TOS value then becomes the previous value that was pushed onto the return stack.
 This instruction is provided to enable the user to properly manage the return stack to incorporate a software stack.
 Words: 1
 Cycles: 1

Q Cycle Activity:

Q1	Q2	Q3	Q4
Decode	No operation	POP TOS value	No operation

Example:

	POP	
	GOTO	NEW
Before Instruction		
TOS	=	0x0031A2
Stack (1 level down)	=	0x014332
After Instruction		
TOS	=	0x014332
PC	=	NEW

PUSH Push Top of Return Stack

Syntax: [*label*] PUSH
 Operands: None
 Operation: (PC+2) → TOS
 Status Affected: None
 Encoding:

0000	0000	0000	0101
------	------	------	------

 Description: The PC+2 is pushed onto the top of the return stack. The previous TOS value is pushed down on the stack. This instruction allows implementing a software stack by modifying TOS, and then pushing it onto the return stack.
 Words: 1
 Cycles: 1

Q Cycle Activity:

Q1	Q2	Q3	Q4
Decode	PUSH PC+2 onto return stack	No operation	No operation

Example:

		PUSH
Before Instruction		
TOS	=	0x00345A
PC	=	0x000124
After Instruction		
PC	=	0x000126
TOS	=	0x000126
Stack (1 level down)	=	0x00345A

RCALL **Relative Call**

Syntax: [*label*] RCALL n

Operands: -1024 ≤ n ≤ 1023

Operation: (PC) + 2 → TOS,
 (PC) + 2 + 2n → PC

Status Affected: None

Encoding:

1101	1nnn	nnnn	nnnn
------	------	------	------

Description: Subroutine call with a jump up to 1K from the current location. First, return address (PC+2) is pushed onto the stack. Then, add the 2's complement number '2n' to the PC. Since the PC will have incremented to fetch the next instruction, the new address will be PC+2+2n. This instruction is a two-cycle instruction.

Words: 1

Cycles: 2

Q Cycle Activity:

Q1	Q2	Q3	Q4
Decode	Read literal 'n' Push PC to stack	Process Data	Write to PC
No operation	No operation	No operation	No operation

Example: HERE RCALL Jump

Before Instruction

PC = Address (HERE)

After Instruction

PC = Address (Jump)
TOS = Address (HERE+2)

RESET **Reset**

Syntax: [*label*] RESET

Operands: None

Operation: Reset all registers and flags that are affected by a MCLR Reset.

Status Affected: All

Encoding:

0000	0000	1111	1111
------	------	------	------

Description: This instruction provides a way to execute a MCLR Reset in software.

Words: 1

Cycles: 1

Q Cycle Activity:

Q1	Q2	Q3	Q4
Decode	Start reset	No operation	No operation

Example: RESET

After Instruction

Registers = Reset Value
Flags* = Reset Value

PIC18F1220/1320

RETFIE Return from Interrupt

Syntax: [*label*] RETFIE [*s*]

Operands: $s \in [0,1]$

Operation: (TOS) → PC,
 1 → GIE/GIEH or PEIE/GIEL,
 if $s = 1$
 (WS) → W,
 (STATUS) → STATUS,
 (BSRS) → BSR,
 PCLATU, PCLATH are unchanged.

Status Affected: GIE/GIEH, PEIE/GIEL.

Encoding:

0000	0000	0001	000s
------	------	------	------

Description: Return from interrupt. Stack is popped and Top-of-Stack (TOS) is loaded into the PC. Interrupts are enabled by setting either the high or low priority global interrupt enable bit. If 's' = 1, the contents of the shadow registers WS, STATUS and BSRs are loaded into their corresponding registers, W, STATUS and BSR. If 's' = 0, no update of these registers occurs (default).

Words: 1

Cycles: 2

Q Cycle Activity:

Q1	Q2	Q3	Q4
Decode	No operation	No operation	pop PC from stack Set GIEH or GIEL
No operation	No operation	No operation	No operation

Example: RETFIE 1

After Interrupt

```

PC           = TOS
W            = WS
BSR         = BSRs
STATUS      = STATUS
GIE/GIEH, PEIE/GIEL = 1
    
```

RETLW Return Literal to W

Syntax: [*label*] RETLW *k*

Operands: $0 \leq k \leq 255$

Operation: $k \rightarrow W$,
 (TOS) → PC,
 PCLATU, PCLATH are unchanged

Status Affected: None

Encoding:

0000	1100	kkkk	kkkk
------	------	------	------

Description: W is loaded with the eight-bit literal 'k'. The program counter is loaded from the top of the stack (the return address). The high address latch (PCLATH) remains unchanged.

Words: 1

Cycles: 2

Q Cycle Activity:

Q1	Q2	Q3	Q4
Decode	Read literal 'k'	Process Data	pop PC from stack, Write to W
No operation	No operation	No operation	No operation

Example:

```

CALL TABLE ; W contains table
              ; offset value
              ; W now has
              ; table value
:
TABLE
ADDWF PCL   ; W = offset
RETLW k0   ; Begin table
RETLW k1   ;
:
RETLW kn   ; End of table
    
```

Before Instruction

W = 0x07

After Instruction

W = value of kn

RETURN Return from Subroutine

Syntax: [*label*] RETURN [*s*]

Operands: $s \in [0,1]$

Operation: (TOS) → PC,
if $s = 1$
(WS) → W,
(STATUS) → STATUS,
(BSRS) → BSR,
PCLATU, PCLATH are unchanged

Status Affected: None

Encoding:

0000	0000	0001	001s
------	------	------	------

Description: Return from subroutine. The stack is popped and the top of the stack (TOS) is loaded into the program counter. If 's' = 1, the contents of the shadow registers, WS, STATUS and BSRS are loaded into their corresponding registers, W, STATUS and BSR. If 's' = 0, no update of these registers occurs (default).

Words: 1
Cycles: 2
Q Cycle Activity:

	Q1	Q2	Q3	Q4
Decode	No operation	Process Data	pop PC from stack	
No operation	No operation	No operation	No operation	

Example: RETURN
After Interrupt
PC = TOS

RLCF Rotate Left f through Carry

Syntax: [*label*] RLCF f [,d [,a]]

Operands: $0 \leq f \leq 255$
 $d \in [0,1]$
 $a \in [0,1]$

Operation: (f<n>) → dest<n+1>,
(f<7>) → C,
(C) → dest<0>

Status Affected: C, N, Z

Encoding:

0011	01da	ffff	ffff
------	------	------	------

Description: The contents of register 'f' are rotated one bit to the left through the Carry Flag. If 'd' is 0, the result is placed in W. If 'd' is 1, the result is stored back in register 'f' (default). If 'a' is 0, the Access Bank will be selected, overriding the BSR value. If 'a' = 1, then the bank will be selected as per the BSR value (default).

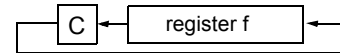

Words: 1
Cycles: 1
Q Cycle Activity:

	Q1	Q2	Q3	Q4
Decode	Read register 'f'	Process Data	Write to destination	

Example: RLCF REG, W

Before Instruction
REG = 1110 0110
C = 0

After Instruction
REG = 1110 0110
W = 1100 1100
C = 1

PIC18F1220/1320

RLNCF Rotate Left f (no carry)

Syntax: `[label] RLNCF f [,d [,a]]`

Operands: $0 \leq f \leq 255$
 $d \in [0,1]$
 $a \in [0,1]$

Operation: $(f\langle n \rangle) \rightarrow \text{dest}\langle n+1 \rangle$,
 $(f\langle 7 \rangle) \rightarrow \text{dest}\langle 0 \rangle$

Status Affected: N, Z

Encoding:

0100	01da	ffff	ffff
------	------	------	------

Description: The contents of register 'f' are rotated one bit to the left. If 'd' is 0, the result is placed in W. If 'd' is 1, the result is stored back in register 'f' (default). If 'a' is 0, the Access Bank will be selected, overriding the BSR value. If 'a' is 1, then the bank will be selected as per the BSR value (default).



Words: 1

Cycles: 1

Q Cycle Activity:

Q1	Q2	Q3	Q4
Decode	Read register 'f'	Process Data	Write to destination

Example: RLNCF REG

Before Instruction
 REG = 1010 1011
 After Instruction
 REG = 0101 0111

RRCF Rotate Right f through Carry

Syntax: `[label] RRCF f [,d [,a]]`

Operands: $0 \leq f \leq 255$
 $d \in [0,1]$
 $a \in [0,1]$

Operation: $(f\langle n \rangle) \rightarrow \text{dest}\langle n-1 \rangle$,
 $(f\langle 0 \rangle) \rightarrow C$,
 $(C) \rightarrow \text{dest}\langle 7 \rangle$

Status Affected: C, N, Z

Encoding:

0011	00da	ffff	ffff
------	------	------	------

Description: The contents of register 'f' are rotated one bit to the right through the Carry Flag. If 'd' is 0, the result is placed in W. If 'd' is 1, the result is placed back in register 'f' (default). If 'a' is 0, the Access Bank will be selected, overriding the BSR value. If 'a' is 1, then the bank will be selected as per the BSR value (default).

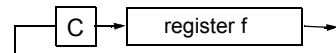

Words: 1

Cycles: 1

Q Cycle Activity:

Q1	Q2	Q3	Q4
Decode	Read register 'f'	Process Data	Write to destination

Example: RRCF REG, W

Before Instruction
 REG = 1110 0110
 C = 0
 After Instruction
 REG = 1110 0110
 W = 0111 0011
 C = 0

RRNCF Rotate Right f (no carry)

Syntax: `[label] RRNCF f[,d[,a]]`

Operands: $0 \leq f \leq 255$
 $d \in [0,1]$
 $a \in [0,1]$

Operation: $(f < n >) \rightarrow \text{dest} < n-1 >$,
 $(f < 0 >) \rightarrow \text{dest} < 7 >$

Status Affected: N, Z

Encoding:

0100	00da	ffff	ffff
------	------	------	------

Description: The contents of register 'f' are rotated one bit to the right. If 'd' is 0, the result is placed in W. If 'd' is 1, the result is placed back in register 'f' (default). If 'a' is 0, the Access Bank will be selected, overriding the BSR value. If 'a' is 1, then the bank will be selected as per the BSR value (default).



Words: 1

Cycles: 1

Q Cycle Activity:

Q1	Q2	Q3	Q4
Decode	Read register 'f'	Process Data	Write to destination

Example 1: `RRNCF REG, 1, 0`

Before Instruction
REG = 1101 0111

After Instruction
REG = 1110 1011

Example 2: `RRNCF REG, W`

Before Instruction
W = ?
REG = 1101 0111

After Instruction
W = 1110 1011
REG = 1101 0111

SETF Set f

Syntax: `[label] SETF f[,a]`

Operands: $0 \leq f \leq 255$
 $a \in [0,1]$

Operation: $\text{FFh} \rightarrow f$

Status Affected: None

Encoding:

0110	100a	ffff	ffff
------	------	------	------

Description: The contents of the specified register are set to FFh. If 'a' is 0, the Access Bank will be selected, overriding the BSR value. If 'a' is 1, then the bank will be selected as per the BSR value (default).

Words: 1

Cycles: 1

Q Cycle Activity:

Q1	Q2	Q3	Q4
Decode	Read register 'f'	Process Data	Write register 'f'

Example: `SETF REG`

Before Instruction
REG = 0x5A

After Instruction
REG = 0xFF

PIC18F1220/1320

SLEEP Enter SLEEP mode

Syntax: [*label*] SLEEP

Operands: None

Operation: 00h → WDT,
 0 → WDT postscaler,
 1 → \overline{TO} ,
 0 → \overline{PD}

Status Affected: \overline{TO} , \overline{PD}

Encoding:

0000	0000	0000	0011
------	------	------	------

Description: The power-down status bit (\overline{PD}) is cleared. The time-out status bit (\overline{TO}) is set. Watchdog Timer and its postscaler are cleared. The processor is put into SLEEP mode with the oscillator stopped.

Words: 1

Cycles: 1

Q Cycle Activity:

Q1	Q2	Q3	Q4
Decode	No operation	Process Data	Go to sleep

Example: SLEEP

Before Instruction

\overline{TO} = ?
 \overline{PD} = ?

After Instruction

\overline{TO} = 1 †
 \overline{PD} = 0

† If WDT causes wake-up, this bit is cleared.

SUBFWB Subtract f from W with borrow

Syntax: [*label*] SUBFWB f [,d [,a]]

Operands: $0 \leq f \leq 255$
 $d \in [0,1]$
 $a \in [0,1]$

Operation: $(W) - (f) - (\overline{C}) \rightarrow \text{dest}$

Status Affected: N, OV, C, DC, Z

Encoding:

0101	01da	ffff	ffff
------	------	------	------

Description: Subtract register 'f' and carry flag (borrow) from W (2's complement method). If 'd' is 0, the result is stored in W. If 'd' is 1, the result is stored in register 'f' (default). If 'a' is 0, the Access Bank will be selected, overriding the BSR value. If 'a' is 1, then the bank will be selected as per the BSR value (default).

Words: 1

Cycles: 1

Q Cycle Activity:

Q1	Q2	Q3	Q4
Decode	Read register 'f'	Process Data	Write to destination

Example 1: SUBFWB REG

Before Instruction

REG = 0x03
 W = 0x02
 C = 0x01

After Instruction

REG = 0xFF
 W = 0x02
 C = 0x00
 Z = 0x00
 N = 0x01 ; result is negative

Example 2: SUBFWB REG, 0, 0

Before Instruction

REG = 2
 W = 5
 C = 1

After Instruction

REG = 2
 W = 3
 C = 1
 Z = 0
 N = 0 ; result is positive

Example 3: SUBFWB REG, 1, 0

Before Instruction

REG = 1
 W = 2
 C = 0

After Instruction

REG = 0
 W = 2
 C = 1
 Z = 1 ; result is zero
 N = 0

SUBLW Subtract W from literal

Syntax: [label] SUBLW k

Operands: $0 \leq k \leq 255$

Operation: $k - (W) \rightarrow W$

Status Affected: N, OV, C, DC, Z

Encoding:

0000	1000	kkkk	kkkk
------	------	------	------

Description: W is subtracted from the eight-bit literal 'k'. The result is placed in W.

Words: 1

Cycles: 1

Q Cycle Activity:

Q1	Q2	Q3	Q4
Decode	Read literal 'k'	Process Data	Write to W

Example 1: SUBLW 0x02

Before Instruction

W = 1
C = ?

After Instruction

W = 1
C = 1 ; result is positive
Z = 0
N = 0

Example 2: SUBLW 0x02

Before Instruction

W = 2
C = ?

After Instruction

W = 0
C = 1 ; result is zero
Z = 1
N = 0

Example 3: SUBLW 0x02

Before Instruction

W = 3
C = ?

After Instruction

W = FF ; (2's complement)
C = 0 ; result is negative
Z = 0
N = 1

SUBWF Subtract W from f

Syntax: [label] SUBWF f[,d[,a]]

Operands: $0 \leq f \leq 255$
 $d \in [0,1]$
 $a \in [0,1]$

Operation: $(f) - (W) \rightarrow \text{dest}$

Status Affected: N, OV, C, DC, Z

Encoding:

0101	11da	ffff	ffff
------	------	------	------

Description: Subtract W from register 'f' (2's complement method). If 'd' is 0, the result is stored in W. If 'd' is 1, the result is stored back in register 'f' (default). If 'a' is 0, the Access Bank will be selected, overriding the BSR value. If 'a' is 1, then the bank will be selected as per the BSR value (default).

Words: 1

Cycles: 1

Q Cycle Activity:

Q1	Q2	Q3	Q4
Decode	Read register 'f'	Process Data	Write to destination

Example 1: SUBWF REG

Before Instruction

REG = 3
W = 2
C = ?

After Instruction

REG = 1
W = 2
C = 1 ; result is positive
Z = 0
N = 0

Example 2: SUBWF REG, W

Before Instruction

REG = 2
W = 2
C = ?

After Instruction

REG = 2
W = 0
C = 1 ; result is zero
Z = 1
N = 0

Example 3: SUBWF REG

Before Instruction

REG = 0x01
W = 0x02
C = ?

After Instruction

REG = 0xFFh ; (2's complement)
W = 0x02
C = 0x00 ; result is negative
Z = 0x00
N = 0x01

PIC18F1220/1320

SUBWFB Subtract W from f with Borrow

Syntax: `[label] SUBWFB f [,d [,a]]`

Operands: $0 \leq f \leq 255$
 $d \in [0,1]$
 $a \in [0,1]$

Operation: $(f) - (W) - (\overline{C}) \rightarrow \text{dest}$

Status Affected: N, OV, C, DC, Z

Encoding:

0101	10da	ffff	ffff
------	------	------	------

Description: Subtract W and the carry flag (borrow) from register 'f' (2's complement method). If 'd' is 0, the result is stored in W. If 'd' is 1, the result is stored back in register 'f' (default). If 'a' is 0, the Access Bank will be selected, overriding the BSR value. If 'a' is 1, then the bank will be selected as per the BSR value (default).

Words: 1

Cycles: 1

Q Cycle Activity:

Q1	Q2	Q3	Q4
Decode	Read register 'f'	Process Data	Write to destination

Example 1: `SUBWFB REG, 1, 0`

Before Instruction

REG = 0x19 (0001 1001)
W = 0x0D (0000 1101)
C = 0x01

After Instruction

REG = 0x0C (0000 1011)
W = 0x0D (0000 1101)
C = 0x01
Z = 0x00
N = 0x00 ; result is positive

Example 2: `SUBWFB REG, 0, 0`

Before Instruction

REG = 0x1B (0001 1011)
W = 0x1A (0001 1010)
C = 0x00

After Instruction

REG = 0x1B (0001 1011)
W = 0x00
C = 0x01
Z = 0x01 ; result is zero
N = 0x00

Example 3: `SUBWFB REG, 1, 0`

Before Instruction

REG = 0x03 (0000 0011)
W = 0x0E (0000 1101)
C = 0x01

After Instruction

REG = 0xF5 (1111 0100)
; [2's comp]
W = 0x0E (0000 1101)
C = 0x00
Z = 0x00
N = 0x01 ; result is negative

SWAPF Swap f

Syntax: `[label] SWAPF f [,d [,a]]`

Operands: $0 \leq f \leq 255$
 $d \in [0,1]$
 $a \in [0,1]$

Operation: $(f<3:0>) \rightarrow \text{dest}<7:4>$,
 $(f<7:4>) \rightarrow \text{dest}<3:0>$

Status Affected: None

Encoding:

0011	10da	ffff	ffff
------	------	------	------

Description: The upper and lower nibbles of register 'f' are exchanged. If 'd' is 0, the result is placed in W. If 'd' is 1, the result is placed in register 'f' (default). If 'a' is 0, the Access Bank will be selected, overriding the BSR value. If 'a' is 1, then the bank will be selected as per the BSR value (default).

Words: 1

Cycles: 1

Q Cycle Activity:

Q1	Q2	Q3	Q4
Decode	Read register 'f'	Process Data	Write to destination

Example: `SWAPF REG`

Before Instruction

REG = 0x53

After Instruction

REG = 0x35

TBLRD **Table Read**

Syntax: [*label*] TBLRD (*; *+; *-; +*)

Operands: None

Operation: if TBLRD *,
 (Prog Mem (TBLPTR)) → TABLAT;
 TBLPTR - No Change;
 if TBLRD *+,
 (Prog Mem (TBLPTR)) → TABLAT;
 (TBLPTR) +1 → TBLPTR;
 if TBLRD *-,
 (Prog Mem (TBLPTR)) → TABLAT;
 (TBLPTR) -1 → TBLPTR;
 if TBLRD +*,
 (TBLPTR) +1 → TBLPTR;
 (Prog Mem (TBLPTR)) → TABLAT;

Status Affected: None

Encoding:

0000	0000	0000	10nn nn=0 * =1 *+ =2 *- =3 +*
------	------	------	---

Description: This instruction is used to read the contents of Program Memory (P.M.). To address the program memory, a pointer called Table Pointer (TBLPTR) is used. The TBLPTR (a 21-bit pointer) points to each byte in the program memory. TBLPTR has a 2 Mbyte address range.

 TBLPTR[0] = 0: Least Significant Byte of Program Memory Word

 TBLPTR[0] = 1: Most Significant Byte of Program Memory Word

The TBLRD instruction can modify the value of TBLPTR as follows:

- no change
- post-increment
- post-decrement
- pre-increment

Words: 1

Cycles: 2

Q Cycle Activity:

	Q1	Q2	Q3	Q4
Decode	No operation	No operation	No operation	No operation
No operation	No operation (Read Program Memory)	No operation	No operation	No operation (Write TABLAT)

TBLRD **Table Read (Continued)**

Example1: TBLRD *+ ;

 Before Instruction

 TABLAT = 0x55

 TBLPTR = 0x00A356

 MEMORY(0x00A356) = 0x34

 After Instruction

 TABLAT = 0x34

 TBLPTR = 0x00A357

Example2: TBLRD +* ;

 Before Instruction

 TABLAT = 0xAA

 TBLPTR = 0x01A357

 MEMORY(0x01A357) = 0x12

 MEMORY(0x01A358) = 0x34

 After Instruction

 TABLAT = 0x34

 TBLPTR = 0x01A358

PIC18F1220/1320

TBLWT Table Write

Syntax: [*label*] TBLWT (*; *+; *-; +*)

Operands: None

Operation: if TBLWT*,
(TABLAT) → Holding Register;
TBLPTR - No Change;
if TBLWT*+,
(TABLAT) → Holding Register;
(TBLPTR) +1 → TBLPTR;
if TBLWT*-,
(TABLAT) → Holding Register;
(TBLPTR) -1 → TBLPTR;
if TBLWT*+,
(TBLPTR) +1 → TBLPTR;
(TABLAT) → Holding Register;

Status Affected: None

Encoding:

0000	0000	0000	11nn nn=0 * =1 *+ =2 *- =3 +*
------	------	------	---

Description: This instruction uses the 3 LSBs of TBLPTR to determine which of the 8 holding registers the TABLAT is written to. The holding registers are used to program the contents of Program Memory (P.M.). (Refer to Section 6.0 for additional details on programming FLASH memory.) The TBLPTR (a 21-bit pointer) points to each byte in the program memory. TBLPTR has a 2 MByte address range. The LSb of the TBLPTR selects which byte of the program memory location to access.

TBLPTR[0] = 0: Least Significant Byte of Program Memory Word

TBLPTR[0] = 1: Most Significant Byte of Program Memory Word

The TBLWT instruction can modify the value of TBLPTR as follows:

- no change
- post-increment
- post-decrement
- pre-increment

TBLWT Table Write (Continued)

Words: 1

Cycles: 2

Q Cycle Activity:

Q1	Q2	Q3	Q4
Decode	No operation	No operation	No operation
No operation	No operation (Read TABLAT)	No operation	No operation (Write to Holding Register)

Example 1: TBLWT *+;

Before Instruction

TABLAT = 0x55
TBLPTR = 0x00A356
HOLDING REGISTER (0x00A356) = 0xFF

After Instructions (table write completion)

TABLAT = 0x55
TBLPTR = 0x00A357
HOLDING REGISTER (0x00A356) = 0x55

Example 2: TBLWT +*;

Before Instruction

TABLAT = 0x34
TBLPTR = 0x01389A
HOLDING REGISTER (0x01389A) = 0xFF
HOLDING REGISTER (0x01389B) = 0xFF

After Instruction (table write completion)

TABLAT = 0x34
TBLPTR = 0x01389B
HOLDING REGISTER (0x01389A) = 0xFF
HOLDING REGISTER (0x01389B) = 0x34

TSTFSZ Test f, skip if 0

Syntax: [*label*] TSTFSZ f [,a]

Operands: $0 \leq f \leq 255$
 $a \in [0,1]$

Operation: skip if $f = 0$

Status Affected: None

Encoding:

0110	011a	ffff	ffff
------	------	------	------

Description: If 'f' = 0, the next instruction, fetched during the current instruction execution is discarded and a NOP is executed, making this a two-cycle instruction. If 'a' is 0, the Access Bank will be selected, overriding the BSR value. If 'a' is 1, then the bank will be selected as per the BSR value (default).

Words: 1

Cycles: 1(2)

Note: 3 cycles if skip and followed by a 2-word instruction.

Q Cycle Activity:

Q1	Q2	Q3	Q4
Decode	Read register 'f'	Process Data	No operation

If skip:

Q1	Q2	Q3	Q4
No operation	No operation	No operation	No operation

If skip and followed by 2-word instruction:

Q1	Q2	Q3	Q4
No operation	No operation	No operation	No operation
No operation	No operation	No operation	No operation

Example:

```

HERE    TSTFSZ  CNT
NZERO   :
ZERO    :
```

Before Instruction

PC = Address (HERE)

After Instruction

```

If CNT = 0x00,
PC      = Address (ZERO)
If CNT ≠ 0x00,
PC      = Address (NZERO)
```

XORLW Exclusive OR literal with W

Syntax: [*label*] XORLW k

Operands: $0 \leq k \leq 255$

Operation: (W) .XOR. k → W

Status Affected: N, Z

Encoding:

0000	1010	kkkk	kkkk
------	------	------	------

Description: The contents of W are XORed with the 8-bit literal 'k'. The result is placed in W.

Words: 1

Cycles: 1

Q Cycle Activity:

Q1	Q2	Q3	Q4
Decode	Read literal 'k'	Process Data	Write to W

Example: XORLW 0xAF

Before Instruction

W = 0xB5

After Instruction

W = 0x1A

PIC18F1220/1320

XORWF Exclusive OR W with f

Syntax: [*label*] XORWF f [,d [,a]]

Operands: $0 \leq f \leq 255$
 $d \in [0,1]$
 $a \in [0,1]$

Operation: (W) .XOR. (f) → dest

Status Affected: N, Z

Encoding:

0001	10da	ffff	ffff
------	------	------	------

Description: Exclusive OR the contents of W with register 'f'. If 'd' is 0, the result is stored in W. If 'd' is 1, the result is stored back in the register 'f' (default). If 'a' is 0, the Access Bank will be selected, overriding the BSR value. If 'a' is 1, then the bank will be selected as per the BSR value (default).

Words: 1

Cycles: 1

Q Cycle Activity:

Q1	Q2	Q3	Q4
Decode	Read register 'f'	Process Data	Write to destination

Example: XORWF REG

Before Instruction

REG = 0xAF
W = 0xB5

After Instruction

REG = 0x1A
W = 0xB5

21.0 DEVELOPMENT SUPPORT

The PICmicro[®] microcontrollers are supported with a full range of hardware and software development tools:

- Integrated Development Environment
 - MPLAB[®] IDE Software
- Assemblers/Compilers/Linkers
 - MPASM[™] Assembler
 - MPLAB C17 and MPLAB C18 C Compilers
 - MPLINK[™] Object Linker/
MPLIB[™] Object Librarian
- Simulators
 - MPLAB SIM Software Simulator
- Emulators
 - MPLAB ICE 2000 In-Circuit Emulator
 - ICEPIC[™] In-Circuit Emulator
- In-Circuit Debugger
 - MPLAB ICD
- Device Programmers
 - PRO MATE[®] II Universal Device Programmer
 - PICSTART[®] Plus Entry-Level Development Programmer
- Low Cost Demonstration Boards
 - PICDEM[™] 1 Demonstration Board
 - PICDEM 2 Demonstration Board
 - PICDEM 3 Demonstration Board
 - PICDEM 17 Demonstration Board
 - KEELOQ[®] Demonstration Board

21.1 MPLAB Integrated Development Environment Software

The MPLAB IDE software brings an ease of software development previously unseen in the 8-bit microcontroller market. The MPLAB IDE is a Windows[®]-based application that contains:

- An interface to debugging tools
 - simulator
 - programmer (sold separately)
 - emulator (sold separately)
 - in-circuit debugger (sold separately)
- A full-featured editor
- A project manager
- Customizable toolbar and key mapping
- A status bar
- On-line help

The MPLAB IDE allows you to:

- Edit your source files (either assembly or 'C')
- One touch assemble (or compile) and download to PICmicro emulator and simulator tools (automatically updates all project information)
- Debug using:
 - source files
 - absolute listing file
 - machine code

The ability to use MPLAB IDE with multiple debugging tools allows users to easily switch from the cost-effective simulator to a full-featured emulator with minimal retraining.

21.2 MPASM Assembler

The MPASM assembler is a full-featured universal macro assembler for all PICmicro MCU's.

The MPASM assembler has a command line interface and a Windows shell. It can be used as a stand-alone application on a Windows 3.x or greater system, or it can be used through MPLAB IDE. The MPASM assembler generates relocatable object files for the MPLINK object linker, Intel[®] standard HEX files, MAP files to detail memory usage and symbol reference, an absolute LST file that contains source lines and generated machine code, and a COD file for debugging.

The MPASM assembler features include:

- Integration into MPLAB IDE projects.
- User-defined macros to streamline assembly code.
- Conditional assembly for multi-purpose source files.
- Directives that allow complete control over the assembly process.

21.3 MPLAB C17 and MPLAB C18 C Compilers

The MPLAB C17 and MPLAB C18 Code Development Systems are complete ANSI 'C' compilers for Microchip's PIC17CXXX and PIC18CXXX family of microcontrollers, respectively. These compilers provide powerful integration capabilities and ease of use not found with other compilers.

For easier source level debugging, the compilers provide symbol information that is compatible with the MPLAB IDE memory display.

PIC18F1220/1320

21.4 MPLINK Object Linker/ MPLIB Object Librarian

The MPLINK object linker combines relocatable objects created by the MPASM assembler and the MPLAB C17 and MPLAB C18 C compilers. It can also link relocatable objects from pre-compiled libraries, using directives from a linker script.

The MPLIB object librarian is a librarian for pre-compiled code to be used with the MPLINK object linker. When a routine from a library is called from another source file, only the modules that contain that routine will be linked in with the application. This allows large libraries to be used efficiently in many different applications. The MPLIB object librarian manages the creation and modification of library files.

The MPLINK object linker features include:

- Integration with MPASM assembler and MPLAB C17 and MPLAB C18 C compilers.
- Allows all memory areas to be defined as sections to provide link-time flexibility.

The MPLIB object librarian features include:

- Easier linking because single libraries can be included instead of many smaller files.
- Helps keep code maintainable by grouping related modules together.
- Allows libraries to be created and modules to be added, listed, replaced, deleted or extracted.

21.5 MPLAB SIM Software Simulator

The MPLAB SIM software simulator allows code development in a PC-hosted environment by simulating the PICmicro series microcontrollers on an instruction level. On any given instruction, the data areas can be examined or modified and stimuli can be applied from a file, or user-defined key press, to any of the pins. The execution can be performed in single step, execute until break, or trace mode.

The MPLAB SIM simulator fully supports symbolic debugging using the MPLAB C17 and the MPLAB C18 C compilers and the MPASM assembler. The software simulator offers the flexibility to develop and debug code outside of the laboratory environment, making it an excellent multi-project software development tool.

21.6 MPLAB ICE High Performance Universal In-Circuit Emulator with MPLAB IDE

The MPLAB ICE universal in-circuit emulator is intended to provide the product development engineer with a complete microcontroller design tool set for PICmicro microcontrollers (MCUs). Software control of the MPLAB ICE in-circuit emulator is provided by the MPLAB Integrated Development Environment (IDE), which allows editing, building, downloading and source debugging from a single environment.

The MPLAB ICE 2000 is a full-featured emulator system with enhanced trace, trigger and data monitoring features. Interchangeable processor modules allow the system to be easily reconfigured for emulation of different processors. The universal architecture of the MPLAB ICE in-circuit emulator allows expansion to support new PICmicro microcontrollers.

The MPLAB ICE in-circuit emulator system has been designed as a real-time emulation system, with advanced features that are generally found on more expensive development tools. The PC platform and Microsoft® Windows environment were chosen to best make these features available to you, the end user.

21.7 ICEPIC In-Circuit Emulator

The ICEPIC low cost, in-circuit emulator is a solution for the Microchip Technology PIC16C5X, PIC16C6X, PIC16C7X and PIC16CXXX families of 8-bit One-Time-Programmable (OTP) microcontrollers. The modular system can support different subsets of PIC16C5X or PIC16CXXX products through the use of interchangeable personality modules, or daughter boards. The emulator is capable of emulating without target application circuitry being present.

21.8 MPLAB ICD In-Circuit Debugger

Microchip's In-Circuit Debugger, MPLAB ICD, is a powerful, low cost, run-time development tool. This tool is based on the FLASH PICmicro MCUs and can be used to develop for this and other PICmicro microcontrollers. The MPLAB ICD utilizes the in-circuit debugging capability built into the FLASH devices. This feature, along with Microchip's In-Circuit Serial Programming™ protocol, offers cost-effective in-circuit FLASH debugging from the graphical user interface of the MPLAB Integrated Development Environment. This enables a designer to develop and debug source code by watching variables, single-stepping and setting break points. Running at full speed enables testing hardware in real-time.

21.9 PRO MATE II Universal Device Programmer

The PRO MATE II universal device programmer is a full-featured programmer, capable of operating in stand-alone mode, as well as PC-hosted mode. The PRO MATE II device programmer is CE compliant.

The PRO MATE II device programmer has programmable VDD and VPP supplies, which allow it to verify programmed memory at VDD min and VDD max for maximum reliability. It has an LCD display for instructions and error messages, keys to enter commands and a modular detachable socket assembly to support various package types. In stand-alone mode, the PRO MATE II device programmer can read, verify, or program PICmicro devices. It can also set code protection in this mode.

21.10 PICSTART Plus Entry Level Development Programmer

The PICSTART Plus development programmer is an easy-to-use, low cost, prototype programmer. It connects to the PC via a COM (RS-232) port. MPLAB Integrated Development Environment software makes using the programmer simple and efficient.

The PICSTART Plus development programmer supports all PICmicro devices with up to 40 pins. Larger pin count devices, such as the PIC16C92X and PIC17C76X, may be supported with an adapter socket. The PICSTART Plus development programmer is CE compliant.

21.11 PICDEM 1 Low Cost PICmicro Demonstration Board

The PICDEM 1 demonstration board is a simple board which demonstrates the capabilities of several of Microchip's microcontrollers. The microcontrollers supported are: PIC16C5X (PIC16C54 to PIC16C58A), PIC16C61, PIC16C62X, PIC16C71, PIC16C8X, PIC17C42, PIC17C43 and PIC17C44. All necessary hardware and software is included to run basic demo programs. The user can program the sample microcontrollers provided with the PICDEM 1 demonstration board on a PRO MATE II device programmer, or a PICSTART Plus development programmer, and easily test firmware. The user can also connect the PICDEM 1 demonstration board to the MPLAB ICE in-circuit emulator and download the firmware to the emulator for testing. A prototype area is available for the user to build some additional hardware and connect it to the microcontroller socket(s). Some of the features include an RS-232 interface, a potentiometer for simulated analog input, push button switches and eight LEDs connected to PORTB.

21.12 PICDEM 2 Low Cost PIC16CXX Demonstration Board

The PICDEM 2 demonstration board is a simple demonstration board that supports the PIC16C62, PIC16C64, PIC16C65, PIC16C73 and PIC16C74 microcontrollers. All the necessary hardware and software is included to run the basic demonstration programs. The user can program the sample microcontrollers provided with the PICDEM 2 demonstration board on a PRO MATE II device programmer, or a PICSTART Plus development programmer, and easily test firmware. The MPLAB ICE in-circuit emulator may also be used with the PICDEM 2 demonstration board to test firmware. A prototype area has been provided to the user for adding additional hardware and connecting it to the microcontroller socket(s). Some of the features include a RS-232 interface, push button switches, a potentiometer for simulated analog input, a serial EEPROM to demonstrate usage of the I²C™ bus and separate headers for connection to an LCD module and a keypad.

PIC18F1220/1320

21.13 PICDEM 3 Low Cost PIC16CXXX Demonstration Board

The PICDEM 3 demonstration board is a simple demonstration board that supports the PIC16C923 and PIC16C924 in the PLCC package. It will also support future 44-pin PLCC microcontrollers with an LCD Module. All the necessary hardware and software is included to run the basic demonstration programs. The user can program the sample microcontrollers provided with the PICDEM 3 demonstration board on a PRO MATE II device programmer, or a PICSTART Plus development programmer with an adapter socket, and easily test firmware. The MPLAB ICE in-circuit emulator may also be used with the PICDEM 3 demonstration board to test firmware. A prototype area has been provided to the user for adding hardware and connecting it to the microcontroller socket(s). Some of the features include a RS-232 interface, push button switches, a potentiometer for simulated analog input, a thermistor and separate headers for connection to an external LCD module and a keypad. Also provided on the PICDEM 3 demonstration board is a LCD panel, with 4 commons and 12 segments, that is capable of displaying time, temperature and day of the week. The PICDEM 3 demonstration board provides an additional RS-232 interface and Windows software for showing the demultiplexed LCD signals on a PC. A simple serial interface allows the user to construct a hardware demultiplexer for the LCD signals.

21.14 PICDEM 17 Demonstration Board

The PICDEM 17 demonstration board is an evaluation board that demonstrates the capabilities of several Microchip microcontrollers, including PIC17C752, PIC17C756A, PIC17C762 and PIC17C766. All necessary hardware is included to run basic demo programs, which are supplied on a 3.5-inch disk. A programmed sample is included and the user may erase it and program it with the other sample programs using the PRO MATE II device programmer, or the PICSTART Plus development programmer, and easily debug and test the sample code. In addition, the PICDEM 17 demonstration board supports downloading of programs to and executing out of external FLASH memory on board. The PICDEM 17 demonstration board is also usable with the MPLAB ICE in-circuit emulator, or the PICMASTER emulator and all of the sample programs can be run and modified using either emulator. Additionally, a generous prototype area is available for user hardware.

21.15 KEELOQ Evaluation and Programming Tools

KEELOQ evaluation and programming tools support Microchip's HCS Secure Data Products. The HCS evaluation kit includes a LCD display to show changing codes, a decoder to decode transmissions and a programming interface to program test transmitters.

TABLE 21-1: DEVELOPMENT TOOLS FROM MICROCHIP

Development Tool	PIC12CXX	PIC1400	PIC16C5X	PIC16C6X	PIC16CXX	PIC16F62X	PIC16C7X	PIC16C7XX	PIC16C8X/ PIC16F8X	PIC16F8XX	PIC16C9XX	PIC17C4X	PIC17C7XX	PIC18CXX2	PIC18FXX	24CXX/ 25CXX/ 93CXX	HCSXX	MCRFXXX	MCP2510
Software Tools																			
MPLAB® Integrated Development Environment	✓	✓	✓	✓	✓	✓	✓	✓	✓	✓	✓	✓	✓	✓	✓	✓	✓	✓	✓
MPLAB® C17 C Compiler																			
MPLAB® C18 C Compiler																			
MPASM™ Assembler/ MPLINK™ Object Linker	✓	✓	✓	✓	✓	✓	✓	✓	✓	✓	✓	✓	✓	✓	✓	✓	✓	✓	✓
MPLAB® ICE In-Circuit Emulator	✓	✓	✓	✓	✓	✓	✓	✓	✓	✓	✓	✓	✓	✓	✓	✓	✓	✓	✓
Emulators																			
ICEPIC™ In-Circuit Emulator	✓		✓	✓	✓		✓	✓	✓	✓	✓								
Debugger																			
MPLAB® ICD In-Circuit Debugger				✓			✓			✓					✓				
Programmers																			
PICSTART® Plus Entry Level Development Programmer	✓	✓	✓	✓	✓	✓	✓	✓	✓	✓	✓	✓	✓	✓	✓	✓	✓	✓	✓
PRO MATE® II Universal Device Programmer	✓	✓	✓	✓	✓	✓	✓	✓	✓	✓	✓	✓	✓	✓	✓	✓	✓	✓	✓
Program Boards and Eval Kits																			
PICDEM™ 1 Demonstration Board			✓		✓		†		✓										
PICDEM™ 2 Demonstration Board				†			†							✓					
PICDEM™ 3 Demonstration Board										✓									
PICDEM™ 14A Demonstration Board		✓																	
PICDEM™ 17 Demonstration Board												✓							
KEELOQ® Evaluation Kit																	✓		
KEELOQ® Transponder Kit																	✓		
microID™ Programmer's Kit																		✓	
125 kHz microID™ Developer's Kit																		✓	
125 kHz Anticollision microID™ Developer's Kit																		✓	
13.56 MHz Anticollision microID™ Developer's Kit																		✓	
MCP2510 CAN Developer's Kit																		✓	✓

* Contact the Microchip Technology Inc. web site at www.microchip.com for information on how to use the MPLAB® ICD In-Circuit Debugger (DV164001) with PIC16C62, 63, 64, 65, 72, 73, 74, 76, 77.

** Contact Microchip Technology Inc. for availability date.

† Development tool is available on select devices.

PIC18F1220/1320

NOTES:

22.0 ELECTRICAL CHARACTERISTICS

Absolute Maximum Ratings †

Ambient temperature under bias.....	-55°C to +125°C
Storage temperature	-65°C to +150°C
Voltage on any pin with respect to V _{SS} (except V _{DD} , $\overline{\text{MCLR}}$, and RA4)	-0.3V to (V _{DD} + 0.3V)
Voltage on V _{DD} with respect to V _{SS}	-0.3V to +7.5V
Voltage on $\overline{\text{MCLR}}$ with respect to V _{SS} (Note 2)	0V to +13.25V
Voltage on RA4 with respect to V _{SS}	0V to +8.5V
Total power dissipation (Note 1)	1.0W
Maximum current out of V _{SS} pin	300 mA
Maximum current into V _{DD} pin	250 mA
Input clamp current, I _{IK} (V _I < 0 or V _I > V _{DD}).....	±20 mA
Output clamp current, I _{OK} (V _O < 0 or V _O > V _{DD}).....	±20 mA
Maximum output current sunk by any I/O pin.....	25 mA
Maximum output current sourced by any I/O pin	25 mA
Maximum current sunk by all ports	200 mA
Maximum current sourced by all ports	200 mA

Note 1: Power dissipation is calculated as follows:

$$P_{dis} = V_{DD} \times \{I_{DD} - \sum I_{OH}\} + \sum \{(V_{DD} - V_{OH}) \times I_{OH}\} + \sum (V_{OL} \times I_{OL})$$

2: Voltage spikes below V_{SS} at the $\overline{\text{MCLR}}$ /V_{PP} pin, inducing currents greater than 80 mA, may cause latchup. Thus, a series resistor of 50-100Ω should be used when applying a “low” level to the $\overline{\text{MCLR}}$ /V_{PP} pin, rather than pulling this pin directly to V_{SS}.

† NOTICE: Stresses above those listed under “Absolute Maximum Ratings” may cause permanent damage to the device. This is a stress rating only and functional operation of the device at those or any other conditions above those indicated in the operation listings of this specification is not implied. Exposure to maximum rating conditions for extended periods may affect device reliability.

PIC18F1220/1320

FIGURE 22-1: PIC18F1220/1320 VOLTAGE-FREQUENCY GRAPH (INDUSTRIAL)

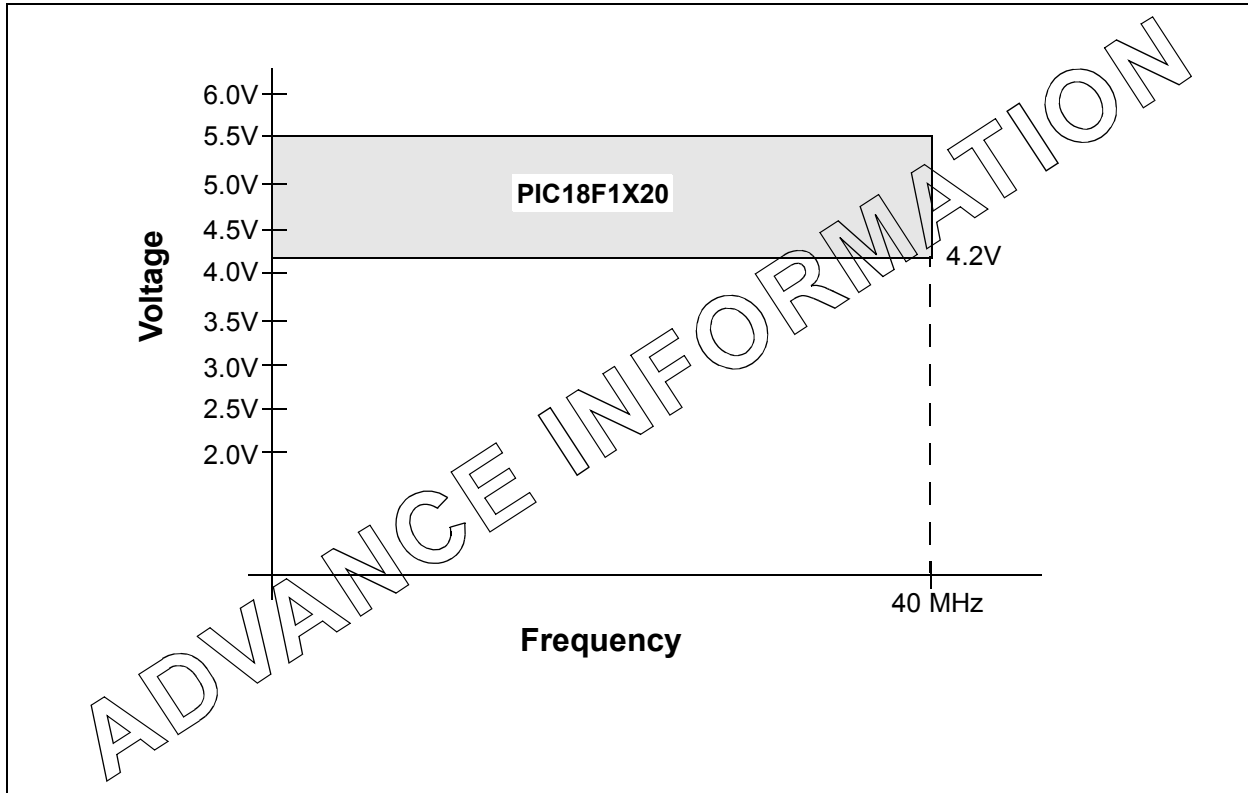
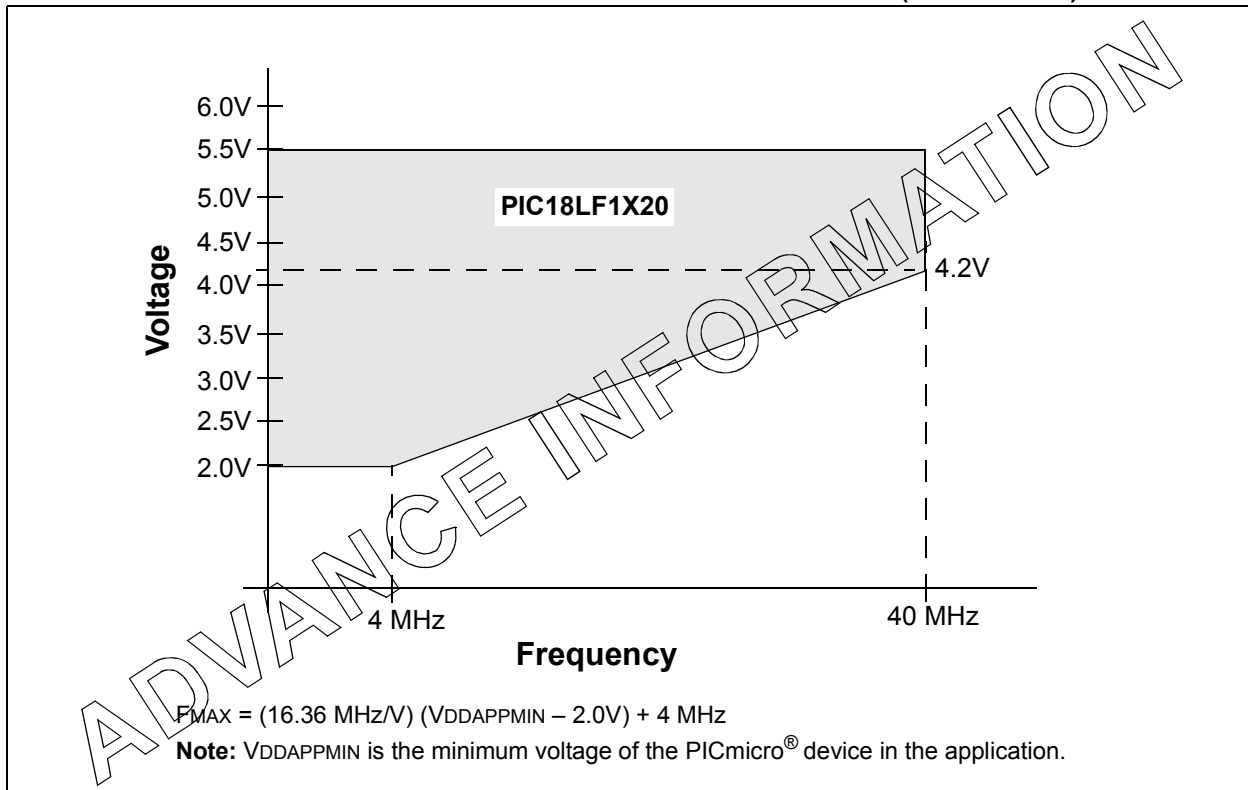

FIGURE 22-2: PIC18LF1220/1320 VOLTAGE-FREQUENCY GRAPH (INDUSTRIAL)



22.1 DC Characteristics: Supply Voltage

PIC18F1220/1320 (Industrial)

PIC18LF1220/1320 (Industrial)

PIC18LF1220/1320 (Industrial)		Standard Operating Conditions (unless otherwise stated)					
		Operating temperature $-40^{\circ}\text{C} \leq T_A \leq +85^{\circ}\text{C}$ for industrial					
PIC18F1220/1320 (Industrial, Extended)		Standard Operating Conditions (unless otherwise stated)					
		Operating temperature $-40^{\circ}\text{C} \leq T_A \leq +85^{\circ}\text{C}$ for industrial					
Param No.	Symbol	Characteristic	Min	Typ	Max	Units	Conditions
D001	VDD	Supply Voltage					
		PIC18LF1220/1320	2.0	—	5.5	V	HS, XT, RC and LP Osc mode
		PIC18F1220/1320	4.2	—	5.5	V	
D002	VDR	RAM Data Retention Voltage⁽¹⁾	1.5	—	—	V	
D003	VPOR	VDD Start Voltage to ensure internal Power-on Reset signal	—	—	0.7		See Section 4.1, "Power-on Reset (POR)" for details.
D004	SVDD	VDD Rise Rate to ensure internal Power-on Reset signal	0.05	—	—	V/ms	See Section 4.1, "Power-on Reset (POR)" for details.
D005	VBOR	Brown-out Reset Voltage					
		PIC18LF1220/1320					
		BORV1:BORV0 = 11	2.00	—	2.16	V	
		BORV1:BORV0 = 10	2.70	—	2.86	V	
		BORV1:BORV0 = 01	4.20	—	4.46	V	
D005		PIC18F1220/1320					
		BORV1:BORV0 = 1x	NA	—	NA	V	Not in operating voltage range of device
		BORV1:BORV0 = 01	4.20	—	4.46	V	
		BORV1:BORV0 = 00	4.50	—	4.78	V	

Legend: Shading of rows is to assist in readability of the table.

Note 1: This is the limit to which VDD can be lowered in SLEEP mode, or during a device RESET, without losing RAM data.

PIC18F1220/1320

22.2 DC Characteristics: Power-Down and Supply Current PIC18F1220/1320 (Industrial) PIC18LF1220/1320 (Industrial)

PIC18LF1220/1320 (Industrial)		Standard Operating Conditions (unless otherwise stated)				
		Operating temperature $-40^{\circ}\text{C} \leq T_A \leq +85^{\circ}\text{C}$ for industrial				
PIC18F1220/1320 (Industrial, Extended)		Standard Operating Conditions (unless otherwise stated)				
		Operating temperature $-40^{\circ}\text{C} \leq T_A \leq +85^{\circ}\text{C}$ for industrial				
Param No.	Device	Typ	Max	Units	Conditions	
Power-down Current (I_{PD})⁽¹⁾						
	PIC18LF1220/1320	0.1	TBD	μA	-40°C	$V_{DD} = 2.0\text{V}$, (SLEEP mode)
		0.1	TBD	μA	25°C	
		0.2	TBD	μA	85°C	
	PIC18LF1220/1320	0.1	TBD	μA	-40°C	$V_{DD} = 3.0\text{V}$, (SLEEP mode)
		0.1	TBD	μA	25°C	
		0.3	TBD	μA	85°C	
	All devices	0.1	TBD	μA	-40°C	$V_{DD} = 5.0\text{V}$, (SLEEP mode)
		0.1	TBD	μA	25°C	
		0.4	TBD	μA	85°C	

Legend: Shading of rows is to assist in readability of the table.

Note 1: The power-down current in SLEEP mode does not depend on the oscillator type. Power-down current is measured with the part in SLEEP mode, with all I/O pins in high-impedance state and tied to V_{DD} or V_{SS} , and all features that add delta current disabled (such as WDT, Timer1 Oscillator, BOR, etc.).

2: The supply current is mainly a function of operating voltage, frequency and mode. Other factors, such as I/O pin loading and switching rate, oscillator type and circuit, internal code execution pattern and temperature, also have an impact on the current consumption.

The test conditions for all I_{DD} measurements in active Operation mode are:

$OSC1$ = external square wave, from rail-to-rail; all I/O pins tri-stated, pulled to V_{DD} ;

$MCLR$ = V_{DD} ; WDT enabled/disabled as specified.

3: For RC oscillator configurations, current through R_{EXT} is not included. The current through the resistor can be estimated by the formula $I_r = V_{DD}/2R_{EXT}$ (mA) with R_{EXT} in $k\Omega$.

4: Standard low cost 32 kHz crystals have an operating temperature range of -10°C to $+70^{\circ}\text{C}$. Extended temperature crystals are available at a much higher cost.

22.2 DC Characteristics: Power-Down and Supply Current PIC18F1220/1320 (Industrial) PIC18LF1220/1320 (Industrial) (Continued)

PIC18LF1220/1320 (Industrial)		Standard Operating Conditions (unless otherwise stated) Operating temperature -40°C ≤ Ta ≤ +85°C for industrial						
PIC18F1220/1320 (Industrial, Extended)		Standard Operating Conditions (unless otherwise stated) Operating temperature -40°C ≤ Ta ≤ +85°C for industrial						
Param No.	Device	Typ	Max	Units	Conditions			
Supply Current (I_{DD})^(2,3)								
PIC18LF1220/1320		11	TBD	μA	-40°C	V _{DD} = 2.0V Fosc = 31 kHz (RC_RUN mode, Internal oscillator source)		
		13	TBD	μA	25°C			
		14	TBD	μA	85°C			
PIC18LF1220/1320		34	TBD	μA	-40°C		V _{DD} = 3.0V Fosc = 1 MHz (RC_RUN mode, Internal oscillator source)	
		28	TBD	μA	25°C			
		25	TBD	μA	85°C			
All devices		77	TBD	μA	-40°C			V _{DD} = 5.0V Fosc = 4 MHz (RC_RUN mode, Internal oscillator source)
		62	TBD	μA	25°C			
		53	TBD	μA	85°C			
PIC18LF1220/1320		100	TBD	μA	-40°C	V _{DD} = 2.0V Fosc = 1 MHz (RC_RUN mode, Internal oscillator source)		
		110	TBD	μA	25°C			
		120	TBD	μA	85°C			
PIC18LF1220/1320		180	TBD	μA	-40°C		V _{DD} = 3.0V Fosc = 4 MHz (RC_RUN mode, Internal oscillator source)	
		180	TBD	μA	25°C			
		170	TBD	μA	85°C			
All devices		340	TBD	μA	-40°C			V _{DD} = 5.0V Fosc = 1 MHz (RC_RUN mode, Internal oscillator source)
		330	TBD	μA	25°C			
		310	TBD	μA	85°C			
PIC18LF1220/1320		350	TBD	μA	-40°C	V _{DD} = 2.0V Fosc = 31 kHz (RC_RUN mode, Internal oscillator source)		
		360	TBD	μA	25°C			
		370	TBD	μA	85°C			
PIC18LF1220/1320		580	TBD	μA	-40°C		V _{DD} = 3.0V Fosc = 4 MHz (RC_RUN mode, Internal oscillator source)	
		580	TBD	μA	25°C			
		560	TBD	μA	85°C			
All devices		1.1	TBD	mA	-40°C			V _{DD} = 5.0V Fosc = 31 kHz (RC_RUN mode, Internal oscillator source)
		1.1	TBD	mA	25°C			
		1.0	TBD	mA	85°C			

Legend: Shading of rows is to assist in readability of the table.

- Note 1:** The power-down current in SLEEP mode does not depend on the oscillator type. Power-down current is measured with the part in SLEEP mode, with all I/O pins in high-impedance state and tied to V_{DD} or V_{SS}, and all features that add delta current disabled (such as WDT, Timer1 Oscillator, BOR, etc.).
- 2:** The supply current is mainly a function of operating voltage, frequency and mode. Other factors, such as I/O pin loading and switching rate, oscillator type and circuit, internal code execution pattern and temperature, also have an impact on the current consumption.
The test conditions for all I_{DD} measurements in active Operation mode are:
OSC1 = external square wave, from rail-to-rail; all I/O pins tri-stated, pulled to V_{DD};
MCLR = V_{DD}; WDT enabled/disabled as specified.
- 3:** For RC oscillator configurations, current through R_{EXT} is not included. The current through the resistor can be estimated by the formula $I_r = V_{DD}/2R_{EXT}$ (mA) with R_{EXT} in kΩ.
- 4:** Standard low cost 32 kHz crystals have an operating temperature range of -10°C to +70°C. Extended temperature crystals are available at a much higher cost.

PIC18F1220/1320

22.2 DC Characteristics: Power-Down and Supply Current PIC18F1220/1320 (Industrial) PIC18LF1220/1320 (Industrial) (Continued)

PIC18LF1220/1320 (Industrial)		Standard Operating Conditions (unless otherwise stated) Operating temperature $-40^{\circ}\text{C} \leq T_A \leq +85^{\circ}\text{C}$ for industrial					
PIC18F1220/1320 (Industrial, Extended)		Standard Operating Conditions (unless otherwise stated) Operating temperature $-40^{\circ}\text{C} \leq T_A \leq +85^{\circ}\text{C}$ for industrial					
Param No.	Device	Typ	Max	Units	Conditions		
Supply Current (I_{DD})^(2,3)							
PIC18LF1220/1320		4.7	TBD	μA	-40°C	$V_{DD} = 2.0\text{V}$ $V_{DD} = 3.0\text{V}$ $V_{DD} = 5.0\text{V}$ $V_{DD} = 2.0\text{V}$ $V_{DD} = 3.0\text{V}$ $V_{DD} = 5.0\text{V}$ $V_{DD} = 2.0\text{V}$ $V_{DD} = 3.0\text{V}$ $V_{DD} = 2.0\text{V}$ $V_{DD} = 3.0\text{V}$ $V_{DD} = 5.0\text{V}$	Fosc = 31 kHz (RC_IDLE mode, Internal oscillator source)
		4.6	TBD	μA	25°C		
		5.1	TBD	μA	85°C		
PIC18LF1220/1320		6.9	TBD	μA	-40°C		
		6.3	TBD	μA	25°C		
		6.8	TBD	μA	85°C		
All devices		12	TBD	μA	-40°C		
		10	TBD	μA	25°C		
		10	TBD	μA	85°C		
PIC18LF1220/1320		49	TBD	μA	-40°C	$V_{DD} = 2.0\text{V}$ $V_{DD} = 3.0\text{V}$ $V_{DD} = 5.0\text{V}$	Fosc = 1 MHz (RC_IDLE mode, Internal oscillator source)
		52	TBD	μA	25°C		
		56	TBD	μA	85°C		
PIC18LF1220/1320		73	TBD	μA	-40°C		
		77	TBD	μA	25°C		
		77	TBD	μA	85°C		
All devices		130	TBD	μA	-40°C		
		130	TBD	μA	25°C		
		130	TBD	μA	85°C		
PIC18LF1220/1320		140	TBD	μA	-40°C	$V_{DD} = 2.0\text{V}$ $V_{DD} = 3.0\text{V}$ $V_{DD} = 5.0\text{V}$	Fosc = 4 MHz (RC_IDLE mode, Internal oscillator source)
		140	TBD	μA	25°C		
		150	TBD	μA	85°C		
PIC18LF1220/1320		220	TBD	μA	-40°C		
		220	TBD	μA	25°C		
		210	TBD	μA	85°C		
All devices		390	TBD	μA	-40°C		
		400	TBD	μA	25°C		
		380	TBD	μA	85°C		

Legend: Shading of rows is to assist in readability of the table.

- Note 1:** The power-down current in SLEEP mode does not depend on the oscillator type. Power-down current is measured with the part in SLEEP mode, with all I/O pins in high-impedance state and tied to V_{DD} or V_{SS} , and all features that add delta current disabled (such as WDT, Timer1 Oscillator, BOR, etc.).
- 2:** The supply current is mainly a function of operating voltage, frequency and mode. Other factors, such as I/O pin loading and switching rate, oscillator type and circuit, internal code execution pattern and temperature, also have an impact on the current consumption.
The test conditions for all I_{DD} measurements in active Operation mode are:
 $OSC1$ = external square wave, from rail-to-rail; all I/O pins tri-stated, pulled to V_{DD} ;
 $MCLR$ = V_{DD} ; WDT enabled/disabled as specified.
- 3:** For RC oscillator configurations, current through R_{EXT} is not included. The current through the resistor can be estimated by the formula $I_r = V_{DD}/2R_{EXT}$ (mA) with R_{EXT} in $k\Omega$.
- 4:** Standard low cost 32 kHz crystals have an operating temperature range of -10°C to $+70^{\circ}\text{C}$. Extended temperature crystals are available at a much higher cost.

22.2 DC Characteristics: Power-Down and Supply Current PIC18F1220/1320 (Industrial) PIC18LF1220/1320 (Industrial) (Continued)

PIC18LF1220/1320 (Industrial)		Standard Operating Conditions (unless otherwise stated) Operating temperature -40°C ≤ TA ≤ +85°C for industrial						
PIC18F1220/1320 (Industrial, Extended)		Standard Operating Conditions (unless otherwise stated) Operating temperature -40°C ≤ TA ≤ +85°C for industrial						
Param No.	Device	Typ	Max	Units	Conditions			
Supply Current (I_{DD})^(2,3)								
	PIC18LF1220/1320	150	TBD	μA	-40°C	V _{DD} = 2.0V F _{OSC} = 1 MHz (PRI_RUN, EC oscillator)		
		150	TBD	μA	25°C			
		160	TBD	μA	85°C			
	PIC18LF1220/1320	340	TBD	μA	-40°C		V _{DD} = 3.0V F _{OSC} = 1 MHz (PRI_RUN, EC oscillator)	
		300	TBD	μA	25°C			
		280	TBD	μA	85°C			
All devices		720	TBD	μA	-40°C			V _{DD} = 5.0V F _{OSC} = 4 MHz (PRI_RUN, EC oscillator)
		630	TBD	μA	25°C			
		570	TBD	μA	85°C			
PIC18LF1220/1320		440	TBD	μA	-40°C	V _{DD} = 2.0V F _{OSC} = 4 MHz (PRI_RUN, EC oscillator)		
		450	TBD	μA	25°C			
		460	TBD	μA	85°C			
PIC18LF1220/1320		800	TBD	μA	-40°C		V _{DD} = 3.0V F _{OSC} = 4 MHz (PRI_RUN, EC oscillator)	
		780	TBD	μA	25°C			
		770	TBD	μA	85°C			
All devices		1.6	TBD	mA	-40°C			V _{DD} = 5.0V F _{OSC} = 40 MHz (PRI_RUN, EC oscillator)
		1.5	TBD	mA	25°C			
		1.5	TBD	mA	85°C			
All devices		9.5	TBD	mA	-40°C	V _{DD} = 4.2V F _{OSC} = 40 MHz (PRI_RUN, EC oscillator)		
		9.7	TBD	mA	25°C			
		9.9	TBD	mA	85°C			
All devices		11.9	TBD	mA	-40°C		V _{DD} = 5.0V F _{OSC} = 40 MHz (PRI_RUN, EC oscillator)	
		12.1	TBD	mA	25°C			
		12.3	TBD	mA	85°C			

Legend: Shading of rows is to assist in readability of the table.

Note 1: The power-down current in SLEEP mode does not depend on the oscillator type. Power-down current is measured with the part in SLEEP mode, with all I/O pins in high-impedance state and tied to V_{DD} or V_{SS}, and all features that add delta current disabled (such as WDT, Timer1 Oscillator, BOR, etc.).

2: The supply current is mainly a function of operating voltage, frequency and mode. Other factors, such as I/O pin loading and switching rate, oscillator type and circuit, internal code execution pattern and temperature, also have an impact on the current consumption.

The test conditions for all I_{DD} measurements in active Operation mode are:

OSC1 = external square wave, from rail-to-rail; all I/O pins tri-stated, pulled to V_{DD};

MCLR = V_{DD}; WDT enabled/disabled as specified.

3: For RC oscillator configurations, current through R_{EXT} is not included. The current through the resistor can be estimated by the formula $I_r = V_{DD}/2R_{EXT}$ (mA) with R_{EXT} in kΩ.

4: Standard low cost 32 kHz crystals have an operating temperature range of -10°C to +70°C. Extended temperature crystals are available at a much higher cost.

PIC18F1220/1320

22.2 DC Characteristics: Power-Down and Supply Current PIC18F1220/1320 (Industrial) PIC18LF1220/1320 (Industrial) (Continued)

PIC18LF1220/1320 (Industrial)		Standard Operating Conditions (unless otherwise stated) Operating temperature $-40^{\circ}\text{C} \leq T_A \leq +85^{\circ}\text{C}$ for industrial					
PIC18F1220/1320 (Industrial, Extended)		Standard Operating Conditions (unless otherwise stated) Operating temperature $-40^{\circ}\text{C} \leq T_A \leq +85^{\circ}\text{C}$ for industrial					
Param No.	Device	Typ	Max	Units	Conditions		
Supply Current (I_{DD})^(2,3)							
	PIC18LF1220/1320	37	TBD	μA	-40°C	V _{DD} = 2.0V	Fosc = 1 MHz (PRI_IDLE mode, EC oscillator)
		37	TBD	μA	25°C		
		38	TBD	μA	85°C		
	PIC18LF1220/1320	58	TBD	μA	-40°C	V _{DD} = 3.0V	
		59	TBD	μA	25°C		
		60	TBD	μA	85°C		
	All devices	110	TBD	μA	-40°C	V _{DD} = 5.0V	
		110	TBD	μA	25°C		
		110	TBD	μA	85°C		
	PIC18LF1220/1320	140	TBD	μA	-40°C	V _{DD} = 2.0V	Fosc = 4 MHz (PRI_IDLE mode, EC oscillator)
		140	TBD	μA	25°C		
		140	TBD	μA	85°C		
	PIC18LF1220/1320	220	TBD	μA	-40°C	V _{DD} = 3.0V	
		230	TBD	μA	25°C		
		230	TBD	μA	85°C		
	All devices	410	TBD	μA	-40°C	V _{DD} = 5.0V	
		420	TBD	μA	25°C		
		430	TBD	μA	85°C		
	All devices	3.1	TBD	mA	-40°C	V _{DD} = 4.2 V	Fosc = 40 MHz (PRI_IDLE mode, EC oscillator)
		3.2	TBD	mA	25°C		
		3.3	TBD	mA	85°C		
	All devices	4.4	TBD	mA	-40°C	V _{DD} = 5.0V	
		4.6	TBD	mA	25°C		
		4.6	TBD	mA	85°C		

Legend: Shading of rows is to assist in readability of the table.

Note 1: The power-down current in SLEEP mode does not depend on the oscillator type. Power-down current is measured with the part in SLEEP mode, with all I/O pins in high-impedance state and tied to V_{DD} or V_{SS}, and all features that add delta current disabled (such as WDT, Timer1 Oscillator, BOR, etc.).

2: The supply current is mainly a function of operating voltage, frequency and mode. Other factors, such as I/O pin loading and switching rate, oscillator type and circuit, internal code execution pattern and temperature, also have an impact on the current consumption.

The test conditions for all I_{DD} measurements in active Operation mode are:

OSC1 = external square wave, from rail-to-rail; all I/O pins tri-stated, pulled to V_{DD};

MCLR = V_{DD}; WDT enabled/disabled as specified.

3: For RC oscillator configurations, current through R_{EXT} is not included. The current through the resistor can be estimated by the formula $I_r = V_{DD}/2R_{EXT}$ (mA) with R_{EXT} in k Ω .

4: Standard low cost 32 kHz crystals have an operating temperature range of -10°C to $+70^{\circ}\text{C}$. Extended temperature crystals are available at a much higher cost.

22.2 DC Characteristics: Power-Down and Supply Current PIC18F1220/1320 (Industrial) PIC18LF1220/1320 (Industrial) (Continued)

PIC18LF1220/1320 (Industrial)		Standard Operating Conditions (unless otherwise stated) Operating temperature -40°C ≤ Ta ≤ +85°C for industrial					
PIC18F1220/1320 (Industrial, Extended)		Standard Operating Conditions (unless otherwise stated) Operating temperature -40°C ≤ Ta ≤ +85°C for industrial					
Param No.	Device	Typ	Max	Units	Conditions		
Supply Current (I_{DD})^(2,3)							
PIC18LF1220/1320		13	TBD	μA	-10°C	V _{DD} = 2.0V	F _{OSC} = 32 kHz ⁽⁴⁾ (SEC_RUN mode, Timer1 as clock)
		14	TBD	μA	25°C		
		16	TBD	μA	70°C		
PIC18LF1220/1320		34	TBD	μA	-10°C	V _{DD} = 3.0V	
		31	TBD	μA	25°C		
		28	TBD	μA	70°C		
All devices		72	TBD	μA	-10°C	V _{DD} = 5.0V	
		65	TBD	μA	25°C		
		59	TBD	μA	70°C		
Supply Current (I_{DD})^(2,3)							
PIC18LF1220/1320		5.5	TBD	μA	-10°C	V _{DD} = 2.0V	F _{OSC} = 32 kHz ⁽⁴⁾ (SEC_IDLE mode, Timer1 as clock)
		5.8	TBD	μA	25°C		
		6.1	TBD	μA	70°C		
PIC18LF1220/1320		8.2	TBD	μA	-10°C	V _{DD} = 3.0V	
		8.6	TBD	μA	25°C		
		8.8	TBD	μA	70°C		
All devices		43	TBD	μA	-10°C	V _{DD} = 5.0V	
		13	TBD	μA	25°C		
		43	TBD	μA	70°C		

Legend: Shading of rows is to assist in readability of the table.

Note 1: The power-down current in SLEEP mode does not depend on the oscillator type. Power-down current is measured with the part in SLEEP mode, with all I/O pins in high-impedance state and tied to V_{DD} or V_{SS}, and all features that add delta current disabled (such as WDT, Timer1 Oscillator, BOR, etc.).

2: The supply current is mainly a function of operating voltage, frequency and mode. Other factors, such as I/O pin loading and switching rate, oscillator type and circuit, internal code execution pattern and temperature, also have an impact on the current consumption.

The test conditions for all I_{DD} measurements in active Operation mode are:

OSC1 = external square wave, from rail-to-rail; all I/O pins tri-stated, pulled to V_{DD};

MCLR = V_{DD}; WDT enabled/disabled as specified.

3: For RC oscillator configurations, current through R_{EXT} is not included. The current through the resistor can be estimated by the formula $I_r = V_{DD}/2R_{EXT}$ (mA) with R_{EXT} in kΩ.

4: Standard low cost 32 kHz crystals have an operating temperature range of -10°C to +70°C. Extended temperature crystals are available at a much higher cost.

PIC18F1220/1320

22.2 DC Characteristics: Power-Down and Supply Current PIC18F1220/1320 (Industrial) PIC18LF1220/1320 (Industrial) (Continued)

PIC18LF1220/1320 (Industrial)		Standard Operating Conditions (unless otherwise stated) Operating temperature $-40^{\circ}\text{C} \leq T_A \leq +85^{\circ}\text{C}$ for industrial					
PIC18F1220/1320 (Industrial, Extended)		Standard Operating Conditions (unless otherwise stated) Operating temperature $-40^{\circ}\text{C} \leq T_A \leq +85^{\circ}\text{C}$ for industrial					
Param No.	Device	Typ	Max	Units	Conditions		
D022 (ΔI_{WDT})	Watchdog Timer	1.7	TBD	μA	-40°C	$V_{DD} = 2.0\text{V}$	
		2.1	TBD	μA	25°C		
		2.6	TBD	μA	85°C		
		2.2	TBD	μA	-40°C	$V_{DD} = 3.0\text{V}$	
		2.4	TBD	μA	25°C		
		2.8	TBD	μA	85°C		
		2.9	TBD	μA	-40°C	$V_{DD} = 5.0\text{V}$	
		3.1	TBD	μA	25°C		
		3.3	TBD	μA	85°C		
D022A (ΔI_{BOR})	Brown-out Reset	17	TBD	μA	-40°C to $+85^{\circ}\text{C}$	$V_{DD} = 3.0\text{V}$	
		47	TBD	μA	-40°C to $+85^{\circ}\text{C}$	$V_{DD} = 5.0\text{V}$	
D022B (ΔI_{LVD})	Low Voltage Detect	14	TBD	μA	-40°C to $+85^{\circ}\text{C}$	$V_{DD} = 2.0\text{V}$	
		18	TBD	μA	-40°C to $+85^{\circ}\text{C}$	$V_{DD} = 3.0\text{V}$	
		21	TBD	μA	-40°C to $+85^{\circ}\text{C}$	$V_{DD} = 5.0\text{V}$	
D025 (ΔI_{OSCB})	Timer1 Oscillator	1.0	TBD	μA	-10°C	$V_{DD} = 2.0\text{V}$	32 kHz on Timer1 ⁽⁴⁾
		1.1	TBD	μA	25°C		
		1.1	TBD	μA	70°C		
		1.2	TBD	μA	-10°C	$V_{DD} = 3.0\text{V}$	32 kHz on Timer1 ⁽⁴⁾
		1.3	TBD	μA	25°C		
		1.2	TBD	μA	70°C		
		1.8	TBD	μA	-10°C	$V_{DD} = 5.0\text{V}$	32 kHz on Timer1 ⁽⁴⁾
		1.9	TBD	μA	25°C		
1.9	TBD	μA	70°C				
D026 (ΔI_{AD})	A/D Converter	1.0	TBD	μA		$V_{DD} = 2.0\text{V}$	A/D on, not converting
		1.0	TBD	μA		$V_{DD} = 3.0\text{V}$	
		1.0	TBD	μA		$V_{DD} = 5.0\text{V}$	

Legend: Shading of rows is to assist in readability of the table.

Note 1: The power-down current in SLEEP mode does not depend on the oscillator type. Power-down current is measured with the part in SLEEP mode, with all I/O pins in high-impedance state and tied to V_{DD} or V_{SS} , and all features that add delta current disabled (such as WDT, Timer1 Oscillator, BOR, etc.).

2: The supply current is mainly a function of operating voltage, frequency and mode. Other factors, such as I/O pin loading and switching rate, oscillator type and circuit, internal code execution pattern and temperature, also have an impact on the current consumption.

The test conditions for all I_{DD} measurements in active Operation mode are:

$OSC1$ = external square wave, from rail-to-rail; all I/O pins tri-stated, pulled to V_{DD} ;

$MCLR$ = V_{DD} ; WDT enabled/disabled as specified.

3: For RC oscillator configurations, current through R_{EXT} is not included. The current through the resistor can be estimated by the formula $I_r = V_{DD}/2R_{EXT}$ (mA) with R_{EXT} in $k\Omega$.

4: Standard low cost 32 kHz crystals have an operating temperature range of -10°C to $+70^{\circ}\text{C}$. Extended temperature crystals are available at a much higher cost.

22.3 DC Characteristics: PIC18F1220/1320 (Industrial) PIC18LF1220/1320 (Industrial)

DC CHARACTERISTICS			Standard Operating Conditions (unless otherwise stated) Operating temperature $-40^{\circ}\text{C} \leq T_A \leq +85^{\circ}\text{C}$ for industrial			
Param No.	Symbol	Characteristic	Min	Max	Units	Conditions
D030 D030A D031 D032 D032A D033	V _{IL}	Input Low Voltage I/O ports: with TTL buffer with Schmitt Trigger buffer RC3 and RC4 MCLR OSC1 (in XT, HS and LP modes) and T1OSI OSC1 (in RC and EC mode) ⁽¹⁾	V _{SS} — V _{SS} V _{SS} V _{SS} V _{SS}	0.15 V _{DD} 0.8 0.2 V _{DD} 0.3 V _{DD} 0.2 V _{DD} 0.3 V _{DD} 0.2 V _{DD}	V V V V V V V	V _{DD} < 4.5V 4.5V ≤ V _{DD} ≤ 5.5V
D040 D040A D041 D042 D042A D043	V _{IH}	Input High Voltage I/O ports: with TTL buffer with Schmitt Trigger buffer RC3 and RC4 MCLR, OSC1 (EC mode) OSC1 (in XT, HS and LP modes) and T1OSI OSC1 (RC mode) ⁽¹⁾	0.25 V _{DD} + 0.8V 2.0 0.8 V _{DD} 0.7 V _{DD} 0.8 V _{DD} 0.7 V _{DD} 0.9 V _{DD}	V _{DD} V _{DD} V _{DD} V _{DD} V _{DD} V _{DD} V _{DD}	V V V V V V V	V _{DD} < 4.5V 4.5V ≤ V _{DD} ≤ 5.5V
D060 D061 D063	I _{IL}	Input Leakage Current ^(2,3) I/O ports MCLR OSC1	— — —	±1 ±5 ±5	μA μA μA	V _{SS} ≤ V _{PIN} ≤ V _{DD} , Pin at hi-impedance V _{SS} ≤ V _{PIN} ≤ V _{DD} V _{SS} ≤ V _{PIN} ≤ V _{DD}
D070	I _{PU} I _{PURB}	Weak Pull-up Current PORTB weak pull-up current	50	400	μA	V _{DD} = 5V, V _{PIN} = V _{SS}

Note 1: In RC oscillator configuration, the OSC1/CLKI pin is a Schmitt Trigger input. It is not recommended that the PICmicro device be driven with an external clock while in RC mode.

2: The leakage current on the MCLR pin is strongly dependent on the applied voltage level. The specified levels represent normal operating conditions. Higher leakage current may be measured at different input voltages.

3: Negative current is defined as current sourced by the pin.

4: Parameter is characterized but not tested.

PIC18F1220/1320

22.3 DC Characteristics: PIC18F1220/1320 (Industrial) PIC18LF1220/1320 (Industrial) (Continued)

DC CHARACTERISTICS			Standard Operating Conditions (unless otherwise stated) Operating temperature $-40^{\circ}\text{C} \leq T_A \leq +85^{\circ}\text{C}$ for industrial			
Param No.	Symbol	Characteristic	Min	Max	Units	Conditions
D080	VOL	Output Low Voltage I/O ports	—	0.6	V	$I_{OL} = 8.5\text{ mA}$, $V_{DD} = 4.5\text{V}$, -40°C to $+85^{\circ}\text{C}$
D083		OSC2/CLKO (RC mode)	—	0.6	V	$I_{OL} = 1.6\text{ mA}$, $V_{DD} = 4.5\text{V}$, -40°C to $+85^{\circ}\text{C}$
D090	VOH	Output High Voltage ⁽³⁾ I/O ports	$V_{DD} - 0.7$	—	V	$I_{OH} = -3.0\text{ mA}$, $V_{DD} = 4.5\text{V}$, -40°C to $+85^{\circ}\text{C}$
D092		OSC2/CLKO (RC mode)	$V_{DD} - 0.7$	—	V	$I_{OH} = -1.3\text{ mA}$, $V_{DD} = 4.5\text{V}$, -40°C to $+85^{\circ}\text{C}$
D150	VOD	Open Drain High Voltage	—	8.5	V	RA4 pin
Capacitive Loading Specs on Output Pins						
D100 ⁽⁴⁾	Cosc2	OSC2 pin	—	15	pF	In XT, HS and LP modes when external clock is used to drive OSC1
D101	Cio	All I/O pins and OSC2 (in RC mode)	—	50	pF	To meet the AC Timing Specifications
D102	CB	SCL, SDA	—	400	pF	In I ² C mode

Note 1: In RC oscillator configuration, the OSC1/CLKI pin is a Schmitt Trigger input. It is not recommended that the PICmicro device be driven with an external clock while in RC mode.

2: The leakage current on the MCLR pin is strongly dependent on the applied voltage level. The specified levels represent normal operating conditions. Higher leakage current may be measured at different input voltages.

3: Negative current is defined as current sourced by the pin.

4: Parameter is characterized but not tested.

TABLE 22-1: MEMORY PROGRAMMING REQUIREMENTS

DC Characteristics			Standard Operating Conditions (unless otherwise stated) Operating temperature $-40^{\circ}\text{C} \leq T_A \leq +85^{\circ}\text{C}$ for industrial				
Param No.	Sym	Characteristic	Min	Typ†	Max	Units	Conditions
Internal Program Memory Programming Specifications⁽¹⁾							
D110	V _{PP}	Voltage on $\overline{\text{MCLR}}/\text{VPP}$ pin	9.00	—	13.25	V	(Note 2)
D112	I _{PP}	Current into $\overline{\text{MCLR}}/\text{VPP}$ pin	—	—	5	μA	
D113	I _{DDP}	Supply current during programming	—	—	10	mA	
Data EEPROM Memory							
D120	ED	Byte Endurance	100K	1M	—	E/W	-40°C to +85°C
D121	V _{DRW}	V _{DD} for read/write	V _{MIN}	—	5.5	V	Using EECON to read/write V _{MIN} = Minimum operating voltage
D122	T _{DEW}	Erase/Write cycle time	—	4	—	ms	
D123	T _{RETD}	Characteristic Retention	40	—	—	Year	Provided no other specifications are violated
D124	T _{REF}	Number of total erase/write cycles before refresh ⁽³⁾	1M	10M	—	E/W	-40°C to +85°C
Program FLASH Memory							
D130	EP	Cell Endurance	10K	100K	—	E/W	-40°C to +85°C
D131	V _{PR}	V _{DD} for read	V _{MIN}	—	5.5	V	V _{MIN} = Minimum operating voltage
D132	V _{IE}	V _{DD} for Block Erase	4.5	—	5.5	V	Using ICSP port
D132A	V _{IW}	V _{DD} for externally timed erase or write	4.5	—	5.5	V	Using ICSP port
D132B	V _{PEW}	V _{DD} for self-timed write	V _{MIN}	—	5.5	V	V _{MIN} = Minimum operating voltage
D133	T _{IE}	ICSP Block Erase cycle time	—	4	—	ms	V _{DD} > 4.5V
D133A	T _{IW}	ICSP Erase or Write cycle time (externally timed)	1	—	—	ms	V _{DD} > 4.5V
D133A	T _{IW}	Self-timed Write cycle time	—	2	—	ms	
D134	T _{RETD}	Characteristic Retention	40	—	—	Year	Provided no other specifications are violated

† Data in "Typ" column is at 5.0V, 25°C unless otherwise stated. These parameters are for design guidance only and are not tested.

Note 1: These specifications are for programming the on-chip program memory through the use of Table Write instructions.

2: The pin may be kept in this range at times other than programming, but it is not recommended.

3: Refer to Section 7.8 for a more detailed discussion on data EEPROM endurance.

PIC18F1220/1320

FIGURE 22-1: LOW VOLTAGE DETECT CHARACTERISTICS

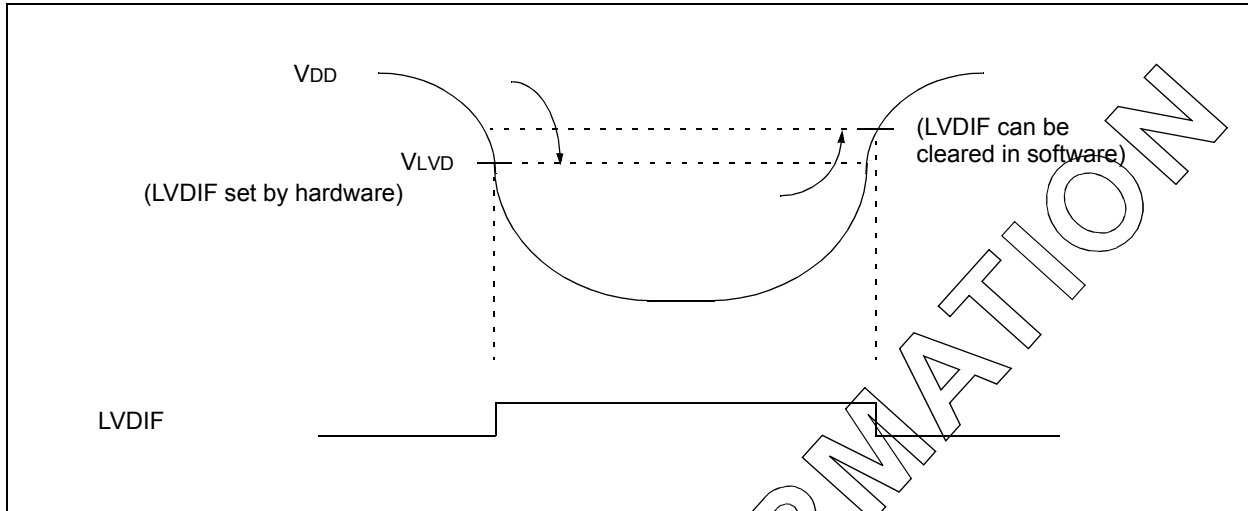

TABLE 22-2: LOW VOLTAGE DETECT CHARACTERISTICS

		Standard Operating Conditions (unless otherwise stated) Operating temperature $-40^{\circ}\text{C} \leq T_A \leq +85^{\circ}\text{C}$ for industrial						
Param No.	Symbol	Characteristic	Min	Typ†	Max	Units	Conditions	
D420		LVD Voltage on VDD transition high to low	LVV = 0000	1.80	1.86	1.91	V	
			LVV = 0001	2.00	2.06	2.12	V	
			LVV = 0010	2.20	2.27	2.34	V	
			LVV = 0011	2.40	2.47	2.55	V	
			LVV = 0100	2.50	2.58	2.66	V	
			LVV = 0101	2.70	2.78	2.86	V	
			LVV = 0110	2.80	2.89	2.98	V	
			LVV = 0111	3.00	3.10	3.20	V	
			LVV = 1000	3.30	3.41	3.52	V	
			LVV = 1001	3.50	3.61	3.72	V	
			LVV = 1010	3.60	3.72	3.84	V	
			LVV = 1011	3.80	3.92	4.04	V	
			LVV = 1100	4.00	4.13	4.26	V	
			LVV = 1101	4.20	4.33	4.46	V	
LVV = 1110	4.50	4.64	4.78	V				

† Production tested at $T_{AMB} = 25^{\circ}\text{C}$. Specifications over temp. limits ensured by characterization.

22.4 AC (Timing) Characteristics

22.4.1 TIMING PARAMETER SYMBOLOGY

The timing parameter symbols have been created following one of the following formats:

1. TppS2ppS
2. TppS
3. TCC:ST (I²C specifications only)
4. Ts (I²C specifications only)

<p>T</p> <p>F Frequency</p>	<p>T Time</p>
----------------------------------	--------------------

Lowercase letters (pp) and their meanings:

<p>pp</p> <p>cc CCP1</p> <p>ck CLKO</p> <p>cs \overline{CS}</p> <p>di SDI</p> <p>do SDO</p> <p>dt Data in</p> <p>io I/O port</p> <p>mc \overline{MCLR}</p>	<p>osc OSC1</p> <p>rd \overline{RD}</p> <p>rw \overline{RD} or \overline{WR}</p> <p>sc SCK</p> <p>ss \overline{SS}</p> <p>t0 T0CKI</p> <p>t1 T1CKI</p> <p>wr \overline{WR}</p>
--	---

Uppercase letters and their meanings:

<p>S</p> <p>F Fall</p> <p>H High</p> <p>I Invalid (Hi-Impedance)</p> <p>L Low</p> <p>I²C only</p> <p>AA output access</p> <p>BUF Bus free</p>	<p>P Period</p> <p>R Rise</p> <p>V Valid</p> <p>Z Hi-Impedance</p> <p>High High</p> <p>Low Low</p>
--	---

TCC:ST (I²C specifications only)

<p>CC</p> <p>HD Hold</p> <p>ST</p> <p>DAT DATA input hold</p> <p>STA START condition</p>	<p>SU Setup</p> <p>STO STOP condition</p>
---	--

PIC18F1220/1320

22.4.2 TIMING CONDITIONS

The temperature and voltages specified in Table 22-3 apply to all timing specifications unless otherwise noted. Figure 22-2 specifies the load conditions for the timing specifications.

TABLE 22-3: TEMPERATURE AND VOLTAGE SPECIFICATIONS - AC

AC CHARACTERISTICS	Standard Operating Conditions (unless otherwise stated)
	Operating temperature $-40^{\circ}\text{C} \leq T_A \leq +85^{\circ}\text{C}$ for industrial
	Operating voltage V_{DD} range as described in DC spec Section 22.1 and Section 22.3.
	LC parts operate for industrial temperatures only.

FIGURE 22-2: LOAD CONDITIONS FOR DEVICE TIMING SPECIFICATIONS

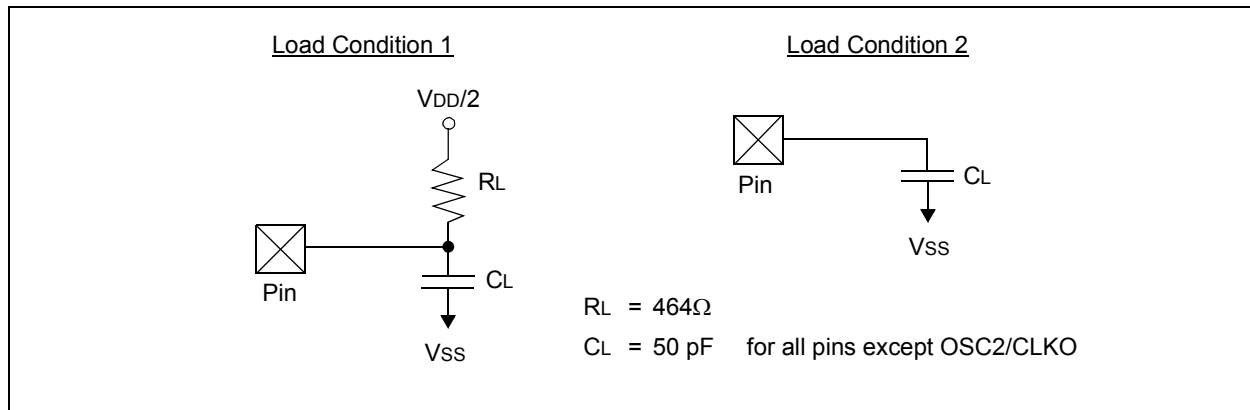

22.4.3 TIMING DIAGRAMS AND SPECIFICATIONS

FIGURE 22-3: EXTERNAL CLOCK TIMING (ALL MODES EXCEPT PLL)

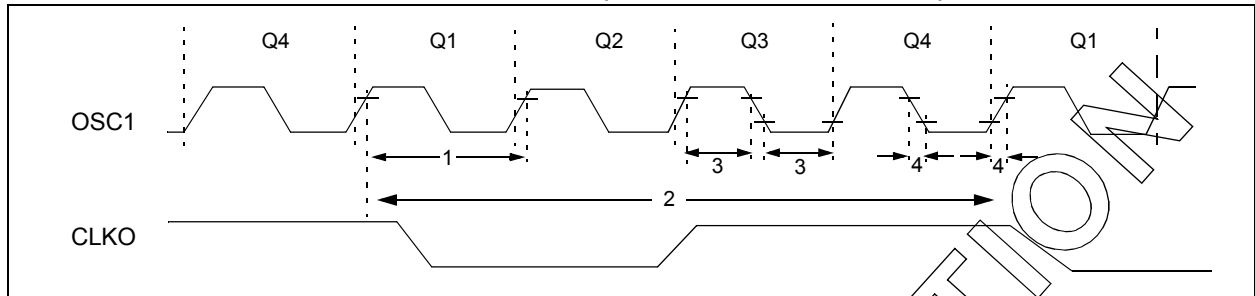

TABLE 22-4: EXTERNAL CLOCK TIMING REQUIREMENTS

Param. No.	Symbol	Characteristic	Min	Max	Units	Conditions
1A	Fosc	External CLKI Frequency ⁽¹⁾ Oscillator Frequency ⁽¹⁾	DC	40	MHz	EC, ECIO
			DC	4	MHz	RC osc
			0.1	4	MHz	XT osc
			4	25	MHz	HS osc
			4	10	MHz	HS + PLL osc
			5	200	kHz	LP osc mode
1	Tosc	External CLKI Period ⁽¹⁾ Oscillator Period ⁽¹⁾	25	—	ns	EC, ECIO
			250	—	ns	RC osc
			250	10,000	ns	XT osc
			25	250	ns	HS osc
			100	250	ns	HS + PLL osc
			5	—	μs	LP osc
2	Tcy	Instruction Cycle Time ⁽¹⁾	100	—	ns	Tcy = 4/Fosc
3	TosL, TosH	External Clock in (OSC1) High or Low Time	30	—	ns	XT osc
			2.5	—	μs	LP osc
			10	—	ns	HS osc
4	TosR, TosF	External Clock in (OSC1) Rise or Fall Time	—	20	ns	XT osc
			—	50	ns	LP osc
			—	7.5	ns	HS osc

Note 1: Instruction cycle period (Tcy) equals four times the input oscillator time-base period for all configurations except PLL. All specified values are based on characterization data for that particular oscillator type under standard operating conditions, with the device executing code. Exceeding these specified limits may result in an unstable oscillator operation and/or higher than expected current consumption. All devices are tested to operate at “min.” values with an external clock applied to the OSC1/CLKI pin. When an external clock input is used, the “max.” cycle time limit is “DC” (no clock) for all devices.

PIC18F1220/1320

TABLE 22-5: PLL CLOCK TIMING SPECIFICATIONS (V_{DD} = 4.2 TO 5.5V)

Param No.	Sym	Characteristic	Min	Typ†	Max	Units	Conditions
F10	FOSC	Oscillator Frequency Range	4	—	10	MHz	HS mode only
F11	F _{SYS}	On-Chip VCO System Frequency	16	—	40	MHz	HS mode only
F12	t _{RC}	PLL Start-up Time (Lock Time)	—	—	2	ms	
F13	ΔCLK	CLKO Stability (Jitter)	-2	—	+2	%	

† Data in "Typ" column is at 5V, 25°C unless otherwise stated. These parameters are for design guidance only and are not tested.

22.5 DC Characteristics: Internal RC Accuracy PIC18F1220/1320 (Industrial) PIC18LF1220/1320 (Industrial)

Param No.	Device	Min	Typ	Max	Units	Conditions	
PIC18LF1220/1320 (Industrial)		Standard Operating Conditions (unless otherwise stated) Operating temperature -40°C ≤ T _A ≤ +85°C for industrial					
PIC18F1220/1320 (Industrial)		Standard Operating Conditions (unless otherwise stated) Operating temperature -40°C ≤ T _A ≤ +85°C for industrial					
INTOSC Accuracy @ Freq = 8 MHz, 4 MHz, 2 MHz, 1 MHz, 500 kHz, 250 kHz, 125 kHz⁽¹⁾							
F1	PIC18LF1220/1320	TBD	+/-1	TBD	%	25°C	V _{DD} = 2.0V
F2		TBD	+/-1	TBD	%	25°C	V _{DD} = 3.0V
F3	All devices	TBD	+/-1	TBD	%	25°C	V _{DD} = 5.0V
INTRC Accuracy @ Freq = 31.25 kHz⁽²⁾							
F4	PIC18LF1220/1320	28.125	—	34.375	kHz	25°C	V _{DD} = 2.0V
F5		28.125	—	34.375	kHz	25°C	V _{DD} = 3.0V
F6	All devices	28.125	—	34.375	kHz	25°C	V _{DD} = 5.0V
INTRC Stability⁽³⁾							
F7	PIC18F1220/1320	TBD	1	TBD	%	25°C	V _{DD} = 2.0V
F8		TBD	1	TBD	%	25°C	V _{DD} = 3.0V
F9	All devices	TBD	1	TBD	%	25°C	V _{DD} = 5.0V

Legend: Shading of rows is to assist in readability of the table.

Note 1: Frequency calibrated at 25°C. OSC_{TUNE} register can be used to compensate for temperature drift.

Note 2: INTRC frequency after calibration.

Note 3: Change of INTRC frequency as V_{DD} changes.

FIGURE 22-4: CLKO AND I/O TIMING

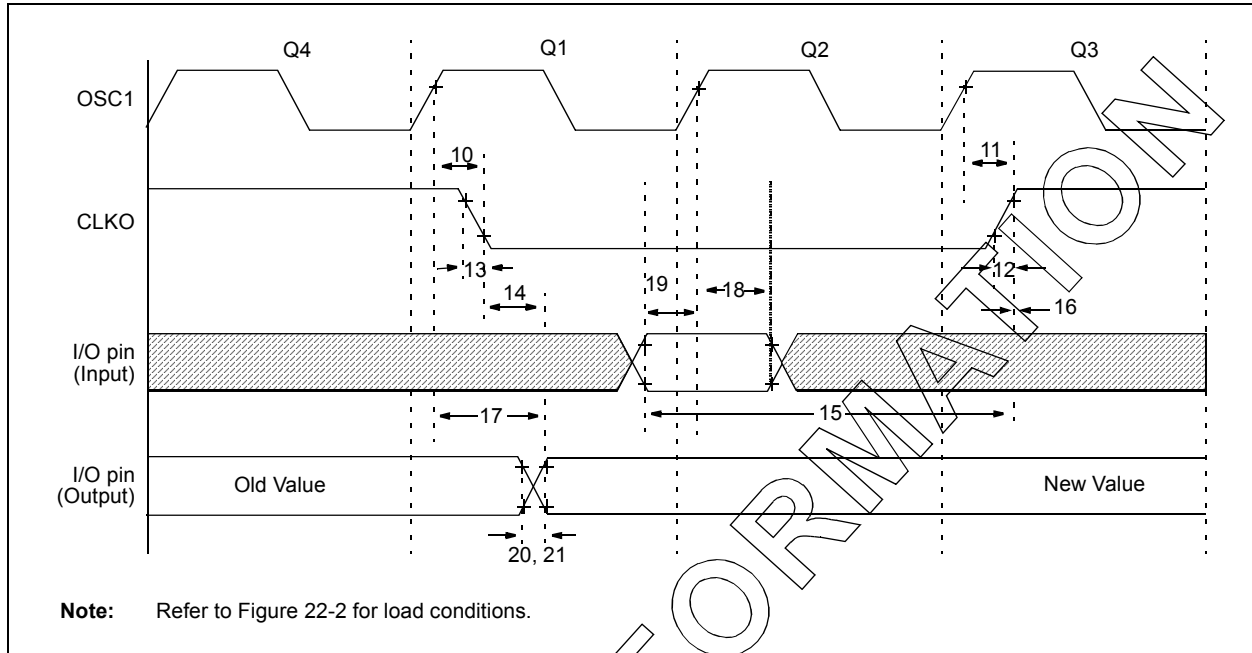

TABLE 22-6: CLKO AND I/O TIMING REQUIREMENTS

Param. No.	Symbol	Characteristic	Min	Typ	Max	Units	Conditions
10	TosH2ckL	OSC1↑ to CLKO↓	—	75	200	ns	(1)
11	TosH2ckH	OSC1↑ to CLKO↑	—	75	200	ns	(1)
12	TckR	CLKO rise time	—	35	100	ns	(1)
13	TckF	CLKO fall time	—	35	100	ns	(1)
14	TckL2ioV	CLKO↓ to Port out valid	—	—	0.5 Tcy + 20	ns	(1)
15	TioV2ckH	Port in valid before CLKO↑	0.25 Tcy + 25	—	—	ns	(1)
16	TckH2ioI	Port in hold after CLKO↑	0	—	—	ns	(1)
17	TosH2ioV	OSC1↑ (Q1 cycle) to Port out valid	—	50	150	ns	
18	TosH2ioI	OSC1↑ (Q2 cycle) to Port input invalid (I/O in hold time)	PIC18FXX20 100	—	—	ns	
18A			PIC18LFXX20 200	—	—	ns	
19	TioV2psH	Port input valid to OSC1↑ (I/O in setup time)	0	—	—	ns	
20	TioR	Port output rise time	PIC18FXX20 —	10	25	ns	
20A			PIC18LFXX20 —	—	60	ns	
21	TioF	Port output fall time	PIC18FXX20 —	10	25	ns	
21A			PIC18LFXX20 —	—	60	ns	
22††	TINP	INT pin high or low time	Tcy	—	—	ns	
23††	TRBP	RB7:RB4 change INT high or low time	Tcy	—	—	ns	
24††	TRCP	RC7:RC4 change INT high or low time	20	—	—	ns	

†† These parameters are asynchronous events not related to any internal clock edges.

Note 1: Measurements are taken in RC mode, where CLKO output is 4 x Tosc.

PIC18F1220/1320

FIGURE 22-5: RESET, WATCHDOG TIMER, OSCILLATOR START-UP TIMER AND POWER-UP TIMER TIMING

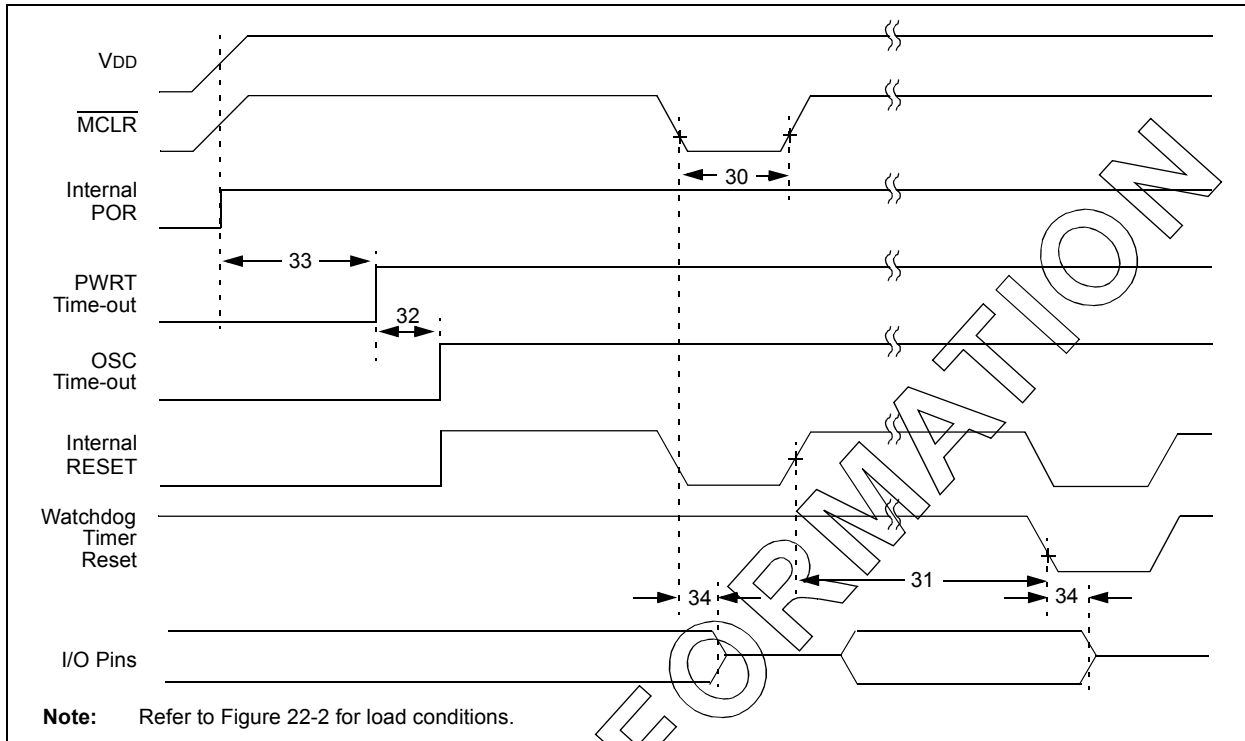

FIGURE 22-6: BROWN-OUT RESET TIMING

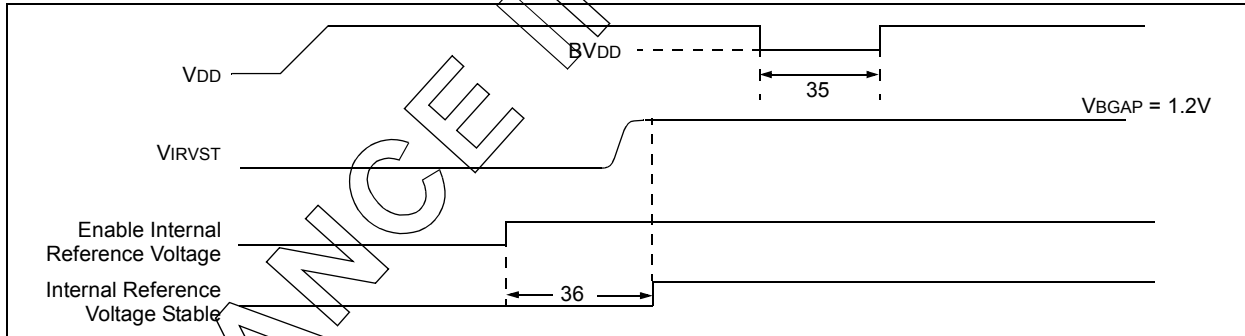
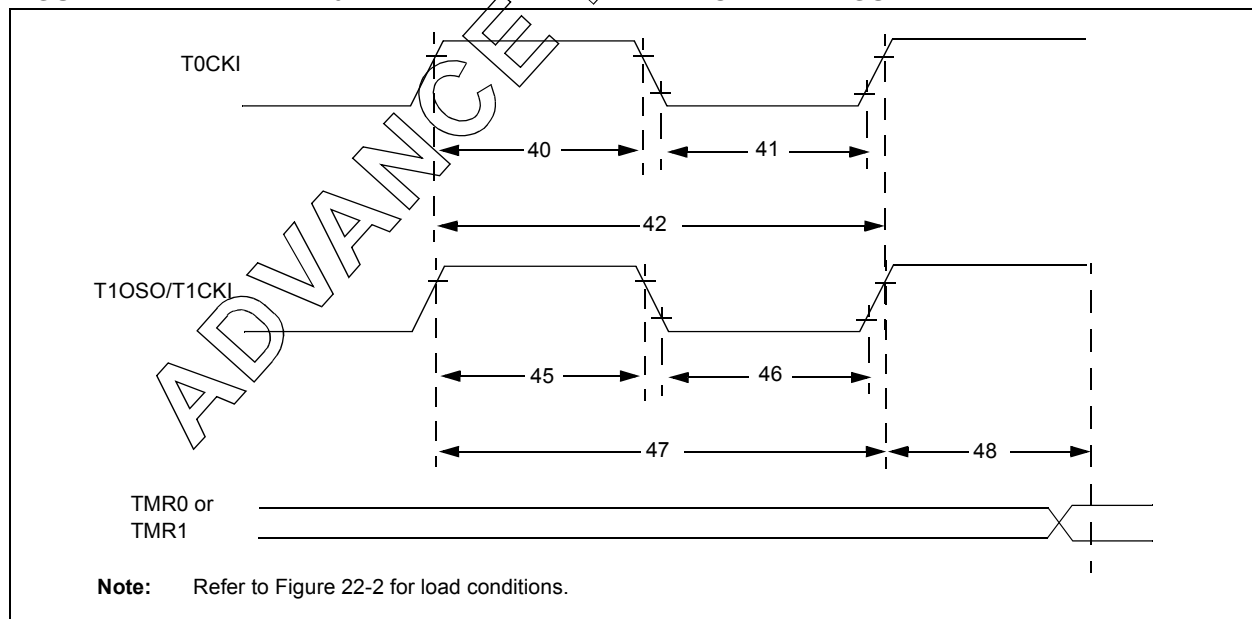

TABLE 22-7: RESET, WATCHDOG TIMER, OSCILLATOR START-UP TIMER, POWER-UP TIMER AND BROWN-OUT RESET REQUIREMENTS

Param. No.	Symbol	Characteristic	Min	Typ	Max	Units	Conditions
30	Tmcl	MCLR Pulse Width (low)	2	—	—	μs	
31	TWDT	Watchdog Timer Time-out Period (No Postscaler)	—	4.0	TBD	ms	
32	TOST	Oscillation Start-up Timer Period	1024 T _{osc}	—	1024 T _{osc}	—	T _{osc} = OSC1 period
33	TPWRT	Power up Timer Period	—	65.5	132	ms	
34	T _{ioz}	I/O Hi-Impedance from MCLR Low or Watchdog Timer Reset	—	2	—	μs	
35	TBOR	Brown-out Reset Pulse Width	200	—	—	μs	V _{DD} ≤ B _{VDD} (see D005)
36	TIVRST	Time for Internal Reference Voltage to become stable	—	20	50	μs	
37	TLVD	Low Voltage Detect Pulse Width	200	—	—	μs	V _{DD} ≤ V _{LVD}

FIGURE 22-7: TIMER0 AND TIMER1 EXTERNAL CLOCK TIMINGS



PIC18F1220/1320

TABLE 22-8: TIMER0 AND TIMER1 EXTERNAL CLOCK REQUIREMENTS

Param No.	Symbol	Characteristic		Min	Max	Units	Conditions	
40	Tt0H	T0CKI High Pulse Width	No Prescaler	$0.5 T_{CY} + 20$	—	ns		
			With Prescaler	10	—	ns		
41	Tt0L	T0CKI Low Pulse Width	No Prescaler	$0.5 T_{CY} + 20$	—	ns		
			With Prescaler	10	—	ns		
42	Tt0P	T0CKI Period	No Prescaler	$T_{CY} + 10$	—	ns		
			With Prescaler	Greater of: $20 \text{ ns or } \frac{T_{CY} + 40}{N}$	—	ns		N = prescale value (1, 2, 4, ..., 256)
45	Tt1H	T1CKI High Time	Synchronous, no prescaler	$0.5 T_{CY} + 20$	—	ns		
			Synchronous, with prescaler	PIC18FXX20	10	—		ns
				PIC18LFXX20	25	—		ns
			Asynchronous	PIC18FXX20	30	—		ns
PIC18LFXX20	50	—		ns				
46	Tt1L	T1CKI Low Time	Synchronous, no prescaler	$0.5 T_{CY} + 5$	—	ns		
			Synchronous, with prescaler	PIC18FXX20	10	—		ns
				PIC18LFXX20	25	—		ns
			Asynchronous	PIC18FXX20	30	—		ns
PIC18LFXX20	TBD	TBD		ns				
47	Tt1P	T1CKI Input Period	Synchronous	Greater of: $20 \text{ ns or } \frac{T_{CY} + 40}{N}$	—	ns	N = prescale value (1, 2, 4, 8)	
			Asynchronous	60	—	ns		
	Ft1	T1CKI Oscillator Input Frequency Range		DC	50	kHz		
48	Tcke2tmrl	Delay from External T1CKI Clock Edge to Timer Increment		$2 T_{OSC}$	$7 T_{OSC}$	—		

ADVANCE

FIGURE 22-8: CAPTURE/COMPARE/PWM TIMINGS (ALL CCP MODULES)

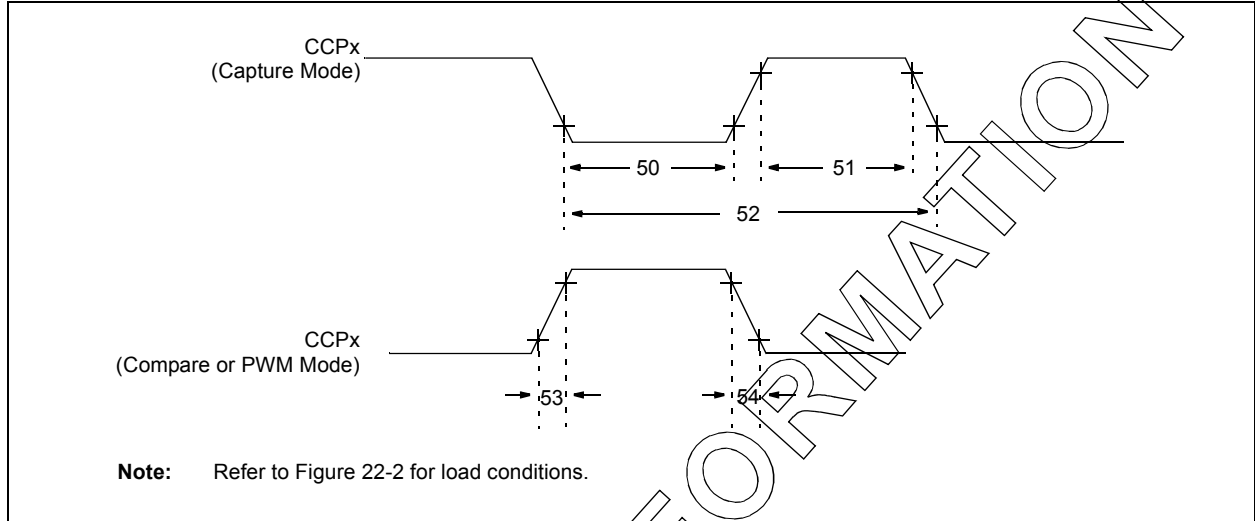

TABLE 22-9: CAPTURE/COMPARE/PWM REQUIREMENTS (ALL CCP MODULES)

Param. No.	Symbol	Characteristic		Min	Max	Units	Conditions	
50	TccL	CCPx input low time	No Prescaler	$0.5 T_{CY} + 20$	—	ns		
			With Prescaler	PIC18FXX20	10	—		ns
				PIC18LFXX20	20	—		ns
51	TccH	CCPx input high time	No Prescaler	$0.5 T_{CY} + 20$	—	ns		
			With Prescaler	PIC18FXX20	10	—		ns
				PIC18LFXX20	20	—		ns
52	TccP	CCPx input period		$\frac{3 T_{CY} + 40}{N}$	—	ns	N = prescale value (1,4 or 16)	
53	TccR	CCPx output fall time	PIC18FXX20	—	25	ns		
			PIC18LFXX20	—	45	ns		
54	TccF	CCPx output fall time	PIC18FXX20	—	25	ns		
			PIC18LFXX20	—	45	ns		

PIC18F1220/1320

FIGURE 22-9: USART SYNCHRONOUS TRANSMISSION (MASTER/SLAVE) TIMING

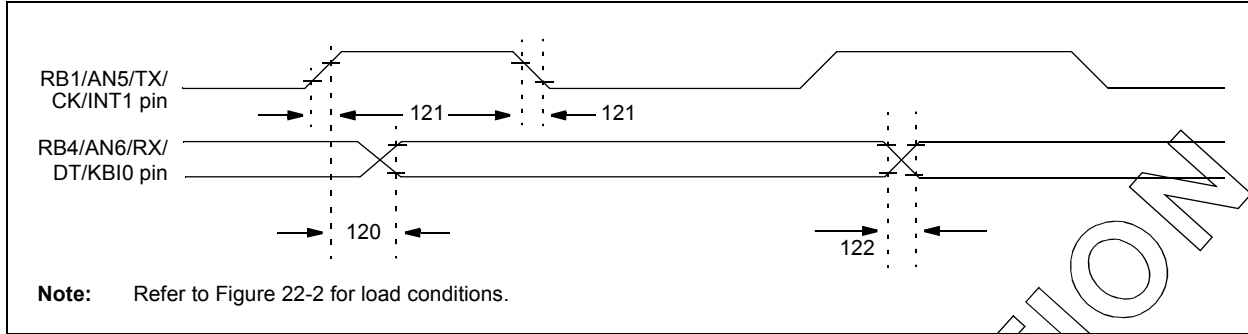

TABLE 22-10: USART SYNCHRONOUS TRANSMISSION REQUIREMENTS

Param. No.	Symbol	Characteristic	Min	Max	Units	Conditions
120	TckH2dtV	SYNC XMIT (MASTER & SLAVE)				
		Clock high to data out valid	PIC18FXX20	40	ns	
			PIC18LFXX20	100	ns	
121	Tckrf	Clock out rise time and fall time (Master mode)	PIC18FXX20	20	ns	
			PIC18LFXX20	50	ns	
122	TdtV	Data out rise time and fall time	PIC18FXX20	20	ns	
			PIC18LFXX20	50	ns	

FIGURE 22-10: USART SYNCHRONOUS RECEIVE (MASTER/SLAVE) TIMING

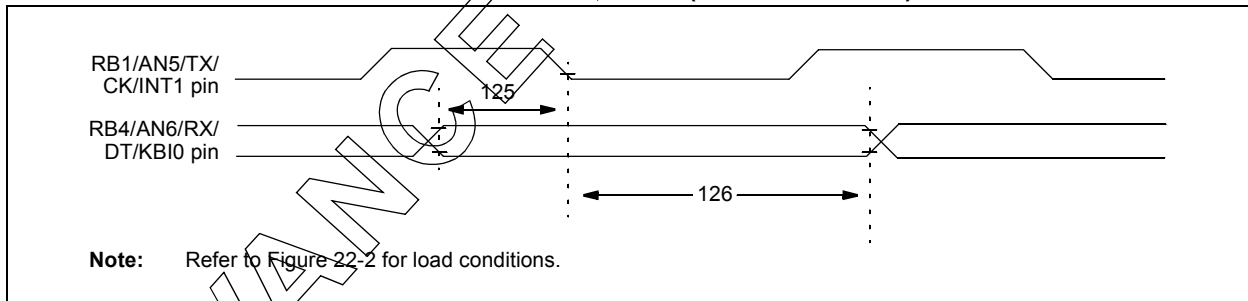

TABLE 22-11: USART SYNCHRONOUS RECEIVE REQUIREMENTS

Param. No.	Symbol	Characteristic	Min	Max	Units	Conditions
125	TdtV2ckl	SYNC RCV (MASTER & SLAVE)				
		Data hold before CK↓ (DT hold time)	10	—	ns	
126	TckL2dtl	Data hold after CK↓ (DT hold time)	15	—	ns	

PIC18F1220/1320

**TABLE 22-12: A/D CONVERTER CHARACTERISTICS: PIC18F1220/1320 (INDUSTRIAL)
PIC18LF1220/1320 (INDUSTRIAL)**

Param No.	Symbol	Characteristic	Min	Typ	Max	Units	Conditions	
A01	NR	Resolution	—	—	10	bit	$\Delta V_{REF} \geq 3.0V$	
A03	EIL	Integral linearity error	—	—	$< \pm 1$	LSb	$\Delta V_{REF} \geq 3.0V$	
A04	EDL	Differential linearity error	—	—	$< \pm 1$	LSb	$\Delta V_{REF} \geq 3.0V$	
A06	EOFF	Offset error	—	—	± 1	LSb	$\Delta V_{REF} \geq 3.0V$	
A07	EGN	Gain error	—	—	$< \pm 1$	LSb	$\Delta V_{REF} \geq 3.0V$	
A10	—	Monotonicity	guaranteed ⁽²⁾			—		
A20	ΔV_{REF}	Reference voltage range (VREFH - VREFL)	3	—	$AV_{DD} - AV_{SS}$	V	For 10-bit resolution	
A21	VREFH	Reference voltage High	$AV_{SS} + 3.0V$	—	$AV_{DD} + 0.3V$	V	For 10-bit resolution	
A22	VREFL	Reference voltage Low	$AV_{SS} - 0.3V$	—	$AV_{DD} - 3.0V$	V	For 10-bit resolution	
A25	VAIN	Analog input voltage	VREFL	—	VREFH	V		
A28	AVDD	Analog supply voltage	$V_{DD} - 0.3$	—	$V_{DD} + 0.3$	V		
A29	AVSS	Analog supply voltage	$V_{SS} - 0.3$	—	$V_{SS} + 0.3$	V		
A30	ZAIN	Recommended impedance of analog voltage source	—	—	2.5	k Ω		
A40	IAD	A/D conversion current (VDD)	PIC18FXX20	—	180	—	μA	Average current consumption when A/D is on (Note 1)
		PIC18LFXX20	—	90	—	μA		
A50	IREF	VREF input current (Note 3)	—	—	± 5	μA	During VAIN acquisition. During A/D conversion cycle.	
			—	—	± 150	μA		

- Note 1:** When A/D is off, it will not consume any current other than minor leakage current. The power-down current spec includes any such leakage from the A/D module.
- 2:** The A/D conversion result never decreases with an increase in the input voltage, and has no missing codes.
- 3:** VREFH current is from RA3/AN3/VREF+ pin or AVDD, whichever is selected as the VREFH source. VREFL current is from RA2/AN2/VREF- pin or AVSS, whichever is selected as the VREFL source.

PIC18F1220/1320

FIGURE 22-11: A/D CONVERSION TIMING

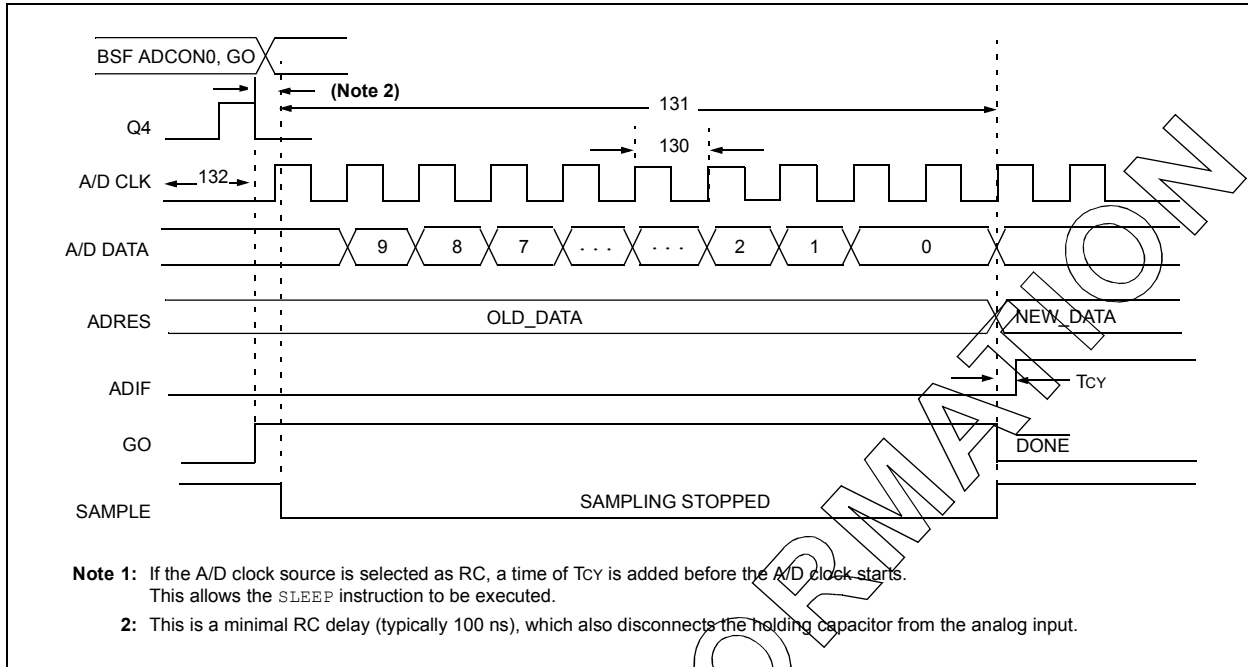

TABLE 22-13: A/D CONVERSION REQUIREMENTS

Param No.	Symbol	Characteristic	Min	Max	Units	Conditions	
130	TAD	A/D Clock Period	PIC18FXX20	1.6	20 ⁽⁵⁾	μs	TOSC based, $V_{REF} \geq 3.0\text{V}$
			PIC18LFXX20	3.0	20 ⁽⁵⁾	μs	TOSC based, V_{REF} full range
		A/D RC mode	PIC18FXX20	2.0	6.0	μs	
			PIC18LFXX20	3.0	9.0	μs	
131	T _{CV}	Conversion Time (not including acquisition time) (Note 1)	11	12	TAD		
132	T _{ACQ}	Acquisition Time (Note 3)	15	—	μs	$-40^{\circ}\text{C} \leq \text{Temp} \leq +125^{\circ}\text{C}$	
			10	—	μs	$0^{\circ}\text{C} \leq \text{Temp} \leq +125^{\circ}\text{C}$	
135	T _{SWC}	Switching Time from convert → sample	—	(Note 4)			
136	T _{AMP}	Amplifier Settling Time (Note 2)	1	—	μs	This may be used if the “new” input voltage has not changed by more than 1 LSb (i.e., 5 mV @ 5.12V) from the last sampled voltage (as stated on CHOLD).	

- Note 1:** ADRES register may be read on the following T_{CY} cycle.
- Note 2:** See Section 17.0 for minimum conditions, when input voltage has changed more than 1 LSb.
- Note 3:** The time for the holding capacitor to acquire the “New” input voltage, when the voltage changes full scale after the conversion (AV_{DD} to AV_{SS} , or AV_{SS} to AV_{DD}). The source impedance (R_S) on the input channels is 50Ω .
- Note 4:** On the next Q4 cycle of the device clock.
- Note 5:** The time of the A/D clock period is dependent on the device frequency and the TAD clock divider.

23.0 PRELIMINARY DC AND AC CHARACTERISTICS GRAPHS AND TABLES

Note: The graphs and tables provided following this note are a statistical summary based on a limited number of samples and are provided for informational purposes only. The performance characteristics listed herein are not tested or guaranteed. In some graphs or tables, the data presented may be outside the specified operating range (e.g., outside specified power supply range) and therefore, outside the warranted range.

“Typical” represents the mean of the distribution at 25°C. “Maximum” or “minimum” represents (mean + 3σ) or (mean - 3σ) respectively, where σ is a standard deviation, over the whole temperature range.

FIGURE 23-1: TYPICAL I_{DD} vs. F_{osc} OVER V_{DD} (EC MODE)

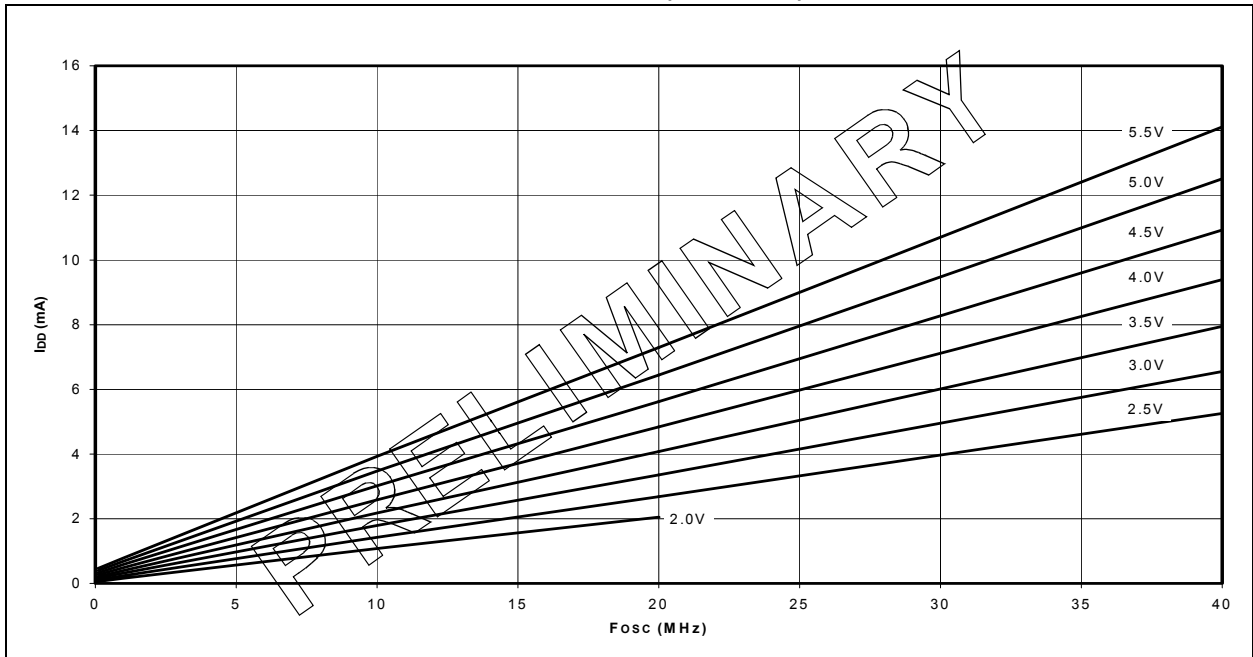

FIGURE 23-2: TYPICAL TOTAL I_{PD} vs. V_{DD} (SLEEP MODE, WDT ENABLED)



PIC18F1220/1320

FIGURE 23-3: TYPICAL I_{PD} vs. V_{DD} (SLEEP MODE, ALL PERIPHERALS DISABLED)

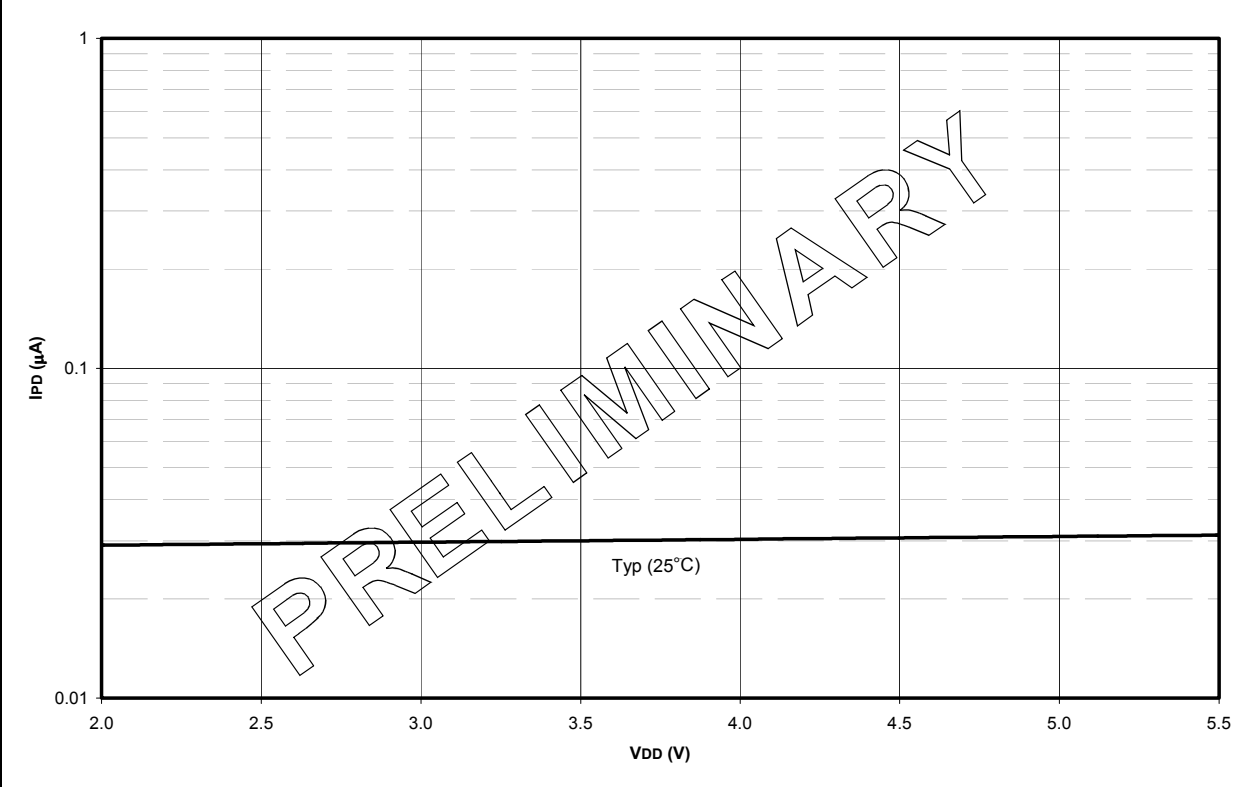
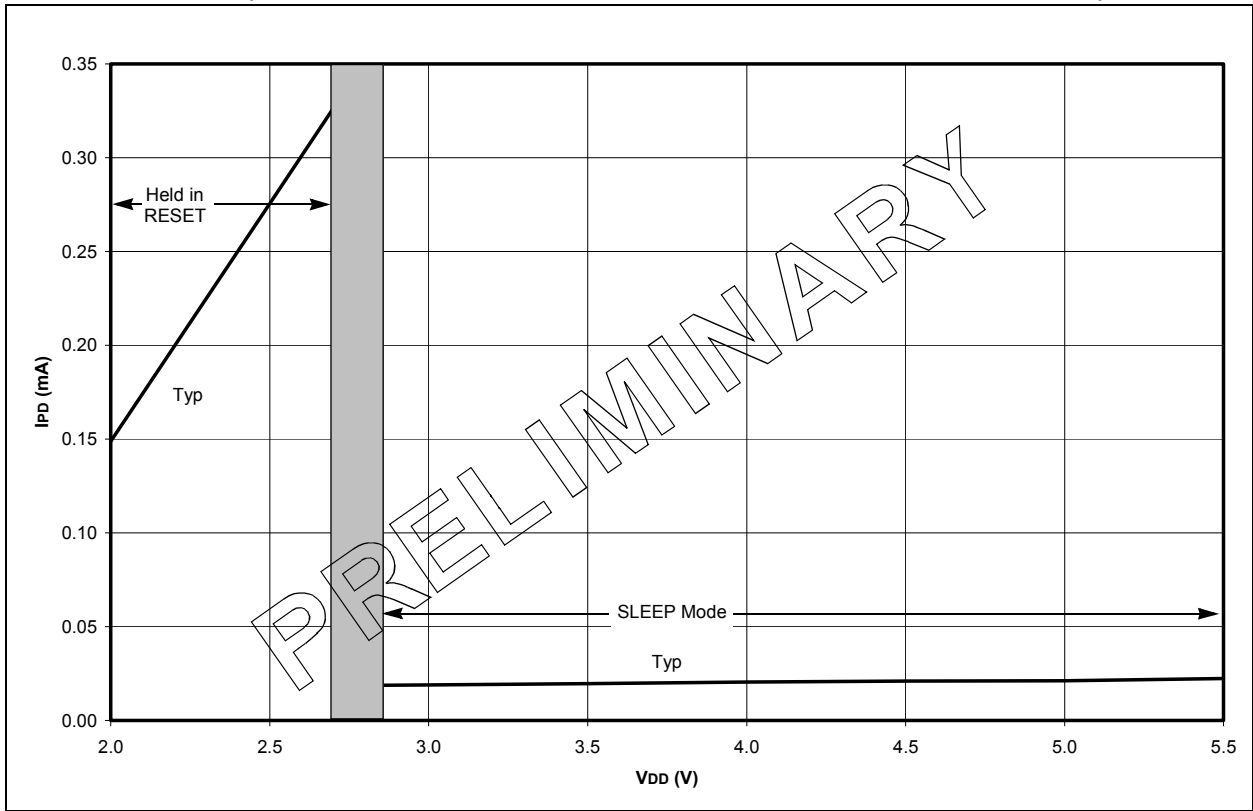

FIGURE 23-4: TYPICAL TOTAL I_{DD} vs. V_{DD} OVER TEMPERATURE
(-40°C TO +85°C, INTOSC AT 2 MHz, BOR ENABLED AT 2.70 - 2.86V)



PIC18F1220/1320

FIGURE 23-5: TYPICAL TOTAL IPD vs. VDD (-10°C TO +70°C, SLEEP MODE, TIMER1 OSCILLATOR ENABLED)

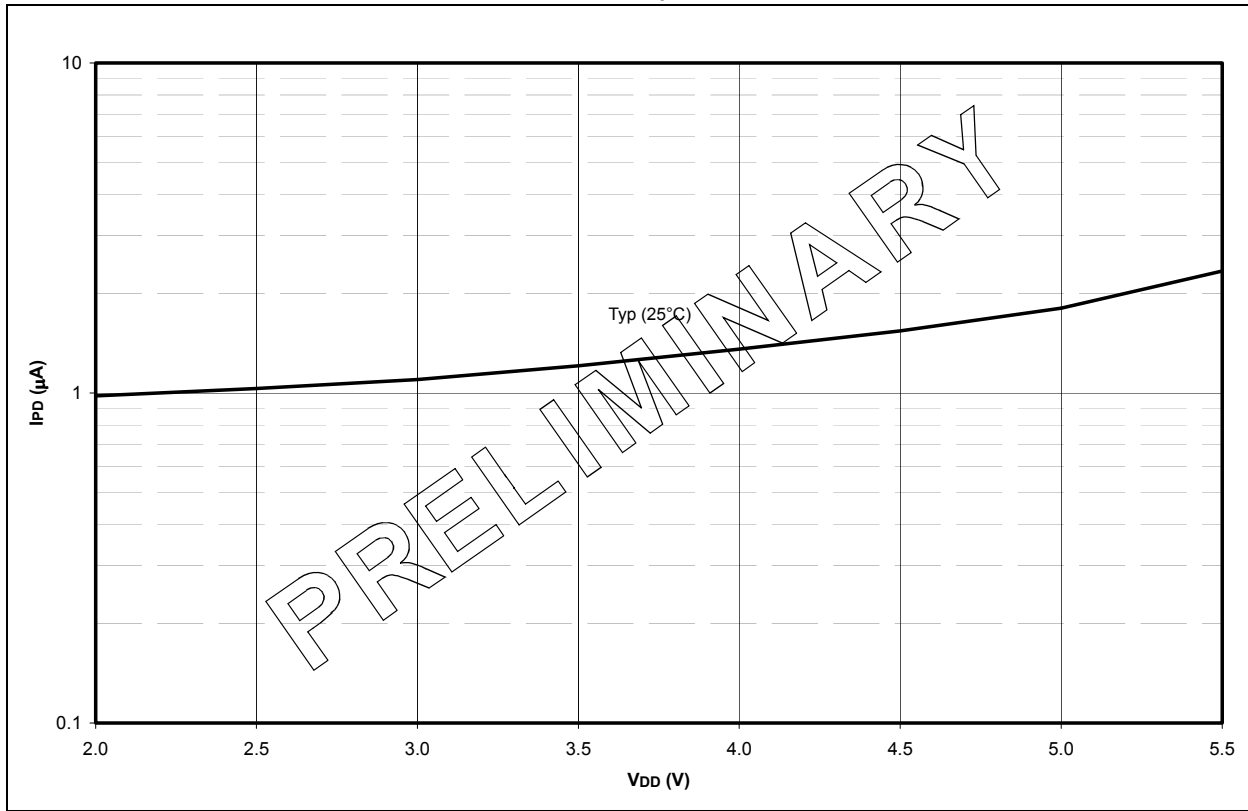
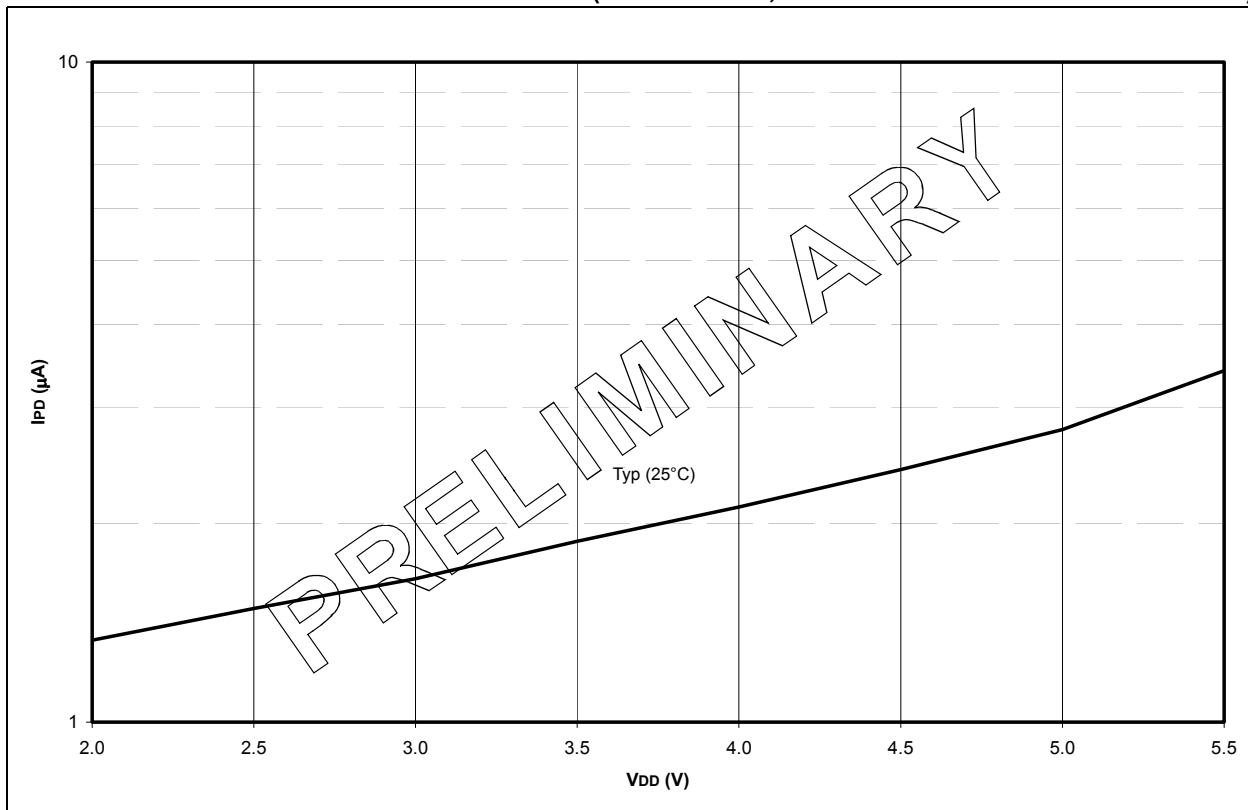

FIGURE 23-6: TYPICAL TOTAL IPD vs. VDD (SLEEP MODE, TIMER1 AND OSCILLATOR ENABLED)



24.0 PACKAGING INFORMATION

24.1 Package Marking Information

18-Lead PDIP

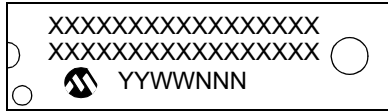

Example

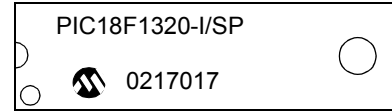

18-Lead SOIC

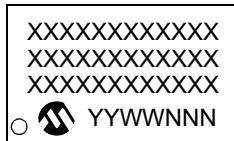

Example



20-Lead SSOP

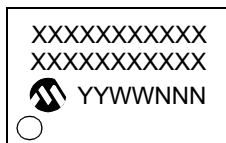

Example



28-Lead QFN

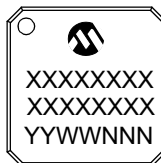

Example

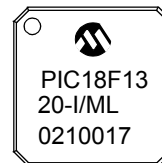

Legend:	XX...X	Customer specific information*
	Y	Year code (last digit of calendar year)
	YY	Year code (last 2 digits of calendar year)
	WW	Week code (week of January 1 is week '01')
	NNN	Alphanumeric traceability code
Note: In the event the full Microchip part number cannot be marked on one line, it will be carried over to the next line thus limiting the number of available characters for customer specific information.		

* Standard PICmicro device marking consists of Microchip part number, year code, week code, and traceability code. For PICmicro device marking beyond this, certain price adders apply. Please check with your Microchip Sales Office. For QTP devices, any special marking adders are included in QTP price.

PIC18F1220/1320

24.2 Package Details

The following sections give the technical details of the packages.

18-Lead Plastic Dual In-line (P) – 300 mil (PDIP)

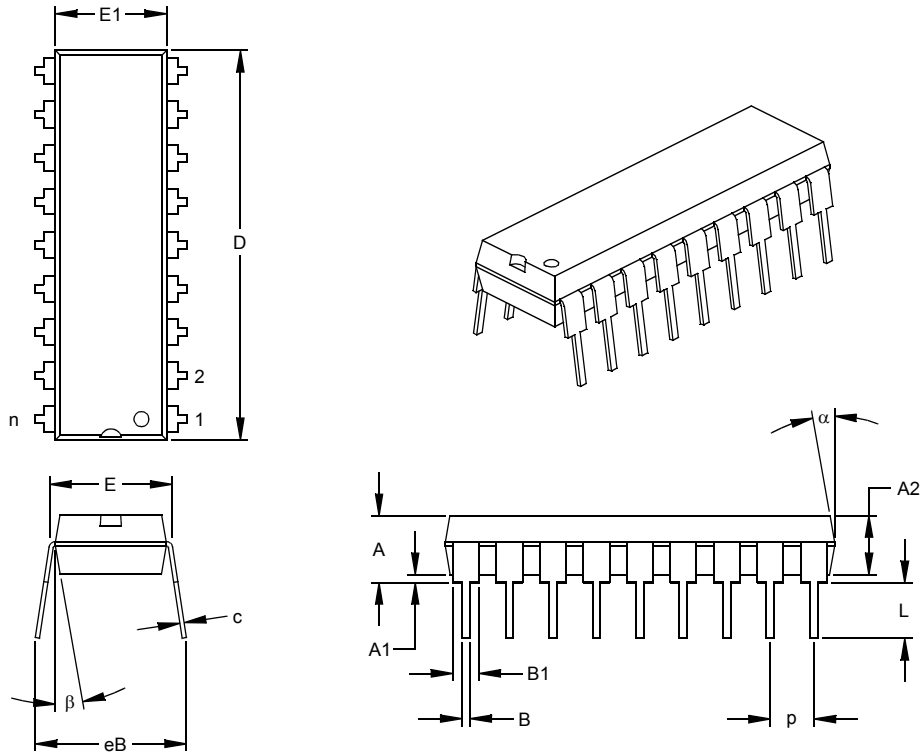

Dimension	Units	INCHES*			MILLIMETERS		
		MIN	NOM	MAX	MIN	NOM	MAX
Number of Pins	n		18			18	
Pitch	p		.100			2.54	
Top to Seating Plane	A	.140	.155	.170	3.56	3.94	4.32
Molded Package Thickness	A2	.115	.130	.145	2.92	3.30	3.68
Base to Seating Plane	A1	.015			0.38		
Shoulder to Shoulder Width	E	.300	.313	.325	7.62	7.94	8.26
Molded Package Width	E1	.240	.250	.260	6.10	6.35	6.60
Overall Length	D	.890	.898	.905	22.61	22.80	22.99
Tip to Seating Plane	L	.125	.130	.135	3.18	3.30	3.43
Lead Thickness	c	.008	.012	.015	0.20	0.29	0.38
Upper Lead Width	B1	.045	.058	.070	1.14	1.46	1.78
Lower Lead Width	B	.014	.018	.022	0.36	0.46	0.56
Overall Row Spacing	§ eB	.310	.370	.430	7.87	9.40	10.92
Mold Draft Angle Top	α	5	10	15	5	10	15
Mold Draft Angle Bottom	β	5	10	15	5	10	15

* Controlling Parameter

§ Significant Characteristic

Notes:

Dimensions D and E1 do not include mold flash or protrusions. Mold flash or protrusions shall not exceed .010" (0.254mm) per side.

JEDEC Equivalent: MS-001

Drawing No. C04-007

PIC18F1220/1320

18-Lead Plastic Small Outline (SO) – Wide, 300 mil (SOIC)

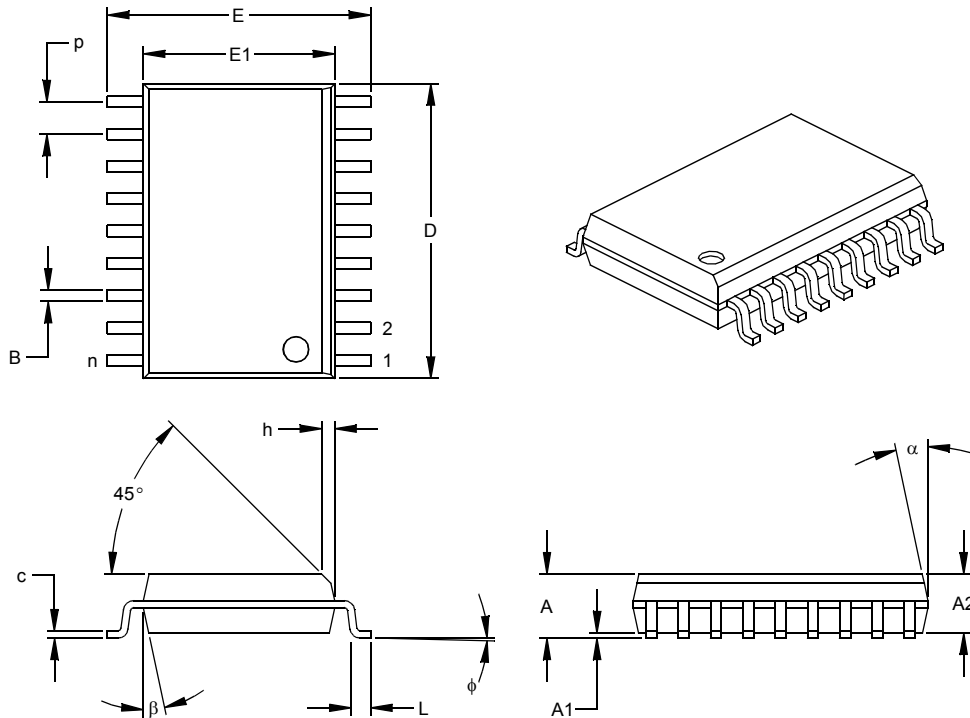

Dimension Limits	Units	INCHES*			MILLIMETERS		
		MIN	NOM	MAX	MIN	NOM	MAX
Number of Pins	n		18			18	
Pitch	p		.050			1.27	
Overall Height	A	.093	.099	.104	2.36	2.50	2.64
Molded Package Thickness	A2	.088	.091	.094	2.24	2.31	2.39
Standoff §	A1	.004	.008	.012	0.10	0.20	0.30
Overall Width	E	.394	.407	.420	10.01	10.34	10.67
Molded Package Width	E1	.291	.295	.299	7.39	7.49	7.59
Overall Length	D	.446	.454	.462	11.33	11.53	11.73
Chamfer Distance	h	.010	.020	.029	0.25	0.50	0.74
Foot Length	L	.016	.033	.050	0.41	0.84	1.27
Foot Angle	φ	0	4	8	0	4	8
Lead Thickness	c	.009	.011	.012	0.23	0.27	0.30
Lead Width	B	.014	.017	.020	0.36	0.42	0.51
Mold Draft Angle Top	α	0	12	15	0	12	15
Mold Draft Angle Bottom	β	0	12	15	0	12	15

* Controlling Parameter
 § Significant Characteristic

Notes:

Dimensions D and E1 do not include mold flash or protrusions. Mold flash or protrusions shall not exceed .010" (0.254mm) per side.

JEDEC Equivalent: MS-013

Drawing No. C04-051

PIC18F1220/1320

20-Lead Plastic Shrink Small Outline (SS) – 209 mil, 5.30 mm (SSOP)

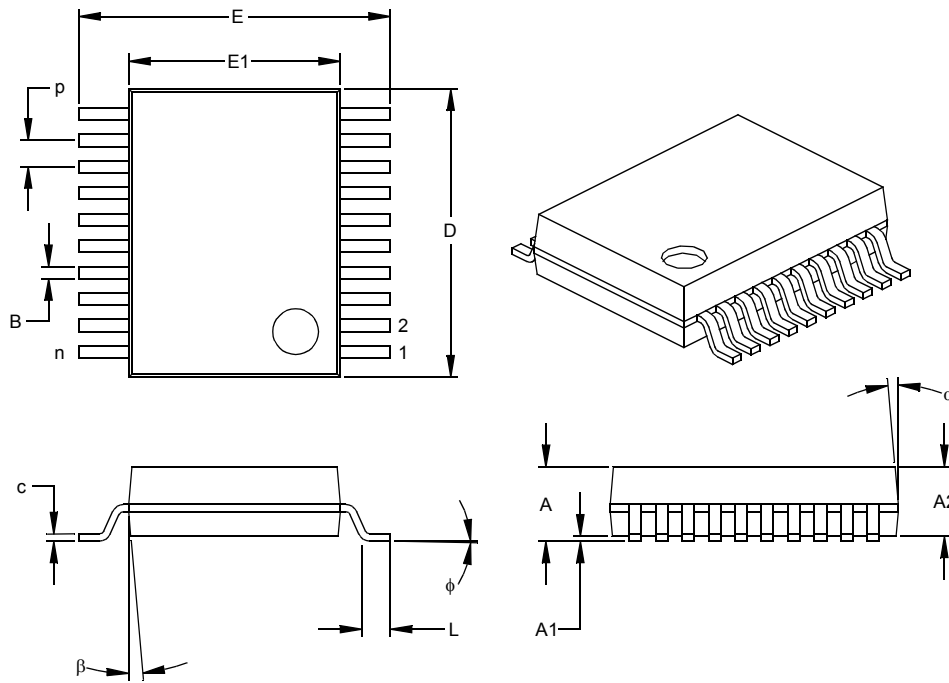

Units		INCHES*			MILLIMETERS		
Dimension Limits		MIN	NOM	MAX	MIN	NOM	MAX
Number of Pins	n		20			20	
Pitch	p		.026			0.65	
Overall Height	A	.068	.073	.078	1.73	1.85	1.98
Molded Package Thickness	A2	.064	.068	.072	1.63	1.73	1.83
Standoff §	A1	.002	.006	.010	0.05	0.15	0.25
Overall Width	E	.299	.309	.322	7.59	7.85	8.18
Molded Package Width	E1	.201	.207	.212	5.11	5.25	5.38
Overall Length	D	.278	.284	.289	7.06	7.20	7.34
Foot Length	L	.022	.030	.037	0.56	0.75	0.94
Lead Thickness	c	.004	.007	.010	0.10	0.18	0.25
Foot Angle	φ	0	4	8	0.00	101.60	203.20
Lead Width	B	.010	.013	.015	0.25	0.32	0.38
Mold Draft Angle Top	α	0	5	10	0	5	10
Mold Draft Angle Bottom	β	0	5	10	0	5	10

* Controlling Parameter

§ Significant Characteristic

Notes:

Dimensions D and E1 do not include mold flash or protrusions. Mold flash or protrusions shall not exceed .010" (0.254mm) per side.

JEDEC Equivalent: MO-150

Drawing No. C04-072

PIC18F1220/1320

28-Lead Plastic Quad Flat No Lead Package (ML) 6x6 mm Body (QFN)

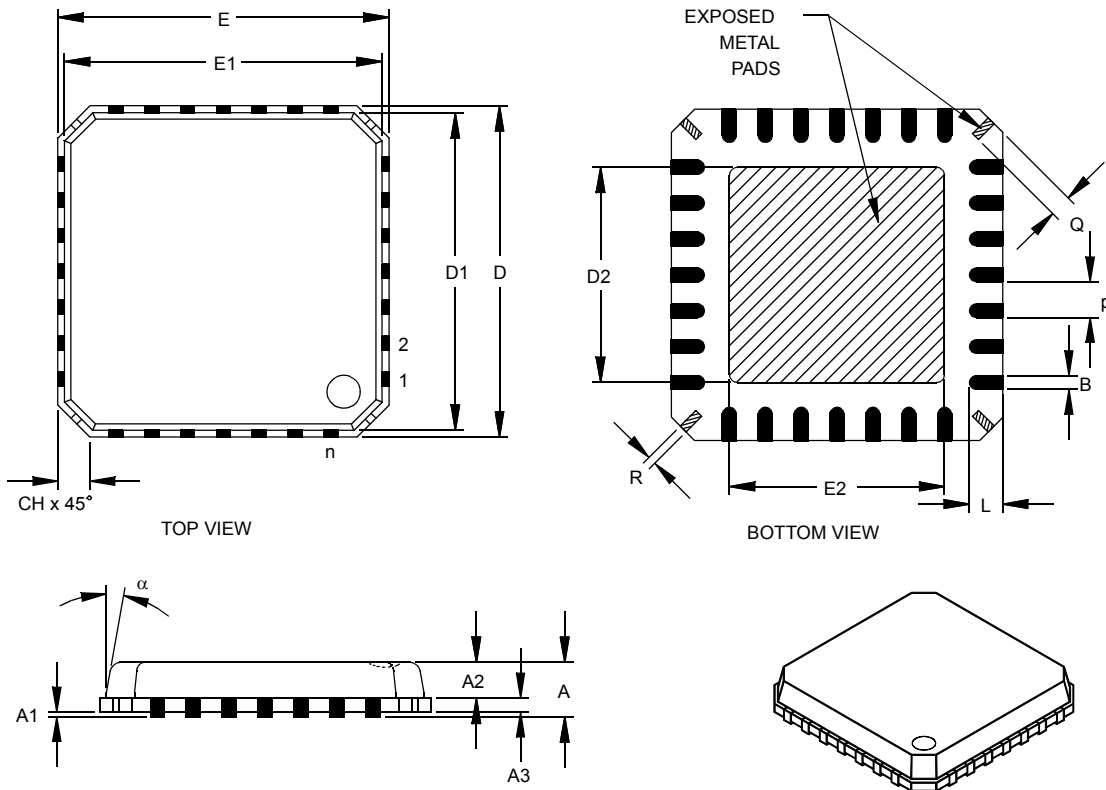

Units		INCHES			MILLIMETERS*		
Dimension Limits		MIN	NOM	MAX	MIN	NOM	MAX
Number of Pins	n		28			28	
Pitch	p	.026 BSC			0.65 BSC		
Overall Height	A		.033	.039		0.85	1.00
Molded Package Thickness	A2		.026	.031		0.65	0.80
Standoff	A1	.000	.0004	.002	0.00	0.01	0.05
Base Thickness	A3		.008 REF.		0.20 REF.		
Overall Width	E		.236 BSC		6.00 BSC		
Molded Package Width	E1		.226 BSC		5.75 BSC		
Exposed Pad Width	E2	.140	.146	.152	3.55	3.70	3.85
Overall Length	D		.236 BSC		6.00 BSC		
Molded Package Length	D1		.226 BSC		5.75 BSC		
Exposed Pad Length	D2	.140	.146	.152	3.55	3.70	3.85
Lead Width	B	.009	.011	.014	0.23	0.28	0.35
Lead Length	L	.020	.024	.030	0.50	0.60	0.75
Tie Bar Width	R	.005	.007	.010	0.13	0.17	0.23
Tie Bar Length	Q	.012	.016	.026	0.30	0.40	0.65
Chamfer	CH	.009	.017	.024	0.24	0.42	0.60
Mold Draft Angle Top	α			12°			12°

*Controlling Parameter

Notes:

Dimensions D and E1 do not include mold flash or protrusions. Mold flash or protrusions shall not exceed .010" (0.254mm) per side.

JEDEC equivalent: M0-220

Drawing No. C04-114

PIC18F1220/1320

28-Lead Plastic Quad Flat No Lead Package (ML) 6x6 mm Body (QFN) Land Pattern and Solder Mask

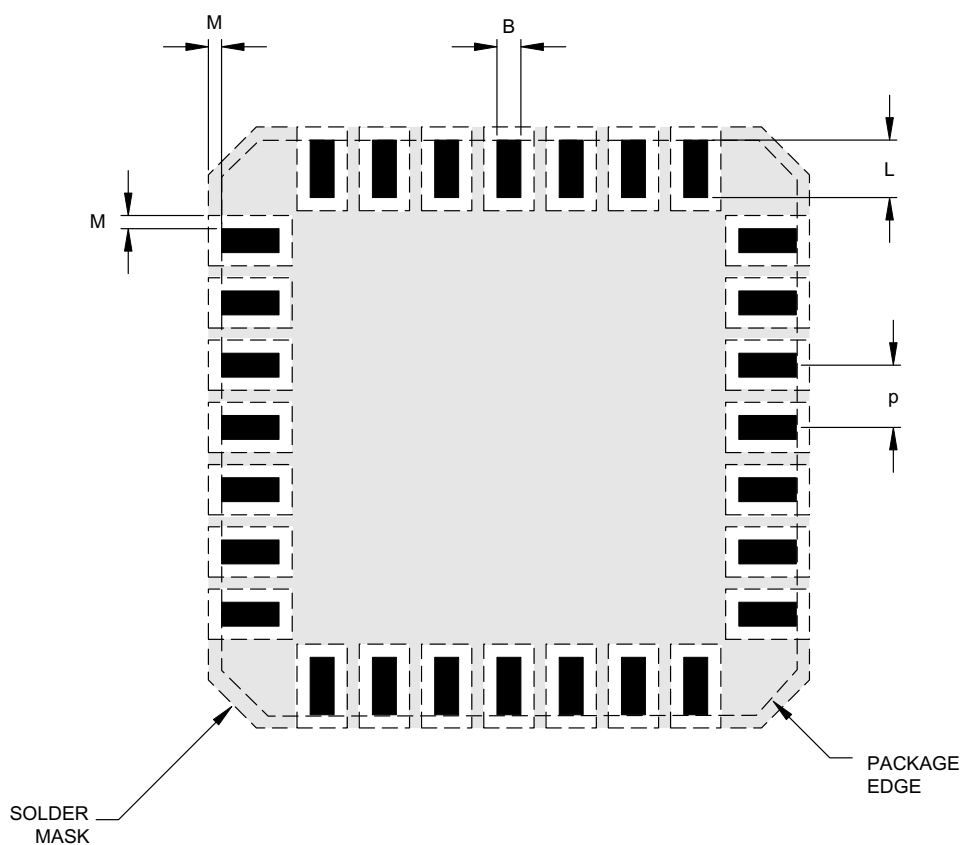

Dimension	Units	INCHES			MILLIMETERS*		
		MIN	NOM	MAX	MIN	NOM	MAX
Pitch	p	.026 BSC			0.65 BSC		
Pad Width	B	.009	.011	.014	0.23	0.28	0.35
Pad Length	L	.020	.024	.030	0.50	0.60	0.75
Pad to Solder Mask	M	.005		.006	0.13		0.15

*Controlling Parameter

Drawing No. C04-2114

APPENDIX A: REVISION HISTORY

Revision A (August 2002)

Original data sheet for PIC18F1220/1320 devices.

Revision B (November 2002)

This revision includes significant changes to Section 2.0, Section 3.0, and Section 19.0, as well as updates to the Electrical Specifications in Section 22.0, and includes minor corrections to the data sheet text.

APPENDIX B: DEVICE DIFFERENCES

The differences between the devices listed in this data sheet are shown in Table B-1.

TABLE B-1: DEVICE DIFFERENCES

Features	PIC18F1220	PIC18F1320
Program Memory (Bytes)	4096	8192
Program Memory (Instructions)	2048	4096
Interrupt Sources	15	15
I/O Ports	Ports A, B	Ports A, B
Enhanced Capture/Compare/PWM Modules	1	1
10-bit Analog-to-Digital Module	7 input channels	7 input channels
Packages	18-pin SDIP 18-pin SOIC 20-pin SSOP 28-pin QFN	18-pin SDIP 18-pin SOIC 20-pin SSOP 28-pin QFN

PIC18F1220/1320

APPENDIX C: CONVERSION CONSIDERATIONS

This appendix discusses the considerations for converting from previous versions of a device to the ones listed in this data sheet. Typically, these changes are due to the differences in the process technology used. An example of this type of conversion is from a PIC16C74A to a PIC16C74B.

Not Applicable

APPENDIX D: MIGRATION FROM BASELINE TO ENHANCED DEVICES

This section discusses how to migrate from a Baseline device (i.e., PIC16C5X) to an Enhanced MCU device (i.e., PIC18FXXX).

The following are the list of modifications over the PIC16C5X microcontroller family:

Not Currently Available

APPENDIX E: MIGRATION FROM MID-RANGE TO ENHANCED DEVICES

A detailed discussion of the differences between the mid-range MCU devices (i.e., PIC16CXXX) and the enhanced devices (i.e., PIC18FXXX) is provided in AN716, "Migrating Designs from PIC16C74A/74B to PIC18F442". The changes discussed, while device specific, are generally applicable to all mid-range to enhanced device migrations.

This Application Note is available as Literature Number DS00716.

APPENDIX F: MIGRATION FROM HIGH-END TO ENHANCED DEVICES

A detailed discussion of the migration pathway and differences between the high-end MCU devices (i.e., PIC17CXXX) and the enhanced devices (i.e., PIC18FXXX) is provided in AN726, "PIC17CXXX to PIC18FXXX Migration".

This Application Note is available as Literature Number DS00726.

PIC18F1220/1320

NOTES:

INDEX

A

A/D	155
A/D Converter Interrupt, Configuring	159
Acquisition Requirements	160
ADCON0 Register	155
ADCON1 Register	155
ADCON2 Register	155
ADRESH Register	155
ADRESH/ADRESL Registers	158
ADRESL Register	155
Analog Port Pins, Configuring	162
Configuring the Module	159
Conversion Clock (TAD)	161
Conversion Requirements	262
Conversion Status (GO/DONE Bit)	158
Conversions	163
Converter Characteristics	261
Operation in Low Power Modes	162
Registers Summary	164
Selecting, Configuring Automatic	
Acquisition Time	161
Special Event Trigger (CCP)	119
Special Event Trigger (CCP1)	164
Use of the CCP1 Trigger	164
VREF+ and VREF- References	160
Absolute Maximum Ratings	237
AC (Timing) Characteristics	251
Conditions	252
Load Conditions for Device Timing	
Specifications	252
Parameter Symbolology	251
Temperature and Voltage Specifications	252
ADCON0 Register	155
GO/DONE Bit	158
ADCON1 Register	155
ADCON2 Register	155
ADDLW	195
ADDWF	195
ADDWFC	196
ADRESH Register	155
ADRESH/ADRESL Registers	158
ADRESL Register	155
Analog-to-Digital Converter. <i>See</i> A/D	
ANDLW	196
ANDWF	197
Assembler	
MPASM Assembler	231
Auto Wake-up on Sync Break Character	147

B

BC	197
BCF	198
Block Diagrams	
A/D	158
Analog Input Model	159
Capture Mode Operation	119
Compare Mode Operation	120
Enhanced PWM	122
Fail-Safe Clock Monitor	182
Generic I/O Port Operation	89
Low Voltage Detect (LVD)	166
Low Voltage Detect (LVD) with External Input	166
On-Chip Reset Circuit	33

PIC18F1220/1320	7
PLL	12
PORTA	
MCLR/RA5 Pin	91
OSC1/CLKI/RA7 Pin	90
OSC2/CLKO/RA6 Pin	90
RA3:RA0 Port Pins	90
RA4/T0CKI Pin	90
PORTB	
RB0/AN4/INT0 Pin	92
RB1/AN5/INT1/TX/CK Pin	93
RB2/P1B/INT2 Pin	94
RB3/CCP1/P1A Pin	95
RB4/AN6/RX/DT/KBI0 Pin	96
RB5/PGM/KBI1 Pin	97
RB6/PGC/T1OSO/T1CKI/P1C/KBI2 Pin	98
RB7/PGD/T1OSI/P1D/KBI3 Pin	99
Reads from FLASH Program Memory	63
System Clock	16
Table Read Operation	59
Table Write Operation	60
Table Writes to FLASH Program Memory	65
Timer0 in 16-bit Mode	102
Timer0 in 8-bit Mode	102
Timer1	106
Timer1 (16-bit Read/Write Mode)	106
Timer2	112
Timer3	114
Timer3 (16-bit R/W Mode)	115
USART Receive	145
USART Transmit	143
WDT	180
BN	198
BNC	199
BNN	199
BNOV	200
BNZ	200
BOR. <i>See</i> Brown-out Reset	
BOV	203
BRA	201
Break Character (12-bit) Transmit and Receive	148
Brown-out Reset (BOR)	34, 171
BSF	201
BTFSC	202
BTFSS	202
BTG	203
BZ	204

C

CALL	204
Capture (CCP Module)	118
CCP Pin Configuration	118
CCPR1H:CCPR1L Registers	118
Software Interrupt	118
Timer1/Timer3 Mode Selection	118
Capture, Compare, Timer1 and Timer3	
Associated Registers	120
Capture/Compare/PWM (CCP)	
Capture Mode. <i>See</i> Capture	
CCP1	118
CCPR1H Register	118
CCPR1L Register	118
Compare Mode. <i>See</i> Compare	
Timer Resources	118

PIC18F1220/1320

Clock Sources	15	DC Characteristics	247
Selection Using OSCCON Register	16	Power-Down and Supply Current	240
Clocking Scheme	47	Supply Voltage	239
CLRF	205	DCFSNZ	209
CLRWDT	205	DECf	208
Code Examples		DECFSZ	209
16 x 16 Signed Multiply Routine	74	Details on Individual Family Members	6
16 x 16 Unsigned Multiply Routine	74	Development Support	231
8 x 8 Signed Multiply Routine	73	Device Differences	273
8 x 8 Unsigned Multiply Routine	73	Direct Addressing	56
Changing Between Capture Prescalers	119	E	
Computed GOTO Using an Offset Value	49	Effects of Power Managed Modes on	
Data EEPROM Read	71	Various Clock Sources	18
Data EEPROM Refresh Routine	72	Electrical Characteristics	237
Data EEPROM Write	71	Enhanced Capture/Compare/PWM (ECCP)	117
Erasing a FLASH Program Memory Row	64	Outputs	118
Fast Register Stack	46	PWM Mode. See PWM (ECCP Module)	
How to Clear RAM (Bank1) Using		Enhanced PWM Mode. See PWM (ECCP Module)	121
Indirect Addressing	55	Enhanced Universal Synchronous Asynchronous	
Implementing a Real-Time Clock Using a		Receiver Transmitter (USART)	133
Timer1 Interrupt Service	109	Equations	
Initializing PORTA	89	16 x 16 Signed Multiplication Algorithm	74
Initializing PORTB	92	16 x 16 Unsigned Multiplication Algorithm	74
Reading a FLASH Program Memory Word	63	A/D Minimum Charging Time	160
Saving STATUS, WREG and BSR Registers		Acquisition Time	160
in RAM	87	Errata	4
Writing to FLASH Program Memory	66–67	F	
Code Protection	171	Fail-Safe Clock Monitor	171
COMF	206	Exiting Operation	183
Compare (CCP Module)	119	Interrupts in Power Managed Modes	183
CCP Pin Configuration	119	POR or Wake from SLEEP	184
CCPR1 Register	119	WDT During Oscillator Failure	182
Software Interrupt	119	Fail-Safe Clock Monitor (FSCM)	182
Special Event Trigger	116, 119	Fast Register Stack	46
Timer1/Timer3 Mode Selection	119	Firmware Instructions	189
Compare (CCP1 Module)		FLASH Program Memory	59
Special Event Trigger	164	Associated Registers	67
Computed GOTO	49	Control Registers	60
Configuration Bits	171	Erase Sequence	64
Context Saving During Interrupts	87	Erasing	64
Conversion Considerations	274	Operation During Code Protect	67
CPFSEQ	206	Reading	63
CPFSGT	207	TABLAT Register	62
CPFSLT	207	Table Pointer	62
D		Boundaries Based on Operation	62
Data EEPROM Memory	69	Table Pointer Boundaries	62
Associated Registers	72	Table Reads and Table Writes	59
EEADR Register	69	Write Sequence	65
EECON1 Register	69	Writing to	65
EECON2 Register	69	Unexpected Termination	67
Operation During Code Protect	72	Write Verify	67
Protection Against Spurious Write	71	G	
Reading	71	GOTO	210
Using	72	H	
Write Verify	71	Hardware Multiplier	73
Writing	71	Introduction	73
Data Memory	49	Operation	73
General Purpose Registers	49	Performance Comparison	73
Map for PIC18F1220/1320 Devices	50		
Special Function Registers	51		
DAW	208		
DC and AC Characteristics			
Graphs and Tables (Preliminary)	263		

PIC18F1220/1320

I

I/O Ports	89	POP	218
ICEPIC In-Circuit Emulator	232	PUSH	218
ID Locations	171, 188	RCALL	219
INCF	210	RESET	219
INCFSZ	211	RETFIE	220
In-Circuit Debugger	188	RETLW	220
In-Circuit Serial Programming (ICSP)	171, 188	RETURN	221
Indirect Addressing	56	RLCF	221
INDF and FSR Registers	55	RLNCF	222
Operation	55	RRCF	222
Indirect Addressing Operation	56	RRNCF	223
Indirect File Operand	49	SETF	223
INFSNZ	211	SLEEP	224
Initialization Conditions for All Registers	36	SUBFWB	224
Instruction Cycle	47	SUBLW	225
Instruction Flow/Pipelining	47	SUBWF	225
Instruction Format	191	SUBWFB	226
Instruction Set	189	SWAPF	226
ADDLW	195	TBLRD	227
ADDWF	195	TBLWT	228
ADDWFC	196	TSTFSZ	229
ANDLW	196	XORLW	229
ANDWF	197	XORWF	230
BC	197	Summary Table	192
BCF	198	INTCON Register	
BN	198	RBIF Bit	92
BNC	199	INTCON Registers	77
BNN	199	Internal Oscillator Block	14
BNOV	200	Adjustment	14
BNZ	200	INTIO Modes	14
BOV	203	INTRC Output Frequency	14
BRA	201	OSCTUNE Register	14
BSF	201	Internal RC Oscillator	
BTFSC	202	Use with WDT	180
BTFSS	202	Interrupt Sources	171
BTG	203	A/D Conversion Complete	159
BZ	204	Capture Complete (CCP)	118
CALL	204	Compare Complete (CCP)	119
CLRF	205	Interrupt-on-Change (RB7:RB4)	92
CLRWDT	205	INTn Pin	87
COMF	206	PORTB, Interrupt-on-Change	87
CPFSEQ	206	TMR0	87
CPFSGT	207	TMR0 Overflow	103
CPFSLT	207	TMR1 Overflow	105
DAW	208	TMR2 to PR2 Match	112
DCFSNZ	209	TMR2 to PR2 Match (PWM)	111, 121
DECF	208	TMR3 Overflow	113, 116
DECFSZ	209	Interrupts	75
GOTO	210	Enable Bits	
INCF	210	(CCP1IE Bit)	118
INCFSZ	211	Flag Bits	
INFSNZ	211	CCP1 Flag (CCP1IF Bit)	118
IORLW	212	CCP1IF Flag (CCP1IF Bit)	119
IORWF	212	Interrupt-on-Change (RB7:RB4) Flag	
LFSR	213	(RBIF Bit)	92
MOVF	213	Logic	76
MOVFF	214	INTOSC Frequency Drift	30
MOVLB	214	IORLW	212
MOVLW	215	IORWF	212
MOVWF	215	IPR Registers	84
MULLW	216	K	
MULWF	216	KEELOQ Evaluation and Programming Tools	234
NEGF	217		
NOP	217		

PIC18F1220/1320

L

LFSR	213
Low Voltage Detect	165
Characteristics	250
Effects of a RESET	169
Operation	168
Current Consumption	169
Reference Voltage Set Point	169
Operation During SLEEP	169
LVD. See Low Voltage Detect.	165

M

Memory Organization	43
Data Memory	49
Program Memory	43
Memory Programming Requirements	249
Migration from Baseline to Enhanced Devices	274
Migration from High-End to Enhanced Devices	275
Migration from Mid-Range to Enhanced Devices	275
MOVF	213
MOVFF	214
MOVLB	214
MOVLW	215
MOVWF	215
MPLAB C17 and MPLAB C18 C Compilers	231
MPLAB ICD In-Circuit Debugger	233
MPLAB ICE High Performance Universal In-Circuit Emulator with MPLAB IDE	232
MPLAB Integrated Development Environment Software	231
MPLINK Object Linker/MPLIB Object Librarian	232
MULLW	216
MULWF	216

N

NEGF	217
New Core Features	
Multiple Oscillator Options and Features	5
Nanowatt Technology	5
NOP	217

O

OPCODE Field Descriptions	190
OPTION_REG Register	
PSA Bit	103
T0CS Bit	103
T0PS2:T0PS0 Bits	103
T0SE Bit	103
Oscillator Configuration	11
Crystal/Ceramic Resonator	11
EC	11
ECIO	11
External Clock Input	13
HS	11
HSPLL	11, 12
INTIO1	11
INTIO2	11
LP	11
RC	11, 13
RCIO	11
XT	11
Oscillator Selection	171
Oscillator Start-up Timer (OST)	18, 34, 171

Oscillator Switching	15
Oscillator Transitions	18
Oscillator, Timer1	105, 116
Oscillator, Timer3	113
Other Special Features	5

P

Packaging	267
Details	268
Marking Information	267
PICDEM 1 Low Cost PICmicro Demonstration Board	233
PICDEM 17 Demonstration Board	234
PICDEM 2 Low Cost PIC16CXX Demonstration Board	233
PICDEM 3 Low Cost PIC16CXXX Demonstration Board	234
PICSTART Plus Entry Level Development Programmer	233
PIE Registers	82
Pin Functions	
MCLR/VPP/RA5	8
OSC1/CLKI/RA7	8
OSC2/CLKO/RA6	8
RA0/AN0	8
RA1/AN1/LVDIN	8
RA2/AN2/REF-	8
RA3/AN3/REF+	8
RA4/T0CKI	8
RB0/AN4/INT0	9
RB1/AN5/TX/CK/INT1	9
RB2/P1B/INT2	9
RB3/CCP1/P1A	9
RB4/AN6/RX/DT/KBI0	9
RB5/PGM/KBI1	9
RB6/PGC/T1OSO/T1CKI/P1C/KBI2	9
RB7/PGD/T1OSI/P1D/KBI3	9
VDD	9
Vss	9
Pinout I/O Descriptions PIC18F1220/1320	8
PIR Registers	80
PLL Lock Time-out	34
Pointer, FSR	55
POP	218
POR. See Power-on Reset	
PORTA	
Associated Registers	91
Functions	91
LATA Register	89
PORTA Register	89
TRISA Register	89
PORTB	
Associated Registers	100
Functions	100
LATB Register	92
PORTB Register	92
RB7:RB4 Interrupt-on-Change Flag (RBIF Bit)	92
TRISB Register	92
Postscaler	
Timer2	111
WDT	
Assignment (PSA Bit)	103
Rate Select (T0PS2:T0PS0 Bits)	103

Power Managed Modes	19
Entering	20
IDLE Modes	21
RUN Modes	26
Selecting	19
SLEEP Mode	21
Summary (table)	19
Wake from	28
Power-on Reset (POR)	34, 171
Power-up Delays	18
Power-up Timer (PWRT)	18, 34, 171
Prescaler	
Capture	119
Timer0	103
Assignment (PSA Bit)	103
Rate Select (T0PS2:T0PS0 Bits)	103
Timer2	121
PRO MATE II Universal Device Programmer	233
Product Identification System	287
Program Counter	
PCL Register	46
PCLATH Register	46
PCLATU Register	46
Program Memory	
Instructions in	48
Interrupt Vector	43
Map and Stack for PIC18F1220	43
Map and Stack for PIC18F1320	43
RESET Vector	43
Program Verification and Code Protection	185
Associated Registers	185
Configuration Register	188
Data EEPROM	188
Program Memory	186
Programming, Device Instructions	189
PUSH	218
PUSH and POP Instructions	45
PWM (CCP Module)	
CCPR1H:CCPR1L Registers	121
Duty Cycle	121
Example Frequencies/Resolutions	121
Period	121
TMR2 to PR2 Match	111, 121
PWM (ECCP Module)	121
Associated Registers	132
Direction Change in Full-Bridge	
Output Mode	126
Effects of a RESET	131
Enhanced PWM Auto Shutdown	128
Full-Bridge Application Example	126
Full-Bridge PWM Output Diagram	125
Half-Bridge Output Diagram	124
Half-Bridge Output Mode	
Applications Example	124
Operation in Low Power Modes	131
Output Configurations	121
Output Relationships (Active High)	122
Output Relationships (Active Low)	123
Programmable Deadband Delay	128
PWM Direction Change at Near 100%	
Duty Cycle Diagram	127
PWM Direction Change Diagram	127
Setup for PWM Operation	131
Start-up Considerations	130

Q

Q Clock	121
---------------	-----

R

RAM. See Data Memory	
RCALL	219
RCIO Oscillator	13
RCON Register	
Bit Status During Initialization	35
RCSTA Register	
SPEN Bit	133
Register File	49
Register File Summary	52
Registers	
ADCON0 (A/D Control 0)	155
ADCON1 (A/D Control 1)	156
ADCON2 (A/D Control 2)	157
BAUDCTL (Baud Rate Control)	136
CCP1CON (Enhanced CCP1 Control)	117
CONFIG1H (Configuration 1 High)	172
CONFIG2H (Configuration 2 High)	174
CONFIG2L (Configuration 2 Low)	173
CONFIG3H (Configuration 3 High)	175
CONFIG4L (Configuration 4 Low)	175
CONFIG5H (Configuration 5 High)	176
CONFIG5L (Configuration 5 Low)	176
CONFIG6H (Configuration 6 High)	177
CONFIG6L (Configuration 6 Low)	177
CONFIG7H (Configuration 7 High)	178
CONFIG7L (Configuration 7 Low)	178
DEVID1 (Device ID 1)	179
DEVID2 (Device ID 2)	179
ECCPAS (ECCP Auto Shutdown Control)	129
EECON1 (Data EEPROM Control 1)	61, 70
INTCON (Interrupt Control)	77
INTCON2 (Interrupt Control 2)	78
INTCON3 (Interrupt Control 3)	79
IPR1 (Peripheral Interrupt Priority 1)	84
IPR2 (Peripheral Interrupt Priority 2)	85
LVDCON (LVD Control)	167
OSCCON (Oscillator Control)	17
OSCTUNE (Oscillator Tuning)	15
PIE1 (Peripheral Interrupt Enable 1)	82
PIE2 (Peripheral Interrupt Enable 2)	83
PIR1 (Peripheral Interrupt Request (Flag) 1)	80
PIR2 (Peripheral Interrupt Request (Flag) 2)	81
PWM1CON (PWM Configuration)	128
RCON (Register Control)	86
RCON (RESET Control)	58
RCSTA (Receive Status and Control)	135
STATUS	57
STKPTR (Stack Pointer)	45
T0CON (Timer0 Control)	101
T1CON (Timer 1 Control)	105
T2CON (Timer 2 Control)	111
T3CON (Timer3 Control)	113
TXSTA (Transmit Status and Control)	134
WDTCON (Watchdog Timer Control)	180
RESET	33, 171, 219
RETFIE	220
RETLW	220
RETURN	221

PIC18F1220/1320

Return Address Stack 44	Timer2 111
and Associated Registers 44	Associated Registers 112
Return Stack Pointer (STKPTR) 44	Operation 111
Revision History 273	Postscaler. <i>See</i> Postscaler, Timer2
RLCF 221	PR2 Register 111, 121
RLNCF 222	Prescaler. <i>See</i> Prescaler, Timer2
RRCF 222	SSP Clock Shift 112
RRNCF 223	TMR2 Register 111
S	TMR2 to PR2 Match Interrupt 111, 112, 121
SETF 223	Timer3 113
SLEEP 224	Associated Registers 116
OSC1 and OSC2 Pin States 18	Operation 114
Software Simulator (MPLAB SIM) 232	Oscillator 113, 116
Special Event Trigger. <i>See</i> Compare	Overflow Interrupt 113, 116
Special Features of the CPU 171	Special Event Trigger (CCP) 116
Configuration Registers 172–178	TMR3H Register 113
Special Function Registers 51	TMR3L Register 113
Map 51	Timing Diagrams
SSP	A/D Conversion 262
TMR2 Output for Clock Shift 112	Asynchronous Reception 146
Stack Full/Underflow Resets 45	Asynchronous Transmission 143
SUBFWB 224	Asynchronous Transmission (Back to Back) 143
SUBLW 225	Auto Wake-up Bit (WUE) During Normal Operation 147
SUBWF 225	Auto Wake-up Bit (WUE) During SLEEP 147
SUBWFB 226	Brown-out Reset (BOR) 256
SWAPF 226	Capture/Compare/PWM (All CCP Modules) 259
T	CLKO and I/O 255
TABLAT Register 62	Clock/Instruction Cycle 47
Table Pointer Operations (table) 62	External Clock (All Modes except PLL) 253
TBLPTR Register 62	Fail-Safe Clock Monitor 183
TBLRD 227	Low Voltage Detect 168
TBLWT 228	PWM Auto Shutdown (PRSEN = 0,
Time-out Sequence 34	Auto Restart Disabled) 130
Timer0 101	PWM Auto Shutdown (PRSEN = 1,
16-bit Mode Timer Reads and Writes 103	Auto Restart Enabled) 130
Associated Registers 103	RESET, Watchdog Timer (WDT),
Clock Source Edge Select (T0SE Bit) 103	Oscillator Start-up Timer (OST) and
Clock Source Select (T0CS Bit) 103	Power-up Timer (PWRT) 256
Operation 103	Send Break Character Sequence 148
Overflow Interrupt 103	Slow Rise Time ($\overline{\text{MCLR}}$ Tied to VDD,
Prescaler. <i>See</i> Prescaler, Timer0	VDD Rise > TPWRT) 41
Switching Prescaler Assignment 103	Synchronous Reception (Master Mode, SREN) 151
Timer1 105	Synchronous Transmission 149
16-bit Read/Write Mode 108	Synchronous Transmission (Through TXEN) 150
Associated Registers 109	Time-out Sequence on POR w/ PLL Enabled
Interrupt 107	($\overline{\text{MCLR}}$ Tied to VDD) 41
Operation 106	Time-out Sequence on Power-up
Oscillator 105, 107	($\overline{\text{MCLR}}$ Not Tied to VDD) Case 1 40
Oscillator Layout Considerations 107	Time-out Sequence on Power-up
Overflow Interrupt 105	($\overline{\text{MCLR}}$ Not Tied to VDD) Case 2 40
Resetting, Using a Special Event	Time-out Sequence on Power-up
Trigger Output (CCP) 108	($\overline{\text{MCLR}}$ Tied to VDD, VDD Rise TPWRT) 40
Special Event Trigger (CCP) 119	Timer0 and Timer1 External Clock 257
TMR1H Register 105	Transition for Entry to SEC_IDLE Mode 24
TMR1L Register 105	Transition for Entry to SEC_RUN Mode 26
Use as a Real-Time Clock 108	Transition for Entry to SLEEP Mode 22
	Transition for Two-Speed Start-up
	(INTOSC to HSPLL) 181
	Transition for Wake from RC_RUN Mode
	(RC_RUN to PRI_RUN) 25

Transition for Wake from SEC_RUN Mode (Secondary Clock to HSPLL)	24
Transition for Wake from SLEEP (HSPLL)	22
Transition Timing For Wake from PRI_IDLE Mode	23
Transition Timing to PRI_IDLE Mode	23
Transition to RC_IDLE Mode	25
Transition to RC_RUN Mode	27
USART Synchronous Receive (Master/Slave)	260
USART Synchronous Transmission (Master/Slave)	260
Timing Diagrams and Specifications	253
Capture/Compare/PWM Requirements (All CCP Modules)	259
CLKO and I/O Requirements	255
DC Characteristics - Internal RC Accuracy	254
External Clock Requirements	253
PLL Clock (V _{DD} = 4.2 to 5.5V)	254
RESET, Watchdog Timer, Oscillator Start-up Timer, Power-up Timer and Brown-out Reset Requirements	257
Timer0 and Timer1 External Clock Requirements	258
USART Synchronous Receive Requirements	260
USART Synchronous Transmission Requirements	260
Top-of-Stack Access	44
TSTFSZ	229
Two-Speed Start-up	171, 181
Two-Word Instructions	48
Example Cases	48
TXSTA Register BRGH Bit	137

U

USART

Asynchronous Mode	142
12-bit Break Transmit and Receive	148
Associated Registers, Receive	146
Associated Registers, Transmit	144
Auto Wake-up on Sync Break	147
Receiver	145
Setting up 9-bit Mode with Address Detect	145
Transmitter	142
Baud Rate Generator (BRG)	137
Associated Registers	138
Auto Baud Rate Detect	141
Baud Rate Error, Calculating	138
Baud Rates, Asynchronous Modes	138
High Baud Rate Select (BRGH Bit)	137
Power Managed Mode Operation	137
Sampling	137
Serial Port Enable (SPEN Bit)	133
Synchronous Master Mode	149
Associated Registers, Reception	152
Associated Registers, Transmit	150
Reception	151
Transmission	149
Synchronous Slave Mode	153
Associated Registers, Receive	154
Associated Registers, Transmit	153
Reception	154
Transmission	153

W

Watchdog Timer (WDT)	171, 180
Associated Registers	181
Control Register	180
During Oscillator Failure	182
Programming Considerations	180
WWW, On-Line Support	4

X

XORLW	229
XORWF	230

PIC18F1220/1320

NOTES:

ON-LINE SUPPORT

Microchip provides on-line support on the Microchip World Wide Web site.

The web site is used by Microchip as a means to make files and information easily available to customers. To view the site, the user must have access to the Internet and a web browser, such as Netscape® or Microsoft® Internet Explorer. Files are also available for FTP download from our FTP site.

Connecting to the Microchip Internet Web Site

The Microchip web site is available at the following URL:

www.microchip.com

The file transfer site is available by using an FTP service to connect to:

<ftp://ftp.microchip.com>

The web site and file transfer site provide a variety of services. Users may download files for the latest Development Tools, Data Sheets, Application Notes, User's Guides, Articles and Sample Programs. A variety of Microchip specific business information is also available, including listings of Microchip sales offices, distributors and factory representatives. Other data available for consideration is:

- Latest Microchip Press Releases
- Technical Support Section with Frequently Asked Questions
- Design Tips
- Device Errata
- Job Postings
- Microchip Consultant Program Member Listing
- Links to other useful web sites related to Microchip Products
- Conferences for products, Development Systems, technical information and more
- Listing of seminars and events

SYSTEMS INFORMATION AND UPGRADE HOT LINE

The Systems Information and Upgrade Line provides system users a listing of the latest versions of all of Microchip's development systems software products. Plus, this line provides information on how customers can receive the most current upgrade kits. The Hot Line Numbers are:

1-800-755-2345 for U.S. and most of Canada, and

1-480-792-7302 for the rest of the world.

092002

PIC18F1220/1320

READER RESPONSE

It is our intention to provide you with the best documentation possible to ensure successful use of your Microchip product. If you wish to provide your comments on organization, clarity, subject matter, and ways in which our documentation can better serve you, please FAX your comments to the Technical Publications Manager at (480) 792-4150.

Please list the following information, and use this outline to provide us with your comments about this document.

To: Technical Publications Manager
RE: Reader Response
From: Name _____
Company _____
Address _____
City / State / ZIP / Country _____
Telephone: (_____) _____ - _____ FAX: (_____) _____ - _____

Application (optional):

Would you like a reply? ___Y ___N

Device: PIC18F1220/1320 Literature Number: DS39605B

Questions:

1. What are the best features of this document?

2. How does this document meet your hardware and software development needs?

3. Do you find the organization of this document easy to follow? If not, why?

4. What additions to the document do you think would enhance the structure and subject?

5. What deletions from the document could be made without affecting the overall usefulness?

6. Is there any incorrect or misleading information (what and where)?

7. How would you improve this document?

PIC18F1220/1320 PRODUCT IDENTIFICATION SYSTEM

To order or obtain information, e.g., on pricing or delivery, refer to the factory or the listed sales office.

<u>PART NO.</u>	-	<u>X</u>	<u>/XX</u>	<u>XXX</u>
Device		Temperature Range	Package	Pattern
Device	PIC18F1220/1320 ⁽¹⁾ , PIC18F1220/1320 ⁽²⁾ ; VDD range 4.2V to 5.5V			
	PIC18LF1220/1320 ⁽¹⁾ , PIC18LF1220/1320 ⁽²⁾ ; VDD range 2.5V to 5.5V			
Temperature Range	I = -40°C to +85°C (Industrial)			
Package	SO = SOIC P = PDIP		SS = SSOP ML = QFN	
Pattern	QTP, SQTP, Code or Special Requirements (blank otherwise)			

Examples:

a) PIC18LF1320 - I/P 301 = Industrial temp., PDIP package, Extended VDD limits, QTP pattern #301.

b) PIC18LF1220 - I/SO = Industrial temp., SOIC package, Extended VDD limits.

Note 1: F = Standard Voltage range
LF = Wide Voltage Range

2: T = in tape and reel - SOIC package only

Sales and Support

Data Sheets

Products supported by a preliminary Data Sheet may have an errata sheet describing minor operational differences and recommended workarounds. To determine if an errata sheet exists for a particular device, please contact one of the following:

1. Your local Microchip sales office
2. The Microchip Corporate Literature Center U.S. FAX: (480) 792-7277
3. The Microchip Worldwide Site (www.microchip.com)

Please specify which device, revision of silicon and Data Sheet (include Literature #) you are using.

New Customer Notification System

Register on our web site (www.microchip.com/cn) to receive the most current information on our products.



WORLDWIDE SALES AND SERVICE

AMERICAS

Corporate Office

2355 West Chandler Blvd.
Chandler, AZ 85224-6199
Tel: 480-792-7200 Fax: 480-792-7277
Technical Support: 480-792-7627
Web Address: <http://www.microchip.com>

Rocky Mountain

2355 West Chandler Blvd.
Chandler, AZ 85224-6199
Tel: 480-792-7966 Fax: 480-792-4338

Atlanta

500 Sugar Mill Road, Suite 200B
Atlanta, GA 30350
Tel: 770-640-0034 Fax: 770-640-0307

Boston

2 Lan Drive, Suite 120
Westford, MA 01886
Tel: 978-692-3848 Fax: 978-692-3821

Chicago

333 Pierce Road, Suite 180
Itasca, IL 60143
Tel: 630-285-0071 Fax: 630-285-0075

Dallas

4570 Westgrove Drive, Suite 160
Addison, TX 75001
Tel: 972-818-7423 Fax: 972-818-2924

Detroit

Tri-Atria Office Building
32255 Northwestern Highway, Suite 190
Farmington Hills, MI 48334
Tel: 248-538-2250 Fax: 248-538-2260

Kokomo

2767 S. Albright Road
Kokomo, Indiana 46902
Tel: 765-864-8360 Fax: 765-864-8387

Los Angeles

18201 Von Karman, Suite 1090
Irvine, CA 92612
Tel: 949-263-1888 Fax: 949-263-1338

San Jose

Microchip Technology Inc.
2107 North First Street, Suite 590
San Jose, CA 95131
Tel: 408-436-7950 Fax: 408-436-7955

Toronto

6285 Northam Drive, Suite 108
Mississauga, Ontario L4V 1X5, Canada
Tel: 905-673-0699 Fax: 905-673-6509

ASIA/PACIFIC

Australia

Microchip Technology Australia Pty Ltd
Suite 22, 41 Rawson Street
Epping 2121, NSW
Australia
Tel: 61-2-9868-6733 Fax: 61-2-9868-6755

China - Beijing

Microchip Technology Consulting (Shanghai)
Co., Ltd., Beijing Liaison Office
Unit 915
Bei Hai Wan Tai Bldg.
No. 6 Chaoyangmen Beidajie
Beijing, 100027, No. China
Tel: 86-10-85282100 Fax: 86-10-85282104

China - Chengdu

Microchip Technology Consulting (Shanghai)
Co., Ltd., Chengdu Liaison Office
Rm. 2401, 24th Floor,
Ming Xing Financial Tower
No. 88 TIDU Street
Chengdu 610016, China
Tel: 86-28-86766200 Fax: 86-28-86766599

China - Fuzhou

Microchip Technology Consulting (Shanghai)
Co., Ltd., Fuzhou Liaison Office
Unit 28F, World Trade Plaza
No. 71 Wusi Road
Fuzhou 350001, China
Tel: 86-591-7503506 Fax: 86-591-7503521

China - Shanghai

Microchip Technology Consulting (Shanghai)
Co., Ltd.
Room 701, Bldg. B
Far East International Plaza
No. 317 Xian Xia Road
Shanghai, 200051
Tel: 86-21-6275-5700 Fax: 86-21-6275-5060

China - Shenzhen

Microchip Technology Consulting (Shanghai)
Co., Ltd., Shenzhen Liaison Office
Rm. 1315, 13/F, Shenzhen Kerry Centre,
Renminnan Lu
Shenzhen 518001, China
Tel: 86-755-82350361 Fax: 86-755-82366086

China - Hong Kong SAR

Microchip Technology Hongkong Ltd.
Unit 901-6, Tower 2, Metroplaza
223 Hing Fong Road
Kwai Fong, N.T., Hong Kong
Tel: 852-2401-1200 Fax: 852-2401-3431

India

Microchip Technology Inc.
India Liaison Office
Divyasree Chambers
1 Floor, Wing A (A3/A4)
No. 11, O'Shaughnessy Road
Bangalore, 560 025, India
Tel: 91-80-2290061 Fax: 91-80-2290062

Japan

Microchip Technology Japan K.K.
Benex S-1 6F
3-18-20, Shinyokohama
Kohoku-Ku, Yokohama-shi
Kanagawa, 222-0033, Japan
Tel: 81-45-471-6166 Fax: 81-45-471-6122

Korea

Microchip Technology Korea
168-1, Youngbo Bldg. 3 Floor
Samsung-Dong, Kangnam-Ku
Seoul, Korea 135-882
Tel: 82-2-554-7200 Fax: 82-2-558-5934

Singapore

Microchip Technology Singapore Pte Ltd.
200 Middle Road
#07-02 Prime Centre
Singapore, 188980
Tel: 65-6334-8870 Fax: 65-6334-8850

Taiwan

Microchip Technology (Barbados) Inc.,
Taiwan Branch
11F-3, No. 207
Tung Hua North Road
Taipei, 105, Taiwan
Tel: 886-2-2717-7175 Fax: 886-2-2545-0139

EUROPE

Austria

Microchip Technology Austria GmbH
Durisolstrasse 2
A-4600 Wels
Austria
Tel: 43-7242-2244-399
Fax: 43-7242-2244-393

Denmark

Microchip Technology Nordic ApS
Regus Business Centre
Lautrup hoj 1-3
Ballerup DK-2750 Denmark
Tel: 45 4420 9895 Fax: 45 4420 9910

France

Microchip Technology SARL
Parc d'Activite du Moulin de Massy
43 Rue du Saule Trapu
Batiment A - 1er Etage
91300 Massy, France
Tel: 33-1-69-53-63-20 Fax: 33-1-69-30-90-79

Germany

Microchip Technology GmbH
Steinheilstrasse 10
D-85737 Ismaning, Germany
Tel: 49-89-627-144 0 Fax: 49-89-627-144-44

Italy

Microchip Technology SRL
Centro Direzionale Colleoni
Palazzo Taurus 1 V. Le Colleoni 1
20041 Agrate Brianza
Milan, Italy
Tel: 39-039-65791-1 Fax: 39-039-6899883

United Kingdom

Microchip Ltd.
505 Eskdale Road
Winnersh Triangle
Wokingham
Berkshire, England RG41 5TU
Tel: 44 118 921 5869 Fax: 44-118 921-5820

10/18/02